

SINCE 1889



LAB FREEZER / REFRIGERATOR COMBINATION RFC2001

MODEL

INSTRUCTION MANUAL

- FIRST EDITION -

- Thank you for purchasing RFC2001 Laboratory Freezer / Refrigerator Combination of Yamato Scientific.
 - To use this unit properly, read this "Instruction Manual" thoroughly before using this unit. Keep this instruction manual around this unit for referring at any time.
- !** **WARNING:** Carefully read and thoroughly understand the important warning items described in this manual before using this unit.

**Yamato Scientific America Inc.
Santa Clara, CA**

INSTALLATION AND OPERATING INSTRUCTIONS

1. INSTALLATION

a. Receiving Inspection:

Upon receipt, check all packages for accessories or optional components, including legs, caster, shelves or pan slides. Keys for door locks are attached to one of the doors. (When lock is installed.)

b. Legs & Casters:

Each cabinet is provided with four threaded legs or casters shipped separately. Legs and casters screw directly into the weld nut provided in each corner of the base.

c. Leveling: To provide adequate drainage and proper door alignment and operation, it is necessary that the cabinet be level. Level cabinet from front to rear and from side to side by adjusting leg inserts. This should be done after cabinet has been set in its final operating position.

d. Shelves: Included are two epoxy coated wire shelves per door opening. Shelf spacing is adjustable with enclosed shelf supports to suit requirements. (Figure 1.)

e. Locating Cooler:

For proper operation of the cooler, provide at least three inches of space between the rear of the cabinet and any adjacent wall or fixture and minimum 12 inches of clearance between the top of the cooler and the ceiling or any other fixture.

2. OPERATION

a. Electrical Supply & Connections: A wiring diagram is provided with this manual. It is important that the cabinet be connected into a separate single circuit. Before connecting cabinet, check line voltage to assure it is compatible with the voltage specified on the data plate. Low line voltage is often the cause of service complaints. Wiring should be sufficient to carry the electrical load and to meet local codes. A qualified electrician should make the necessary electrical connections. Be sure cabinet is properly grounded. Check supply voltage after unit has started to be sure circuit is not overloaded.

Use of Extension Cords:

NEVER USE EXTENTION CORDS. YSA WILL NOT WARRANTY ANY FREEZERS AND REFRIGERATORS THAT HAVE BEEN CONNECTED TO AN EXTENSION CORD.

b. Initial Start-Up: Turn power on and check to verify that compressor and condenser fan are running. On freezers, evaporator fans are delayed at start up until the evaporator has pulled down to predetermined temperature. Once fans are running, a switch behind each door will stop fans while door is open.

c. Interior Lights:

In the solid door models, interior lights are actuated by a door switch or switch on the header panel.

d. Temperature Control, Defrost System and Condensate Disposal (See Controller Instructions for more info):

All units are equipped with an electronic control. This control is located on right hand side of the cabinet above the door. The control has six buttons as shown in the picture below.

Freezers are shipped from the factory with control set at -25°C. To change the temp. control setting, press and hold the SET button for 3 seconds. The set value will be displayed and °C will start blinking. Use the Up and Down arrow buttons to change the set point. Push the Set button again to exit.

Freezers are provided with an electric defrost heater actuated by the electronic control. The controls initiates a defrost cycle every 8 hours. For efficient operation, the defrost cycle is temperature and time terminated. Defrost can be manually initiated by pressing and holding the Defrost button for 3 seconds or longer. The control displays dF during the defrost cycle.

Refrigerators do not have a defrost cycles. However, defrosting occurs automatically with each cycle of the compressor. All cabinets are equipped with an automatic overhead condensate disposal system. No outside drain hook up is necessary.

Refrigerators are shipped from the factory with temperature control set at 4°C. To change temperature hold down set key for 3 seconds, press up or down arrow to change set point and press set to



3. MAINTENANCE

a. Cleaning Cabinet Exterior: Cabinets should be cleaned with a solution of mild soap and water. Do not use caustic soap or abrasive cleaners, since these might damage the cabinet finish. If stainless steel surfaces become discolored, scrub by rubbing only in direction of the finish grain. The anodized aluminum interior and exterior should be cleaned with mild soap and water. Do not use steel wool.

b. Cleaning Interior Surfaces: The inside of the cabinet is coated with baked-on vinyl or stainless steel. To clean, use mild soapy water and cloth, or sponge.

c. Condenser: For efficient operation, it is recommended that the condenser coil and fans be cleaned every 4 to 6 months. Remove grille for access. Vacuum clean front surface of coil thoroughly or direct forced air through condenser from the rear. If necessary, use a stiff bristled brush to loosen dirt.

d. Condensate Evaporation Pan: The condensate evaporation pan (See Fig. 4) must be cleaned periodically to prevent foul odors and to operate efficiently. Vacuum clean if dry or sponge clean with soapy water.

4. SERVICING

All YSA products are inspected and performance tested at the factory before crating to insure years of satisfactory operation. However, in time, minor servicing will be necessary to maintain or restore peak performance of the cabinet in particular applications. Problems usually encountered and their corrections are as follows.

Problem: High temperature.

Correction: (1) Inside air duct might be blocked with product. Be sure space between shelves, in center of cabinet, is open for proper air circulation, (2) Very high usage, or door left open, can raise temperature. Give cabinet time to pull back down. (3) Cabinet might be in defrost cycle; check timer box for position of cam. (4) Condenser could be clogged with dirt, cutting down air flow. Check and clean, if dirty.

Problem: Doors will not close properly.

Correction: (1) Door hinges, particularly on bottom, can get dry and caked with dirt, Etc. Clean, if needed, and lubricate wear surfaces lightly. (2) If cabinet has been moved, it might not be level. Re-level, if needed.

In case additional service is required, a qualified service agency or the factory should be contacted. When calling for service at the factory, be prepared to give serial and model numbers of the cabinet to insure prompt attention.

SHELF SUPPORT LOCATION ILLUSTRATION

ILB-1621
ALL MTS

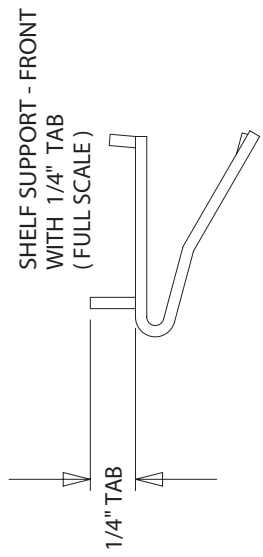
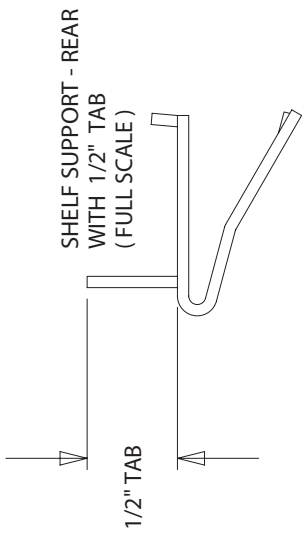
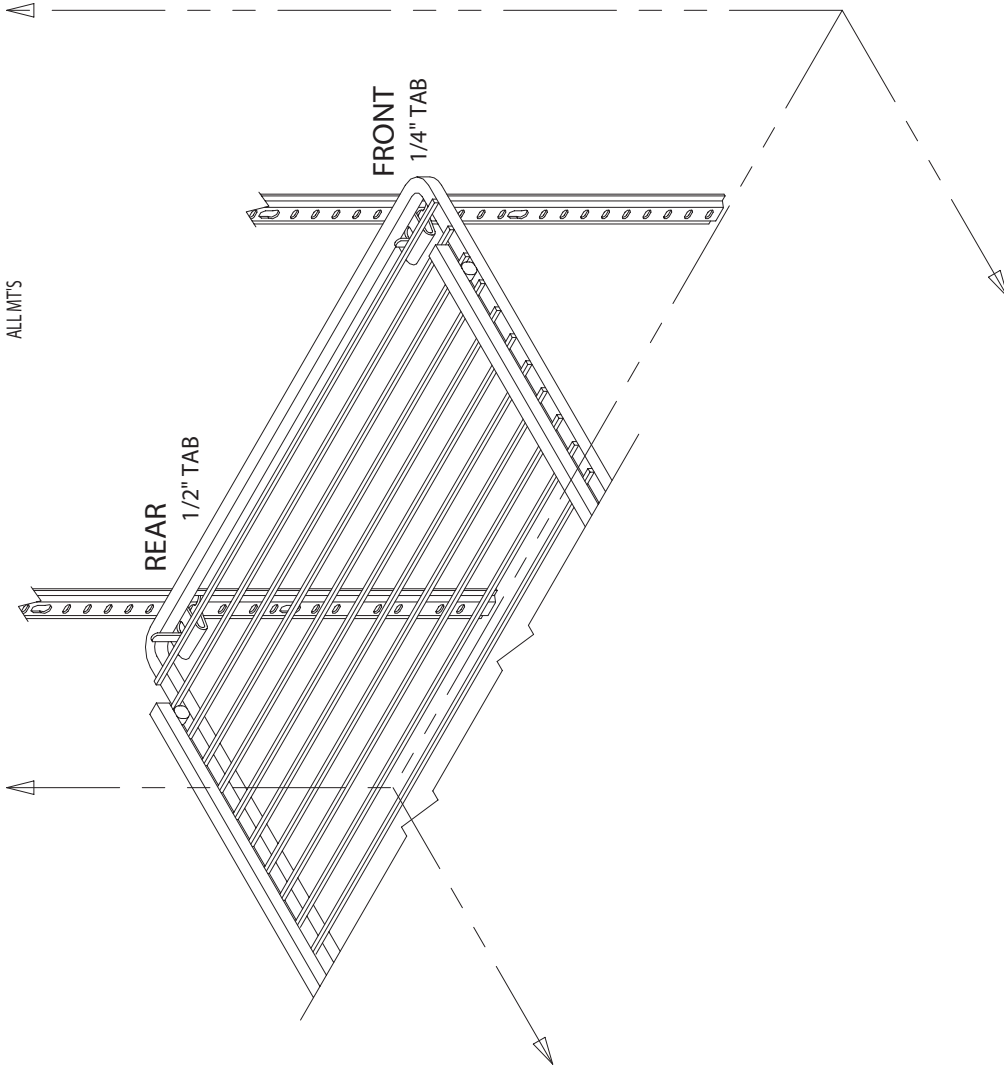

-- NOTES & INSTRUCTIONS --

1. PLACE SHELF SUPPORTS WITH 1/4" TABS INTO PILASTER AT DESIRED POSITION.
(NOTE THAT SUPPORTS WITH 1/4" TABS ARE LOCATED AT FRONT ONLY)
2. PLACE SHELF SUPPORTS WITH 1/2" TABS INTO PILASTER AT DESIRED POSITION.
(NOTE THAT SUPPORTS WITH 1/2" TABS ARE LOCATED AT BACK ONLY)

SHELF CLIP INSTALLATION

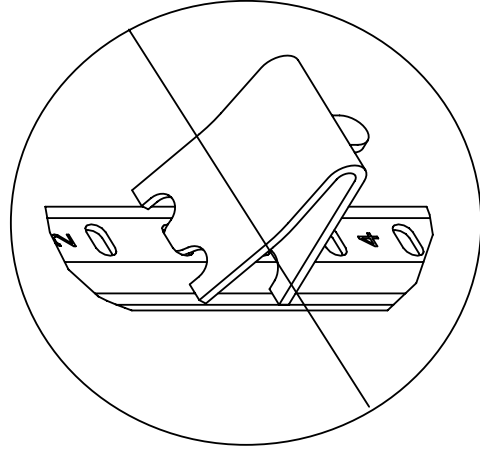

IMPROPERLY INSTALLED
CLIP (UPSIDE DOWN)

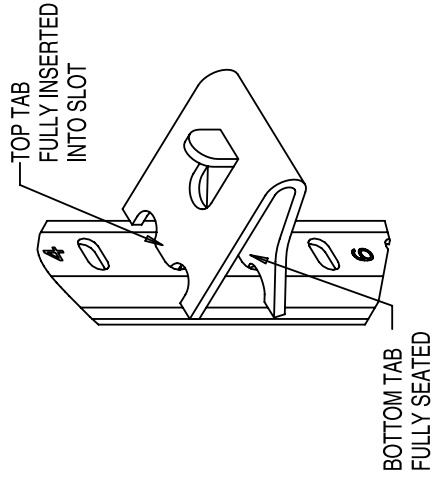

PROPERLY INSTALLED
CLIP

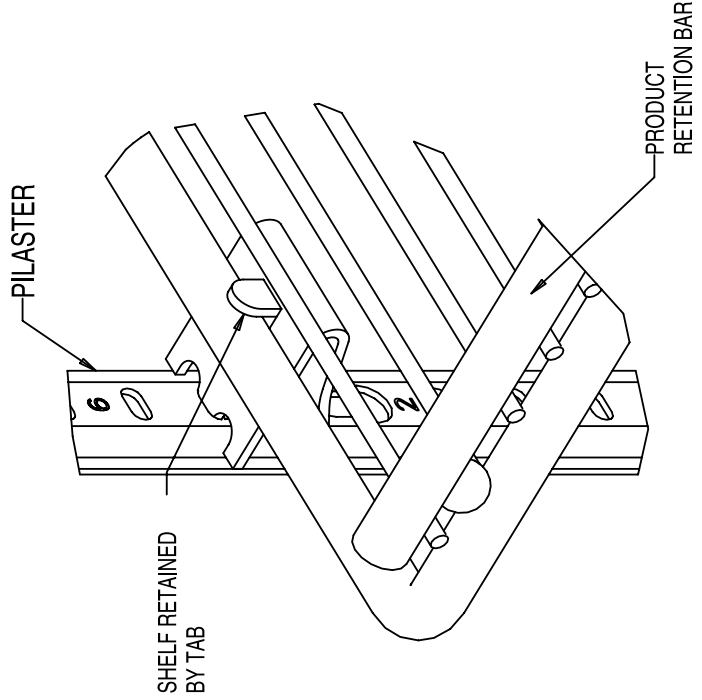
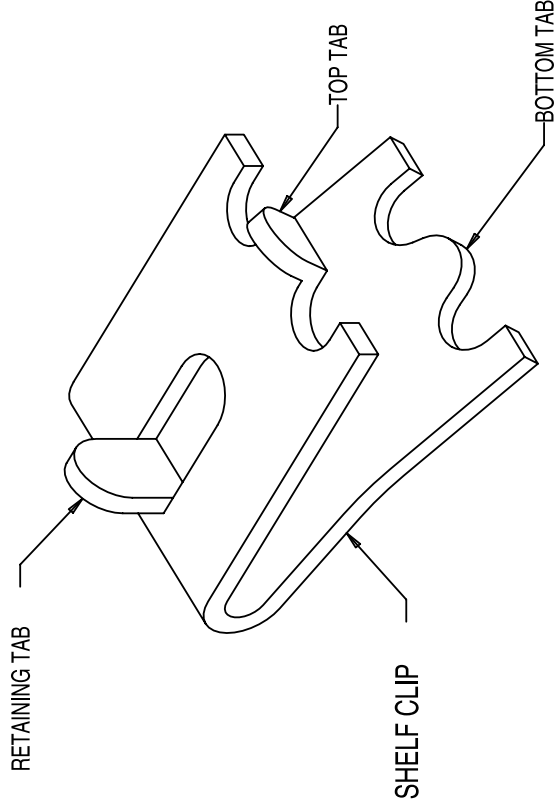

INSTALLATION INSTRUCTIONS

- 1) DETERMINE PROPER LOCATION FOR SHELF CLIPS. THE REFERENCE NUMBERS ON THE PILASTER CAN SERVE AS A GUIDE TO ENSURE ALL CLIPS ARE PROPERLY LOCATED.
- 2) INSERT TOP TAB OF THE SHELF CLIP INTO THE DESIRED HOLE OF THE PILASTER. THE RETAINING TAB SHOULD BE FACING UPWARDS AS SHOWN.
- 3) ROTATE THE CLIP DOWNWARDS AND INSERT THE BOTTOM TAB INTO THE APPROPRIATE HOLE ON THE PILASTER. THE CLIP MAY NEED TO BE SQUEEZED SLIGHTLY DURING INSTALLATION.
- 4) INSTALL ALL REMAINING CLIPS AS DESCRIBED ABOVE.
- 5) INSTALL SHELVES ONTO CLIPS WITH THE PRODUCT RETENTION BAR FACING UPWARD. BE CAREFUL NOT TO DISLodge CLIPS DURING SHELF INSTALLATION.
- 6) SHELVES MUST BE PLACED SUCH THAT THE RETAINING TAB ON THE SHELF CLIP CAPTURES THE SHELF AS SHOWN.
- 7) PRIOR TO LOADING THE SHELF. ENSURE THAT THE SHELF IS RESTING ON EACH OF 4 CLIPS AND THE CLIPS ARE INSTALLED AS SHOWN.

WARNING

- IMPROPER SHELF CLIP INSTALLATION MAY CAUSE SHELF AND/OR PRODUCT TO FALL RESULTING IN DAMAGE TO THE UNIT AND BODILY INJURY.
- DO NOT OVERLOAD THE SHELVES. THE UNIT IS DESIGNED TO UTILIZE ALL SHELVES THAT ARE SUPPLIED IN AN EQUALLY SPACED MANNER. IF LESS SHELVES OR A DIFFERENT CONFIGURATION IS DESIRED, CONTACT THE MANUFACTURER TO ENSURE SHELF OVERLOADING WILL NOT OCCUR.

METHODS FOR CLEANING STAINLESS STEEL

	CLEANING AGENT*	METHOD OF APPLICATION**	EFFECT ON FINISH
Routine Cleaning	Soap, ammonia or detergent and water.	Sponge with cloth, then rinse with clear water and wipe dry.	Satisfactory for use on all finishes.
Stubborn spots and stains, baked-on splatter, and other light discoloration's.	Revere Ware cleaner, Twinkle, or Cameo stainless steel cleaner.	Apply with damp sponge or cloth. Rub with damp cloth.	Satisfactory for use on all finishes if rubbing is light. Use in direction of polish lines.
	Goddard's Stainless Steel Care, Revere Ware Stainless Steel Cleaner, Soft-Scrub.	Apply with damp sponge or cloth.	Use in direction of polish lines. May scratch or dull highly polished finishes.
	Household cleansers, such as Old Dutch, Zud, Bon Ami, Ajax, Comet	Rub with a damp cloth. May contain chlorine bleaches. Rinse thoroughly after use. Rub with a damp cloth.	
Heat tint or heavy discoloration	Revere Ware Stainless Steel Cleaner, Goddard's Stainless Steel Care.	Apply with damp sponge or cloth.	
Burnt-on foods and grease, fatty acids milkstone (where swabbing or rubbing is not practical)	Easy-Off Oven Cleaner	Apply generous coating. Allow to stand for 10 to 15 minutes. Rinse. Repeated application may be necessary.	Excellent removal. Satisfactory for use on all finishes.
Hard water spots and scale	Vinegar	Swab or wipe with cloth. Rinse with water and dry.	Satisfactory for use on all finishes.

*Use of brand names is intended only to indicate a type of cleaner. This does not constitute an endorsement. Nor does the omission of any brand name cleaner imply its inadequacy. Many products named are regional in distributor and can be found in local supermarkets, department and hardware stores.

**It is emphasized that all products should be used in strict accordance with instructions on package.

1. Use the mildest cleaning procedure that will do the job efficiently and effectively.
2. Always rub in the direction of polish lines for maximum effectiveness and to avoid marring the surface.
3. Use only a soft cloth, sponge, fibrous brushes, plastic or stainless steel pads for cleaning and scouring.
4. Rinse thoroughly with fresh water after every cleaning operation.
5. Always wipe dry to avoid water marks.
6. **Never use common steel wool pads, these will cause rust!**

SERVICE AND ANALYSIS
CHART

REFRIGERATION
SYSTEM

MALFUNCTION	POSSIBLE CAUSE	SOLUTION
Compressor will not start - no hum	<ol style="list-style-type: none"> 1. Line cord not plugged in. 2. Fuse removed or blown. 3. Overload protector tripped. 4. Temp control stuck in open position. 5. Wiring improper or loose. 	<ol style="list-style-type: none"> 1. Plug in the cord. 2. Replace fuse. 3. Refer to electrical section. 4. Repair or replace temp control. 5. Check wiring against diagram.
Compressor will not start - hums but trips on overload protector.	<ol style="list-style-type: none"> 1. Low voltage to unit 2. Relay failing to close 3. Starting capacitor defective. 4. Improperly wired. 	<ol style="list-style-type: none"> 1. Determine reason and correct 2. Determine reason and correct, replace if necessary 3. Determine reason and replace 4. Check wiring against diagram
Compressor starts but does not switch off of start winding.	<ol style="list-style-type: none"> 1. Low voltage to unit. 2. Relay failing to open. 3. Run capacitor defective 4. Comp Mt winding is open or shorted 	<ol style="list-style-type: none"> 1. Determine reason and correct. 2. Determine reason and correct, replace if necessary. 3. Determine reason and replace. *4. Determine cause. correct, and replace comp
Compressor starts and runs, but short cycles on overload protector.	<ol style="list-style-type: none"> 1. Additional current passing through overload protector. 2. Low voltage to unit. 3. Overload protector defective. 4. Run capacitor defective. 5. Excessive discharge pressure. 6. Compressor too hot - return gas hot. 	<ol style="list-style-type: none"> 1. Check wiring diagram. Check for added fan motors, pumps, etc. connected to wrong side of protector. 2. Determine reason and correct. 3. Check current, replace protector. 4. Determine reason and replace. *5. Check ventilation, restrictions in cooling medium, restrictions in refrigeration system. *6. Check refrigerant charge (fix leak if necessary). Check air flow across condenser.
Unit runs OK, but short cycles.	<ol style="list-style-type: none"> 1. Overload protector. 2. Cold control. 3. Overcharge. 4. Air in system. 5. Undercharge. 	<ol style="list-style-type: none"> 1. Check wiring diag for correct wiring 2. Differential set too close. *3. Reduce refrigerant charge. *4. Recover and recharge. *5. Fix leak and recharge with refrigerant.
Unit operates long or continuously.	<ol style="list-style-type: none"> 1. Dirty condenser 2. Shortage of refrigerant. 3. Temp control contacts stuck or frozen 4. Evaporator coil iced. 5. Restriction in refrigeration system. 	<ol style="list-style-type: none"> *1. Clean condenser 2. Fix leak, add charge, correct charge 3. Replace Temp control *4. Defrost 5. Determine location and remove.
Start capacitor open, shorted or blown.	<ol style="list-style-type: none"> 1. Relay contacts not opening properly. 2. Low voltage to unit. 3. Improper relay. 	<ol style="list-style-type: none"> 1. Replace relay 2. Determine reason and correct. 3. Replace.
Run capacitor open, shorted or blown.	<ol style="list-style-type: none"> 1. Improper capacitor. 2. Excessively high line voltage (110% of rated max). 	<ol style="list-style-type: none"> 1. Determine correct size and replace. 2. Determine reason and correct.
Relay defective or burned out.	<ol style="list-style-type: none"> 1. Incorrect relay. 2. Line voltage too high or too low. 3. Relay being influenced by loose vibrating mounting. 	<ol style="list-style-type: none"> 1. Check and replace. 2. Determine reason and replace. 3. Remount rigidly.
Space temperature too high.	<ol style="list-style-type: none"> 1. Control setting too high. 2. Overcharged with refrigerant. 3. Inadequate air circulation. 	<ol style="list-style-type: none"> 1. Reset control. *2. Recover refrigerant and recharge with proper charge specified on dataplate. 3. Improve air movement.
Cooler freezing beverage.	<ol style="list-style-type: none"> 1. Temperature control 	<ol style="list-style-type: none"> 1. Reset control.
Unit noisy.	<ol style="list-style-type: none"> 1. Loose parts or mountings. 2. Tubing rattle. 3. Bent fan blade causing vibration. 4. Fan motor bearings worn. 	<ol style="list-style-type: none"> 1. Find and tighten. 2. Reform to be free of contact. 3. Replace blade. 4. Replace motor.

Instructions to change Controller from Celsius to Fahrenheit For Freezer



Press and hold **[DOWN]** + **[SET]**, until **[Hy]** appears on display,
Now release the buttons



Press and hold **[DOWN]** + **[SET]** again, until **[Pr2]** appears

The **[Pr2]** will appear briefly and disappear when you let go of the buttons

Release the buttons, and the display will return to [Hy]



Press [UP] or [DOWN] until [CF] is displayed, press [SET]
Change [C] to [F], and press [SET]. This changes Celsius to Fahrenheit



Then press [UP] or [DOWN] until [LS] is displayed, press [SET]
(Low set point limit)
Change the value to [-22] for factory setting, and press [SET]



Then press **[UP]** or **[DOWN]** until **[US]** is displayed, press **[SET]**
(Upper set point limit)

Change the value to **[32]** for factory setting, and press **[SET]**



Then press **[UP]** or **[DOWN]** until **[ALU]** is displayed, press **[SET]**
(Upper alarm setting)

Change the value to **[23]** for factory setting, and press **[SET]**



Then press [**UP**] or [**DOWN**] until [**ALL**] is displayed, press [**SET**]
(Lower alarm setting)
Change the value to [**-18**] for factory setting, and press [**SET**]



Then press [**UP**] or [**DOWN**] until [**Hy**] is displayed, press [**SET**]
(Differential)
Change the value to [**4**] for factory setting, and press [**SET**]



Do not push any other buttons and let the display return back to normal operation

Now press and hold [**SET**] until F blinks,
Change value to [**-11**] for factory setting, this will set your set point
Your unit will run between -11°F and -7°F

Now your unit should be working correctly.

Then press [UP] or [DOWN] until [dtE] is displayed, press [SET]
(Defrost Termination Temperature)
Change the value to [50] for factory setting, and press [SET]



Instructions to change Controller from Celsius to Fahrenheit For Refrigerator



Press and hold **[DOWN]** + **[SET]**, until **[Hy]** appears on display,
Now release the buttons



Press and hold **[DOWN]** + **[SET]** again, until **[Pr2]** appears

The **[Pr2]** will appear briefly and disappear when you let go of the buttons.

Release the buttons, and the display will return to **[Hy]**



Press **[UP]** or **[DOWN]** until **[CF]** is displayed, press **[SET]**
Change **[C]** to **[F]**, and press **[SET]**. This changes Celsius to Fahrenheit



Then press **[UP]** or **[DOWN]** until **[LS]** is displayed, press **[SET]**
(Low set point limit)
Change the value to **[30]** for factory setting, and press **[SET]**



Then press [UP] or [DOWN] until [US] is displayed, press [SET]
(Upper set point limit)
Change the value to [60] for factory setting, and press [SET]



Then press [UP] or [DOWN] until [ALU] is displayed, press [SET]
(Upper alarm setting)
Change the value to [50] for factory setting, and press [SET]



Then press [**UP**] or [**DOWN**] until [**ALL**] is displayed, press [**SET**]
(Lower alarm setting)
Change the value to [**32**] for factory setting, and press [**SET**]



Then press [**UP**] or [**DOWN**] until [**Hy**] is displayed, press [**SET**]
(Differential)
Change the value to [**4**] for factory setting, and press [**SET**]



Do not push any other buttons and let the display return back to normal operation

Press and hold [**SET**] until F blinks
Change value to [**39**] for factory setting, this will set your set point
Your unit will run between 39°F and 43°F

Now your unit should be working correctly.

WARRANTY INFORMATION

WARRANTY POLICY

Yamato Scientific America warrants, from the date of shipment from warehouse in Cincinnati, Ohio, U.S.A., for a period of one (1) year. All products, parts and materials shall be free of defects in material and workmanship under normal use consistent with the product instructions. This product warranty does not apply to products purchased from unauthorized resellers/distributors.

Yamato reserves the right to inspect the product under claim before having an obligation to repair or replace the defective unit covered by this warranty. All costs of shipping to Yamato for inspection shall be borne solely by the purchaser. Products repaired or replaced under the terms of the warranty may be refurbished or new product will be provided at the discretion of Yamato.

Warranty Conditions

This warranty shall have force and effect only if all items are used with proper circuits, voltages, and frequencies and the operation thereof is in accordance with instructions furnished by the manufacturer.

This warranty shall not extend to such parts as refrigerants, finishes, belts, and dryers.

This warranty shall not extend to ordinary wear and tear, or ordinary refrigeration service and refrigeration adjustments, unless specifically included in the equipment purchase contract.

This warranty does not apply to equipment or parts which fail because of abuse, accident, alteration, misuse, erosion, improper installation, or improper replacement of a repaired item.

The buyer assumes all risks for results obtained from these products, whether used alone or in combination with other items. It is expressly understood that we are not responsible and will not be held liable for damage and/or injury caused using our products.

WARRANTY INFORMATION

WARRANTY POLICY CONTINUED

Product Return Policy

If you are not satisfied with your purchase and wish to make a return, contact our customer service to inquire about a Return of Merchandise Authorization Number (RMA). Merchandise returned without an RMA number will not be accepted and will be returned to the sender. Return requests must be made within 15 days of the customer's receipt of the merchandise.

All returns must be unused and in unopened original packaging and include all items and manuals originally shipped.

The purchaser is responsible for the shipping cost of return shipment. Insurance on the return shipment is required. Damage or loss of merchandise during shipping is the responsibility of the sender. Returned shipments that arrive damaged will be returned to the sender, and credit will not be rendered.

All returned products, parts and materials are subject to a 25% restocking fee. Shipping and handling cost are non-refundable. All retrofitted, customized and special order item sales are final and non-returnable.

In Case of Request for Repair

If the failure occurs, stop the operation, turn OFF the power switch, and unplug the power plug. Please contact the sales agency that this unit was purchased, or Yamato Scientific's sales office.

< Check following items before contact >

- ◆ Model Name of Product
- ◆ Serial Number
- ◆ Purchase Date
- ◆ Issue (as detailed as possible)

Responsibility

Please follow instructions in this document when using this unit. Yamato Scientific has no responsibility for accidents or breakdown of device due to failure to comply. Never conduct what this document forbids as unexpected accidents or breakdown may result.

Yamato Scientific America Inc.
925 Walsh Ave, Santa Clara, CA 95050
Tel: 1-800-292-6286 / 408-235-7725
<http://www.yamato-usa.com>

For customer service:
Email: customerservice@yamato-usa.com
For technical support:
Email: technical@yamato-usa.com