



Rotary Evaporator

REV202M series

Instruction Manual

First Edition

Thank you for choosing REV202M series Rotary Evaporator from Yamato Scientific Co., Ltd.

- For proper equipment operation, please read and become thoroughly familiar with this instruction manual before use. Always keep equipment documentation safe and close at hand for convenient future reference.



Warning: Read instruction manual warnings and cautions carefully and completely before proceeding. Read instruction manual thoroughly before operation.

Yamato Scientific Co. Ltd.

Printed on recycled paper

REV202M Series Product Line-Up

REV series has a model for each destination, and some specifications differ by models.

Note that availability of some options also differs.

Applicable models are stated for contents exclusive to some models.

Model	Vacuum controller Model *1	Power supply	Destination	Language
REV202M	VR102S	100 V \pm 5 % 1 A 50/60 Hz Type A plug (PSE)	Japan	Japanese
REV202M-A	VR102S-A	115 V \pm 5 % 1 A 60 Hz Type A plug (UL)	U.S.A.	English
REV212M-A	VR102S-A	230 V \pm 5 % 1 A 60 Hz M4 ring terminals (UL)		
REV212M-B	VR102S-B	220 V \pm 5 % 1 A 50 Hz Type O plug (CCC)	China	Chinese
REV212M-D	VR102S-D	220 V \pm 5 % 1 A 60 Hz Type SE plug (KC)	Korea	English

Model number is printed on Model/Rating label affixed on the side of unit.

*1 Model No. of vacuum controller embedded in this unit. See VR102S instruction manual for instructions on operating Vacuum controller.

REV202M series

Model/Rating label location

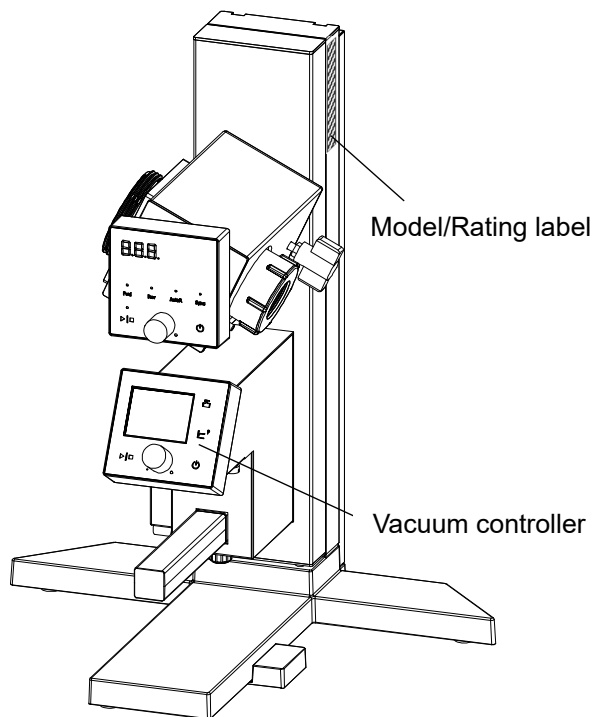

Shape of each plug

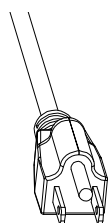

Type A

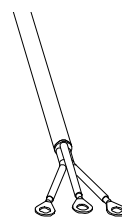

M4 ring terminals

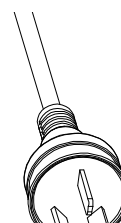

Type O

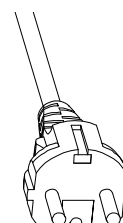

Type SE

TABLE OF CONTENTS

REV202M Series Product Line-Up	2
1. SAFETY PRECAUTIONS	1
Explanation of Symbols	1
Symbol Glossary.....	2
Warnings and Cautions	3
Wireless Interlocking.....	5
List of Residual Risks	6
2. COMPONENT NAMES AND FUNCTIONS	8
Main Unit.....	8
Accessories	10
Control Panel 1 (Rotary Evaporator)	11
Display Characters	11
Control Panel 2 (Vacuum Controller).....	12
LCD.....	13
Piping/Power System Diagram	14
A. When performing vacuum control by vacuum control solenoid valve.....	14
B. When performing vacuum control by Vacuum pump control unit G and vacuum control solenoid valve.	15
C. When performing vacuum control by Vacuum pump control unit and vacuum control solenoid valve.	15
3. PRE-OPERATION PROCEDURES.....	16
Installation Precautions.....	16
Installation Procedure	19
4. OPERATION PROCEDURES	33
Operation Procedure	33
User Setting (Control Panel 1).....	35
Rotation Mode (Control Panel 1)	36
Auto Inversion Time Setting (Control Panel 1)	37
Auto-resume Function (Control Panel 1)	38
LED Brightness Setting (Control Panel 1)	39
Vacuum Controller Connection (Control Panel 1).....	40
Start Operation	41
Operation Stop.....	42
5. HANDLING PRECAUTIONS	44
Warnings and Cautions	44
6. INSPECTION AND MAINTENANCE	46
Precautions before Inspection	46
Precautions in Daily Maintenance	46

Maintenance and Inspection.....	46
7. EXTENDED STORAGE AND DISPOSAL	47
Extended Storage/Disposal	47
Disposal Considerations	47
8. TROUBLESHOOTING	48
Reading Error Codes (Control Panel 1)	48
Reading Error Codes (Control Panel 2)	49
Troubleshooting Guide	50
9. SERVICE & REPAIR	52
Requests for Repair	52
10. SPECIFICATIONS	53
Specifications.....	53
List of Consumable Parts.....	54
11. OPTIONAL ACCESSORIES.....	55
Consumables/Replacement Parts/Options	55
List of Options.....	58
12. REFERENCE DATA	61
Solvent Boiling Point.....	61
13. LIST OF HAZARDOUS SUBSTANCES	62
14. STANDARD INSTALLATION MANUAL.....	63

1. SAFETY PRECAUTIONS

Explanation of Symbols

A Word Regarding Symbols

Various symbols are provided throughout this text and on equipment to ensure safe operation. Failure to comprehend the operational hazards and risks associated with these symbols may lead to adverse results as explained below. Become thoroughly familiar with all symbols and their meanings by carefully reading the following text regarding symbols before proceeding

 **Warning** Signifies a situation which may result in serious injury or death (Note 1.)

 **Caution** Signifies a situation which may result in minor injury (Note 2) and/or property damage (Note 3.)

(Note 1) Serious injury is defined as bodily wounds, electrocution, bone breaks/fractures or poisoning, which may cause debilitation requiring extended hospitalization and/or outpatient treatment.

(Note 2) Minor injury is defined as bodily wounds or electrocution, which will not require extended hospitalization or outpatient treatment.

(Note 3) Property damage is defined as damage to facilities, equipment, buildings or other property.

Symbol Meanings



Signifies warning or caution.
Specific explanation will follow symbol.



Signifies restriction.
Specific restrictions will follow symbol.



Signifies an action or actions which operator must undertake.
Specific instructions will follow symbol.

1. SAFETY PRECAUTIONS

Symbol Glossary

WARNING / CAUTION



General



Danger!: Blast Hazard



Caution: Toxic Chemicals

RESTRICTION



General Restriction



Do Not Disassemble

ACTION



General Action Required



Connect Ground Wire



Level Installation



Disconnect Power



Inspect Regularly

1. SAFETY PRECAUTIONS

Warnings and Cautions



WARNING



Install in a location free of flammables and explosives

Never install or operate unit in a flammable or explosive gas atmosphere. See "LIST OF HAZARDOUS SUBSTANCES" (P.62) for information on flammable and explosive gases.



Ground wire **MUST** be connected properly

- Ground wire must be connected to a proper grounding line or terminal in order to avoid electric shock.
- Never connect ground wire to gas lines or water pipes. Fire, accident or equipment malfunction may result.
- Never connect ground wire to telephone grounding lines or to lightning conductor rods. Fire or electric shock may result.
- Never insert multiple plugs into a single outlet. Doing so may result in power cable overheating, fire or drop in voltage.



Turn OFF (○) power immediately when an abnormality occurs

If unit begins emitting smoke or abnormal odors for reasons unknown, turn OFF (○) power immediately, disconnect power cable from power supply, and contact original dealer of purchase for assistance.

Continuing to operate without addressing abnormalities may cause fire or electric shock, resulting in serious injury or death. Never attempt to disassemble or repair unit. Repairs should always be performed by a certified technician.

1. SAFETY PRECAUTIONS

Warnings and Cautions



Handle power cable with care



- Do not operate unit with power cable bundled or tangled. Operating unit with the power cable bundled or otherwise tangled, may cause power cable to overheat and/or catch fire.
- Do not modify, bend, forcibly twist or pull on power cable. Fire or electric shock may result.
- Do not risk damage to power cable by positioning it under desks or chairs, or by allowing it to be pinched in between objects. Fire or electric shock may result.
- Do not place power cable near kerosene/electric heaters or other heat-generating devices. Doing so may cause power cable insulation to overheat, melt and/or catch fire, which may result in electric shock.
- Turn OFF (○) power immediately and disconnect from facility terminal or outlet, if power cable becomes partially severed or damaged in any way. Contact original dealer of purchase for information about replacing power cable. Failure to do so may result in fire or electric shock.
- Always connect power cable to appropriate facility outlet or terminal.



Exercise caution when handling flammable chemicals

Unit is NOT fire or blast resistant. When processing flammable samples, be sure to provide adequate ventilation and not to allow anything that may be a source of fire or ignition (static electricity, etc.) approached. Do not use this unit in an atmosphere of substances shown in "LIST OF HAZARDOUS SUBSTANCES" (P.62). Never vaporize explosive substances. Fire or explosion causing serious injury or death may result.



Exercise caution when handling toxic, harmful chemicals

When using toxic chemicals, operating in a fume hood or installing exhaust system is strongly recommended. Failure to do so may lead to serious accident.



DO NOT operate equipment during thunderstorms

In the event of a thunderstorm, turn OFF (○) power and disconnect power cable immediately. A direct lightning strike may cause equipment damage, fire or electric shock, resulting in serious injury or death.

1. SAFETY PRECAUTIONS

Wireless Interlocking



Precautions regarding radio waves

This unit is a Technical Standards Conformity certified product.



R 201-190693

CMIIT ID : 2020DJ2764

FCCID:2AUMD-ESP-07S

Certified standards
Technical Conformity: Japan
CMIIT: China
FCC: U.S.A

This unit uses the frequency band of 2.4 GHz. This frequency band is used in microwave ovens, industrial/scientific/medical equipment. This is also used by radio stations, licensed premises radio stations for identifying mobile objects utilized in factory production lines, etc., and by unlicensed radio stations such as specified low power radio stations, amateur radio stations, etc. (hereinafter "other radio stations").

- ① Make sure that no other radio stations are operating nearby.
- ② In the event that radio wave interference occurs between this unit and another radio station, immediately relocate this unit, or terminate the operation (stop emitting radio waves).
- ③ If there are radio wave interference or any other problems, contact original dealer of purchase for assistance.

Certification based on the Radio Law

Wireless device embedded in this unit has been certified as a radio equipment for low-power data communication based on the Radio Law. Certification marking is on the radio equipment. There is no need of a radio station license for using this unit. However, doing the following provides penalties by law. Yamato Scientific Co., Ltd. assumes no responsibility for any losses due to violation of the Radio Law arise from negligent use of this unit.

- Disassembling or modifying this unit
- Use in countries not applicable to the radio certificate described on this unit

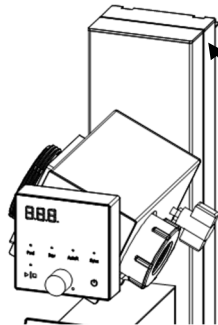

- Model/Rating label
- Technical Standard Conformity Certification marking

* Never export this unit to countries not applicable to the listed radio certificate



DO NOT disassemble or modify equipment

Never attempt to disassemble or modify this unit and peripheral devices. Doing so may cause malfunction, fire, electric shock, or personal injury. Note that any malfunction resulting from unauthorized modifications or customizations to unit will void the warranty. Furthermore, disassembling devices that have radio equipment may violate the Radio law and the Telecommunications Business Act.

1. SAFETY PRECAUTIONS

List of Residual Risks

List of residual risks (instructions for risk avoidance)

This list summarizes residual risks to avoid personal injuries or damages to properties during or related to the use of equipment.

Be sure to fully understand or receive instructions on how to use, maintain and inspect equipment before starting operation.

Loading/Installation				
No.	Degree of risks	Risk description	Protective measures taken by the user	Relevant page
1	WARNING	Fire/ Electric shock	Install in a location free of flammables and explosives.	P.3
2	CAUTION	Fire/ Electric shock	Ground wire MUST be connected properly	P.3
3	WARNING	Fire/ Electric shock	Turn OFF (○) power immediately when an abnormality occurs.	P.3
4	WARNING	Fire/ Electric shock	Handle power cable with care.	P.4
5	WARNING	Fire	Exercise caution when handling flammable chemicals.	P.4
6	WARNING	Fire/ Electric shock	DO NOT disassemble or modify equipment.	P.5
7	WARNING	Fire	Choose an appropriate installation site.	P.16
8	WARNING	Injury	Install unit on a level surface.	P.16
9	WARNING	Fire/ Electric shock	Always connect power cable to appropriate facility outlet or terminal.	P.18
10	WARNING	Fire/ Electric shock	Install in a dry location.	P.18
11	WARNING	Injury	Pay attention to the surroundings whenever operating jack.	P.18
12	WARNING	Injury	Be aware that slide panel may spring up.	P.19
13	WARNING	Injury	Always install glassware and piping with the slide panel lifted up.	P.19
14	CAUTION	Injury	Use caution when handling glassware.	P.24

Use				
No.	Degree of risks	Risk description	Protective measures taken by the user	Relevant page
15	WARNING	Explosion/ Fire	Exercise caution when handling flammable chemicals.	P.44
16	WARNING	Fire/ Electric shock	Turn OFF (○) power immediately when an abnormality occurs.	P.44
17	WARNING	Fire/ Electric shock	DO NOT operate equipment during thunderstorms	P.4

1. SAFETY PRECAUTIONS

List of Residual Risks

Daily inspection/maintenance				
No.	Degree of risks	Risk description	Protective measures taken by the user	Relevant page
19	WARNING	Fire/Electric shock	Be sure to disconnect power cable before daily inspection and maintenance.	P.46
20	WARNING	Fire/Electric shock	NEVER disassemble or modify unit	P.46

Extended storage/disposal				
No.	Degree of risks	Risk description	Protective measures taken by the user	Relevant page
21	WARNING	Fire/Electric shock	Turn OFF (○) power and disconnect power cable.	P.47
22	CAUTION	Injury	Do not leave unit in a location where children may have access	P.47

2. COMPONENT NAMES AND FUNCTIONS

Main Unit

[REV202M series + glass set A]

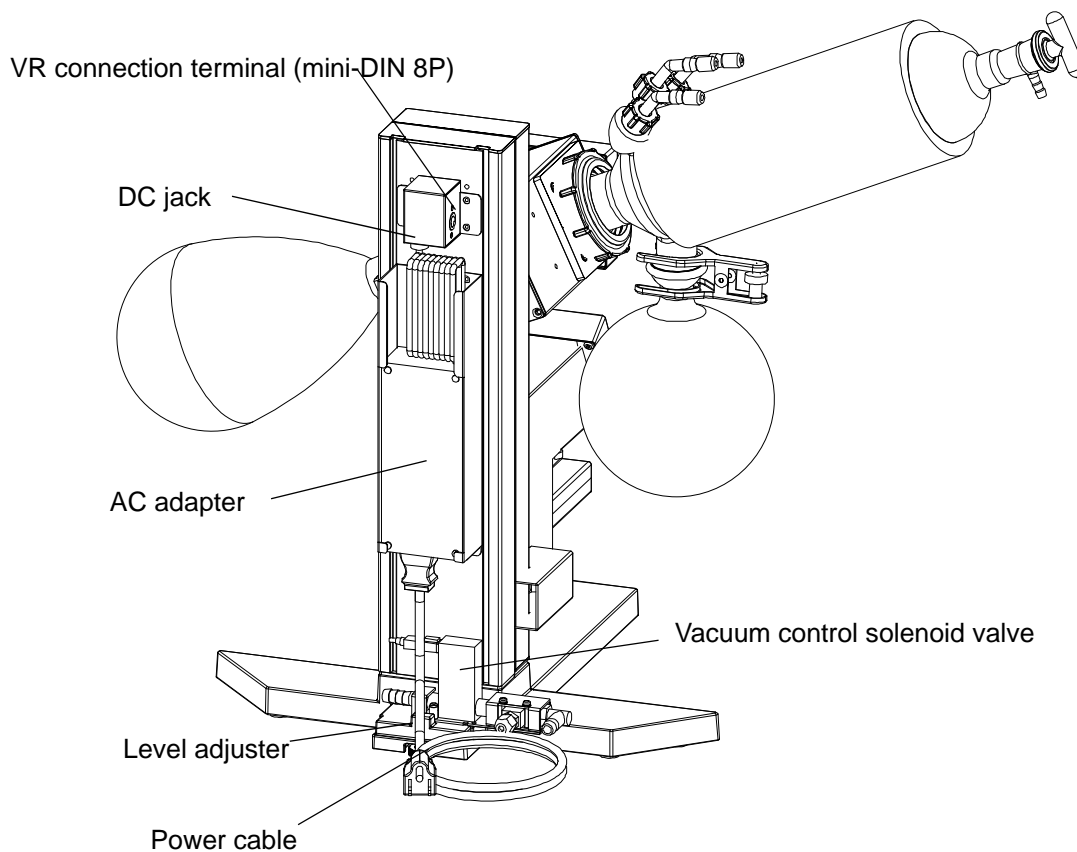
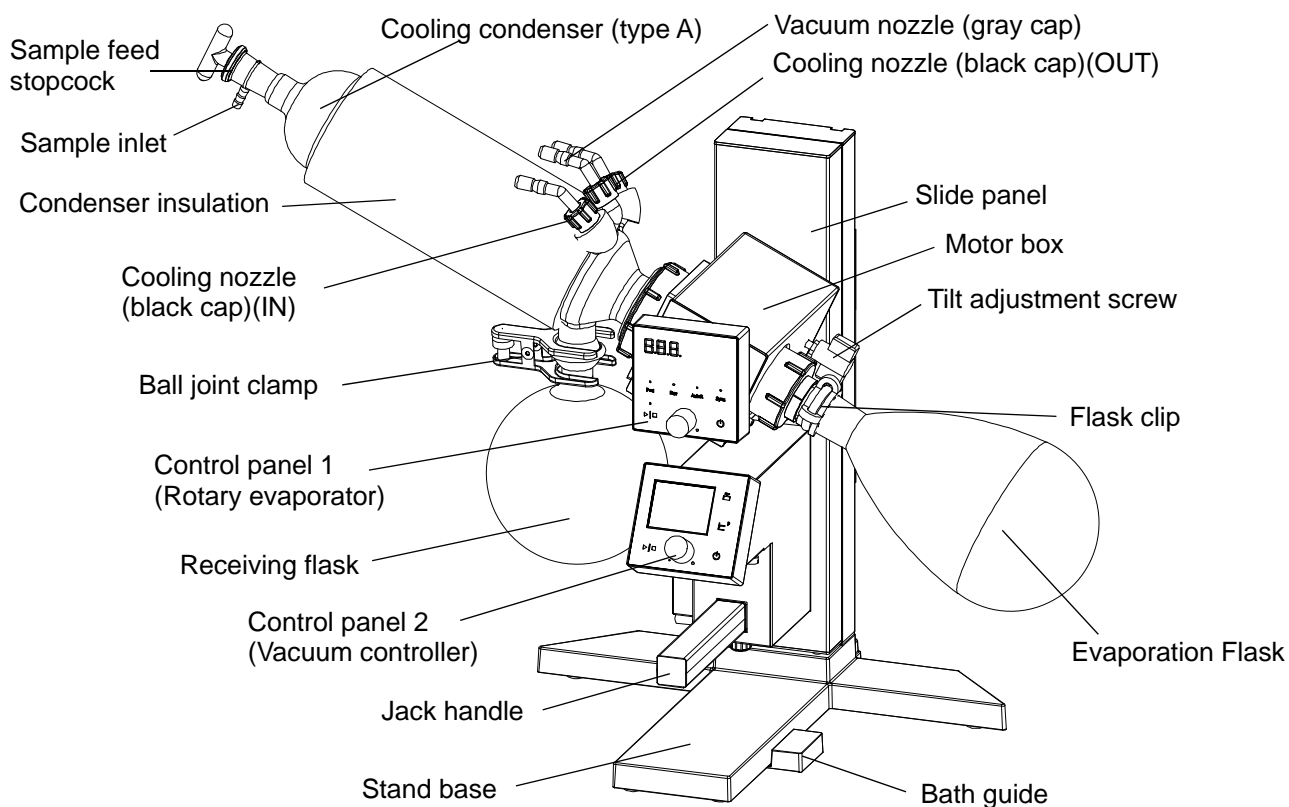

Power cable

* Type of plug differs by models. See "REV202M Series Product Line-Up" for details.

2. COMPONENT NAMES AND FUNCTIONS

Main Unit

[REV202M series + glass set B]

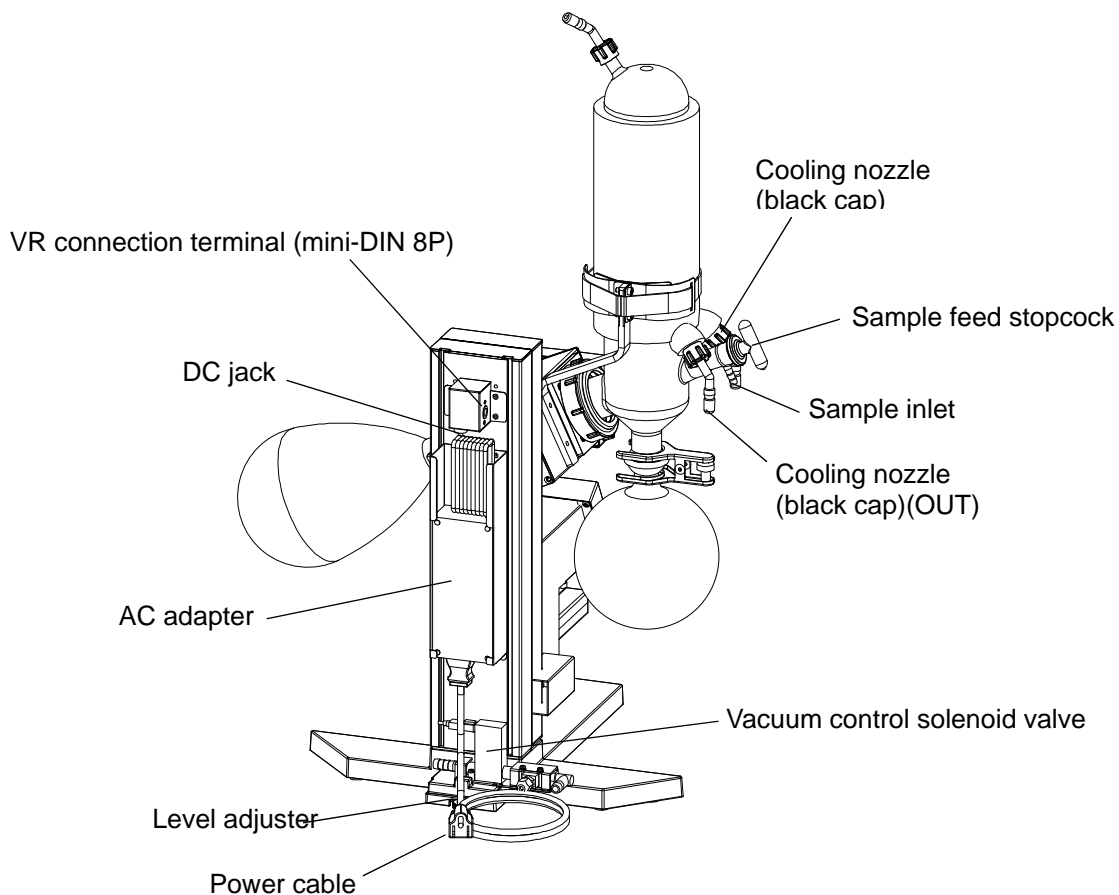
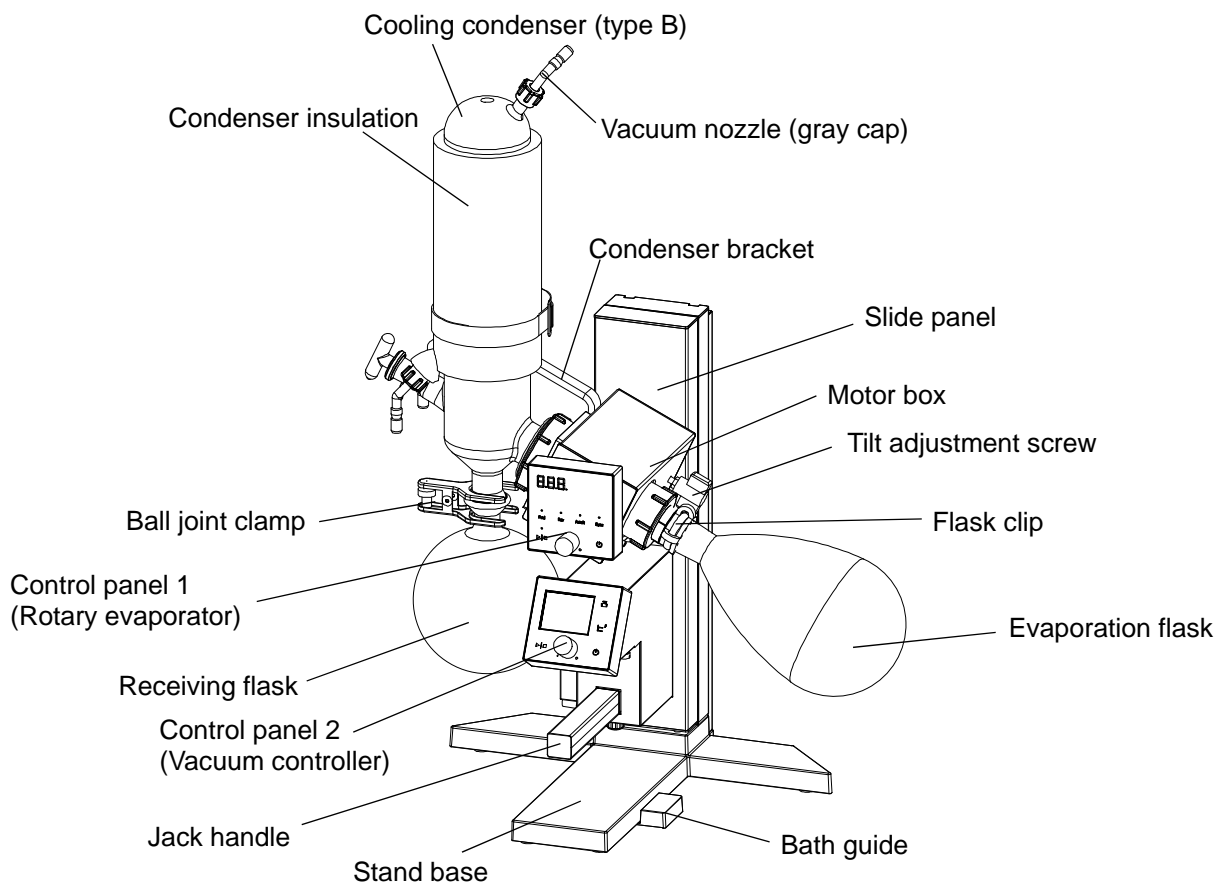

* Type of plug differs by models. See "REV202M Series Product Line-Up" for details.

2. COMPONENT NAMES AND FUNCTIONS

Accessories

Check before operation that all the accessories are complete. Contact original dealer of purchase if anything is missing.

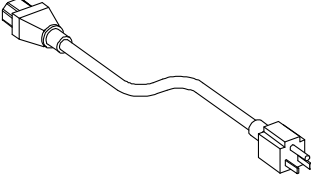
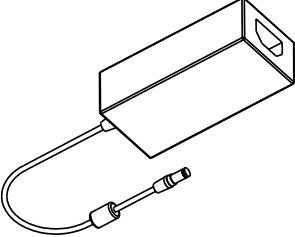
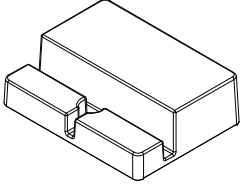
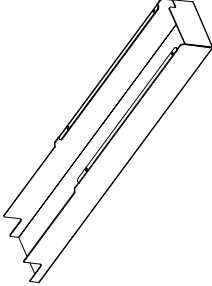
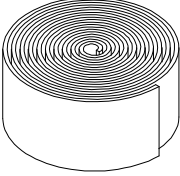
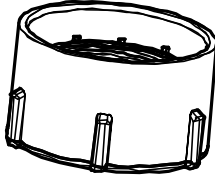
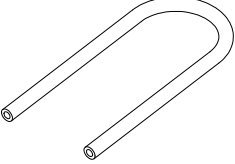
<p>① Power cable (approx. 3 m)</p> 	<p>② AC adapter</p> 	<p>③ Bath guide</p> 	<p>④ Rear cover</p> 
<p>⑤ Tape fastener</p>  <p>Used for binding codes and hoses</p>	<p>⑥ Joint nut</p> 	<p>⑦ Exhaust hose (For purging)</p>  <p>φ7.94 × φ14.3 × 1 m</p>	<p>⑧ REV202M series Instruction Manual</p> <p>⑨ VR102S series Instruction Manual</p> <p>⑩ Warranty card *1</p>

*1: REV202M, REV202M-A, REV212M-A, REV212M-B only

Check the accessories for each condenser unit on the list of condenser unit accessory included with condenser unit.

2. COMPONENT NAMES AND FUNCTIONS

Control Panel 1 (Rotary Evaporator)

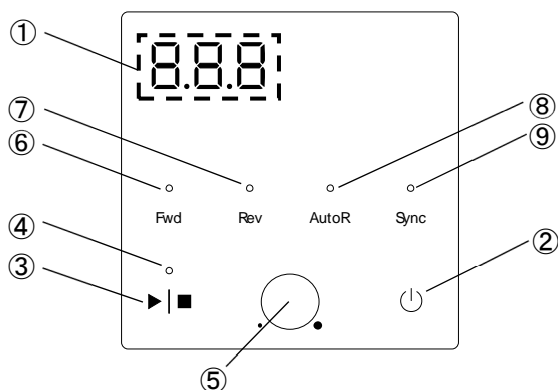
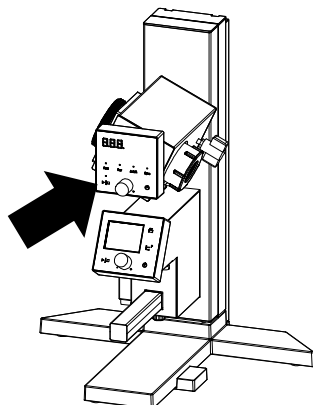

No.	Panel item	Description
①	RPM display	Shows rotation speed reading and setting, and each parameter.
②	Power key	Press to turn ON (I) or OFF (O) power.
③	Run/Stop key	Press to start or stop rotation.
④	Run/Stop lamp	Illuminates during operation.
⑤	Control knob	Turn to increase or decrease set value, scroll items in user setting, and press to switch or finalize settings.
⑥	Fwd lamp	Forward lamp. Illuminates in forward rotation mode
⑦	Rev lamp	Reverse lamp. Illuminates in reverse rotation mode
⑧	AutoR lamp	Auto Rotation lamp. Illuminates in auto inversion mode
⑨	Sync lamp	Synchro lamp. Not used for this unit.

Display Characters

All characters displayed when making settings are defined as follows

Character	Letters	Description
rot	rot	Indicates rotation mode setting. See "Rotation Mode" (P. 36)
4EL	SEC	Indicates time setting for automatic inversion. See "Timed Auto Inversion Mode" (P. 37)
Pon	Pon	Indicates setting of the behavior of unit at power loss restoration. See "Auto-resume Function" (P.38)
d4P	dSP	Indicates LED brightness setting. See "LED Brightness" (P.39)
di	di	Indicates communication setting for vacuum controller See "Vacuum Controller Connection" (P.40)

2. COMPONENT NAMES AND FUNCTIONS

Control Panel 2 (Vacuum Controller)

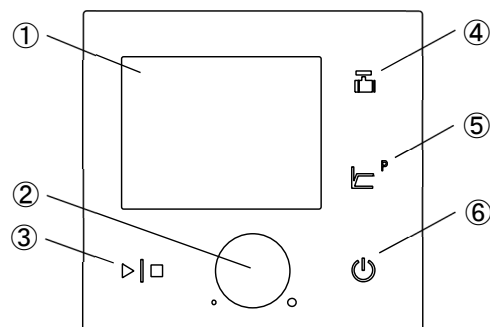
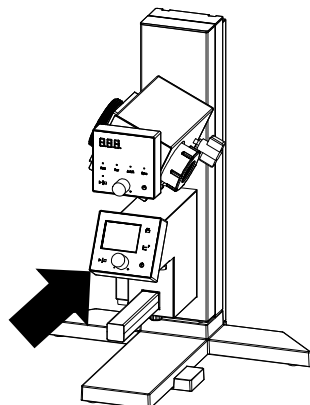

No.	Panel item	Description
①	LCD	Shows pressure reading, operation modes, and connection status.
②	Control knob	Turn to increase or decrease set value, to scroll items in the Menu, and press (hold down) to switch or finalize settings.
③	Run/Stop key	Press to start or stop an operation.
④	Leak key	Opens the leak valve to reduce the degree of vacuum. Press and hold for three seconds or longer to start the manual cleaning operation.
⑤	Hold key	Holds constant at the displayed pressure (only during operation)
⑥	Power key	Press to turn ON (I) or OFF (O) power.

* See VR102S instruction manual for instructions on operating the control panel.

Page on setting screen	Menu item	Description
2/4	Interlock function	Turns ON/OFF the wireless interlock function with vacuum pump Setting parameters: On or Off (Default setting is "On")
	Number of unit connections *2	Shows the number of units connectable to the vacuum pump (cannot be changed). Setting parameters: 1
	Vacuum pump *2	Selects the vacuum pump to use. Setting item: DC N8 ** G / AC Pump (Default setting is "DC N8 ** G")
3/4 *1	ID	Shows communication ID setting (setting cannot be changed) Setting parameters: 1
	Name	Sets the communication name. Setting range: 0000-9999 (Default setting is "0000")
	Password	Sets the communication password. Setting range: 0000-9999 (Default setting is "1111")
	Pairing	Pairs unit with a vacuum pump. Setting parameters: On or Off (Default setting is "Off")
	Reset	Reset Name and Password to the default. Setting parameters: On or Off (Default setting is "Off")

*1 Not displayed when the interlock function is OFF.

*2 Cannot be set or changed when the interlock function is OFF.

2. COMPONENT NAMES AND FUNCTIONS

LCD

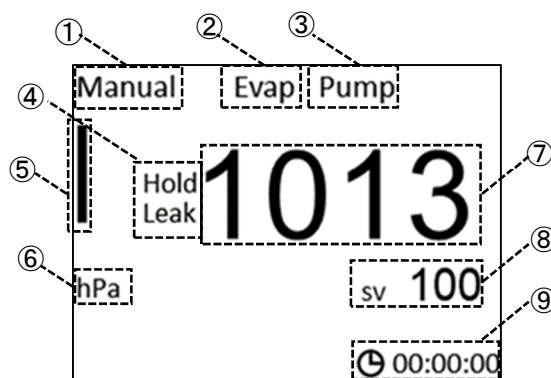

No.	Panel item
①	Displays the current operation mode. <ul style="list-style-type: none"> · Manual (constant operation) · Gradient (gradient decompression, constant operation) · Auto (gradient decompression, target pressure automatic setting)
②	Appears when a rotary evaporator is connected.
③	Appears when a vacuum pump is connected via communication by Vacuum pump control unit/unit G. OFF: Not connected ON: Connected Flash: Connecting
④	Hold: Appears during Hold operation. Leak: Appears while using Leak function.
⑤	Status bar that shows operating status. Indicates operating status in five colors as described below. <ul style="list-style-type: none"> ① Standby: White ② In operation: Green (Manual), Blue (Gradient), Purple (Auto) ③ Cleaning: Light blue ④ Warning: Orange ⑤ Abnormal: Red
⑥	Displays the pressure unit currently selected.
⑦	Displays the current pressure.
⑧	Displays the current vacuum degree setting.
⑨	Displays the duration of the operation. (Maximum 99 hours 59 minutes 59 seconds) Reset at the start of operation, and begins counting. During manual cleaning operation, timer counts the preset time.

2. COMPONENT NAMES AND FUNCTIONS

Piping/Power System Diagram

See Piping/Power System Diagram for connection on main unit and its peripherals.

A. When performing vacuum control by vacuum control solenoid valve

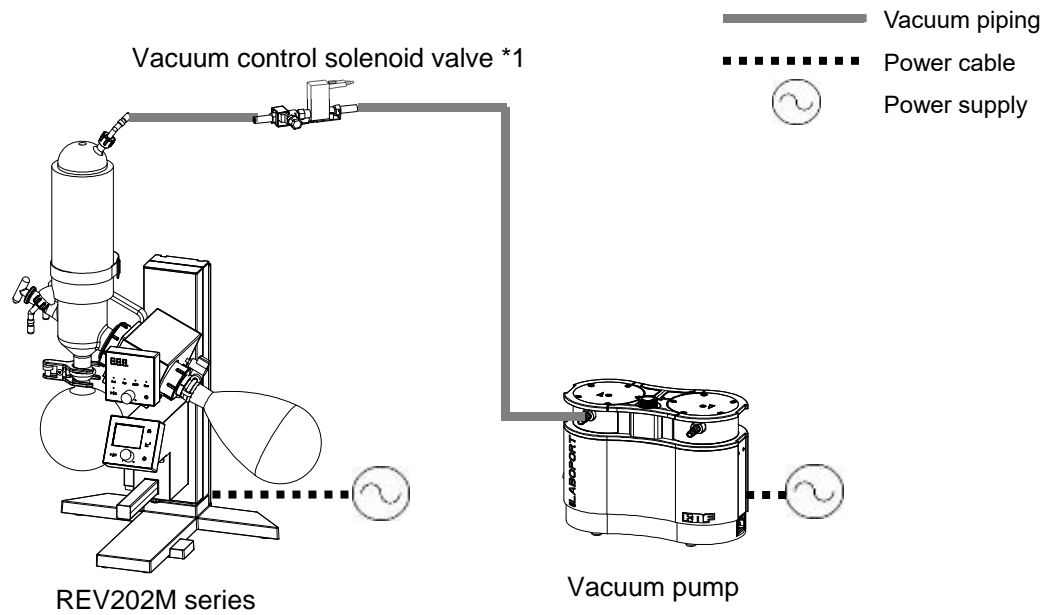

*1: Vacuum control solenoid valve is embedded in the back of main unit.

2. COMPONENT NAMES AND FUNCTIONS

Piping/Power System Diagram

B. When performing vacuum control by Vacuum pump control unit G and vacuum control solenoid valve.

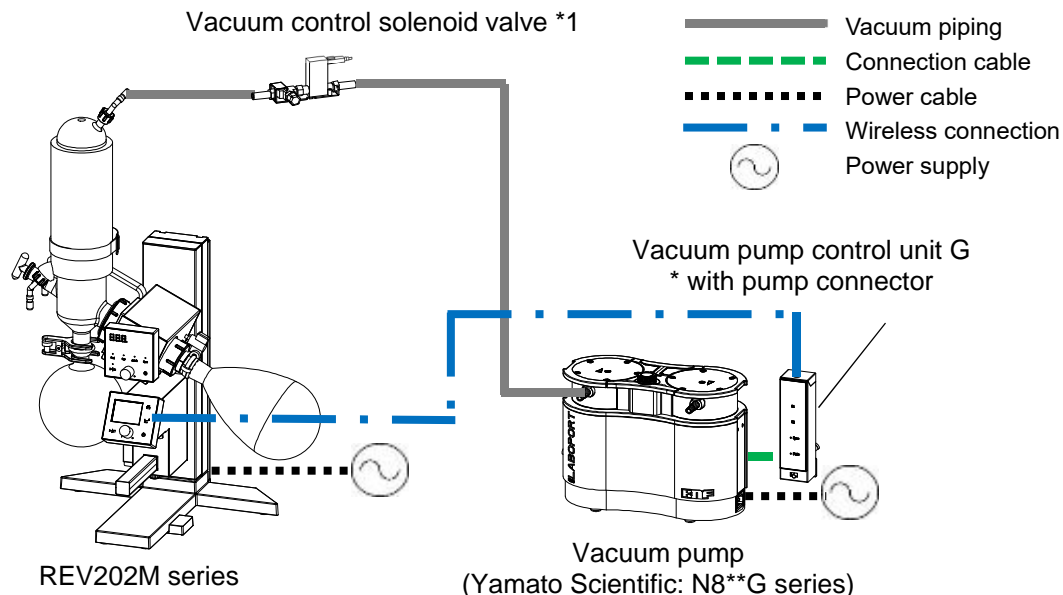

*1: Vacuum control solenoid valve is embedded in the back of main unit.

C. When performing vacuum control by Vacuum pump control unit and vacuum control solenoid valve.

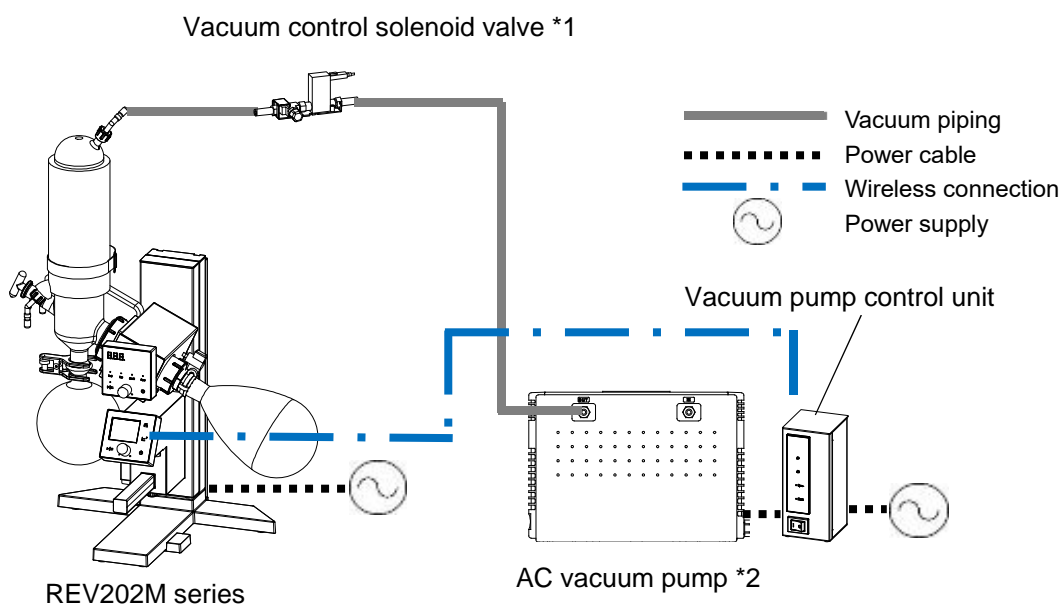

*1: Vacuum control solenoid valve is embedded in the back of main unit.

*2: Applicable AC pump: Yamato Scientific PG201, ULVAC DTC-22/DTC-41, KNF N810/N820/N840
REV202M-A, REV212M-A, REV212M-B, and REV212M-D cannot be connected with Vacuum pump control unit.

Where the condensed sample splashes from the exhaust port of vacuum pump, attach the waste liquid trap bottle included with Solvent recovery unit (RT302) or Stand (ORT10).

3. PRE-OPERATION PROCEDURES

Installation Precautions



Choose an appropriate installation site

DO NOT install unit:

- where installation surface is not completely level, not even or not clean.
- where flammable or corrosive gases/fumes may be present
- where external temperature will exceed 35 °C, will fall below 5 °C or will fluctuate largely.
- where liquid is assumed to splash on unit
- in excessively humid or dusty locations.
- in direct sunlight or outdoors.
- where there is constant vibration.
- in direct contact with the outside air
- where power supply is erratic.
- where there is combustible material nearby.
- in the proximity of, particularly right below a fire alarm.
- where there is a risk of freezing or condensation.



Install unit, including glass set, in a location with sufficient space as specified below.

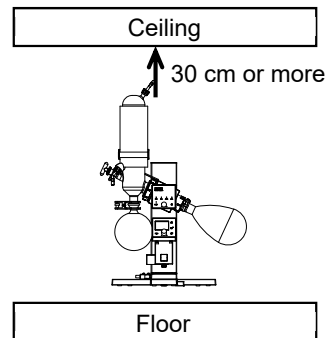
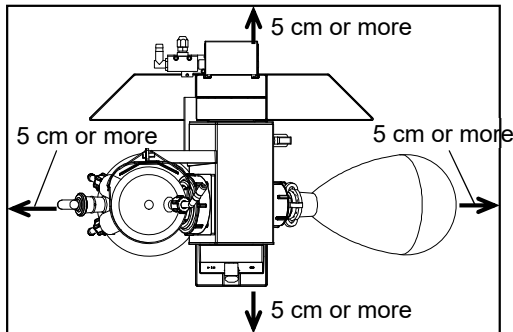

Install unit on a level surface

Install unit on a level and even surface. Failure to do so may cause abnormal vibrations or noise, possibly resulting in complications and/or malfunction.

Use level adjuster on the back of unit when unit still wobbles despite level installation.

Turn the wheel left to ascend, and turn it right to descend.

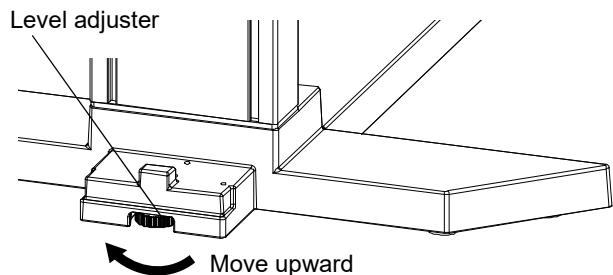

3. PRE-OPERATION PROCEDURES

Installation Precautions



Complete "Name setting" and "Password setting" before operating with the wireless interlock

When using the wireless interlock function, change the "Name" and "Password" according to instruction manual of each device. If there is a combination with the same name and password, radio may be cross-talked and may not work properly.



Keep the devices in the wireless communication within 10 m from each other

Communication may be interrupted if the devices are apart from each other more than 10 m, or if there is a wall or metal objects between the devices.

3. PRE-OPERATION PROCEDURES

Installation Precautions



Always connect power cable to appropriate facility outlet or terminal

Connect power cable to a suitable facility outlet or terminal, according to the electrical requirements.

Electrical requirements: 100-230 V AC Single phase 50/60 Hz 1 A or less
It is necessary to prepare appropriate power cable when using with the voltage other than 100 V AC.
Contact original dealer of purchase for assistance.

Operational voltage range is $\pm 10\%$ of power rating, performance guarantee voltage range is $\pm 5\%$, and frequency is $\pm 1\%$

* Check the line voltage on distribution board and properly evaluate whether to utilize a line being shared by other equipment. If unit is not activated by turning ON (I) power, take an appropriate course of action, such as connecting unit to a dedicated power source. Inserting multiple cords into a single outlet, using branch outlets or extension cords, may cause a drop in voltage, resulting in failure to control.



Install in a dry location

Install unit where it will be free from liquid spray and other moisture. Failure to do so may result in control mechanisms becoming wet, causing malfunction, electrical shock and/or fire.

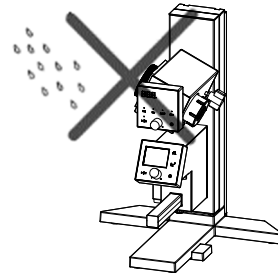

Pay attention to the surroundings whenever operating spring jack

Do not place any objects under the slide panel. Such objects may cause damage to unit or personal injury upon jack operation.

Always lower the slide panel slowly to prevent damage to glassware on contact with the bath.

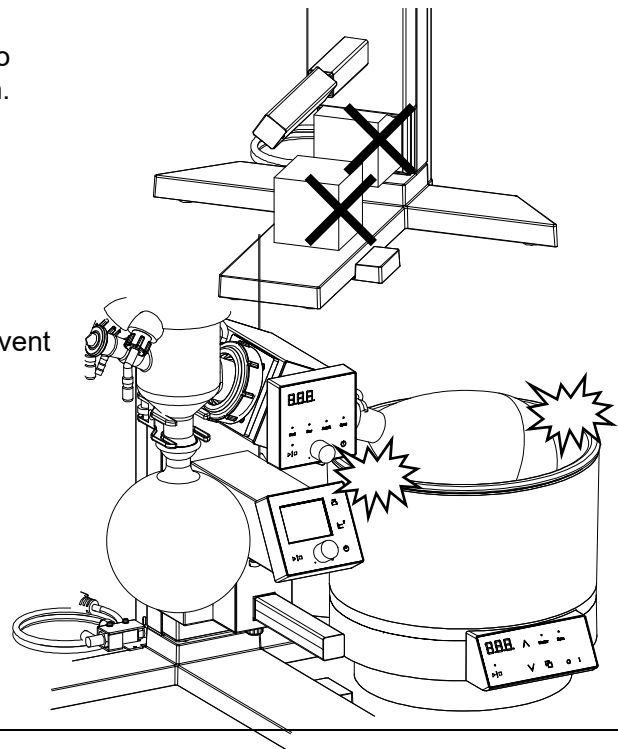

3. PRE-OPERATION PROCEDURES

Installation Procedure



Be aware that slide panel may spring up

Slide panel on this unit employs a spring-loaded jack to lift up. The spring tension is adjusted to achieve balance when all the connection with glassware and piping are made. The panel jumps up when releasing the lock of the jack without glassware mounted. Be sure to hold top of the slide panel by hand whenever releasing the lock.



Always install glassware and piping with the slide panel lifted up

If the lock of the jack is unintentionally released while setting up glassware and piping, there is a risk of damage to glassware, and/or personal injury. Always install glassware while slide panel is lifted up.

1. Jacking up

- (1) Release the lock by turning jack handle counterclockwise while holding the slide panel top.

* Hold the slide panel tightly or it may jump up.

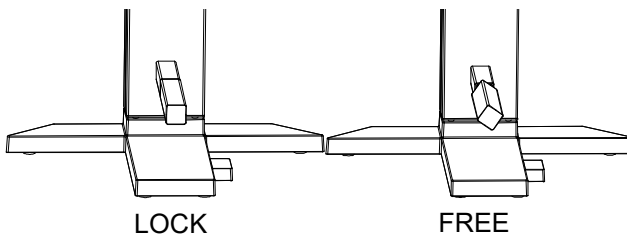

- (2) Lift up the slide panel to top, turn the handle clockwise to lock.

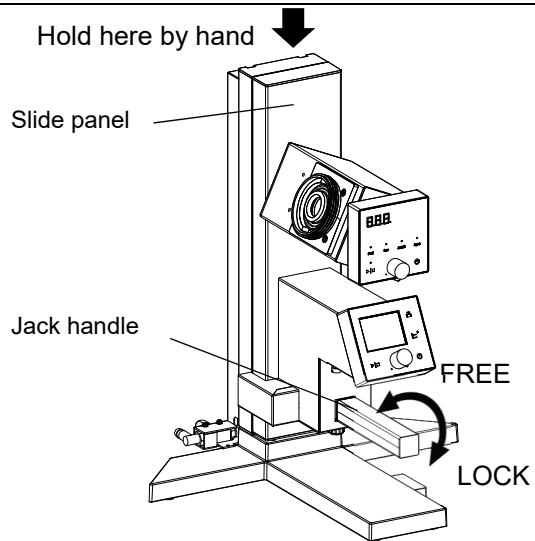

2. Motor box tilt adjustment (set in reverse position)

- (1) Hold motor box by hand, and turn tilt adjustment screw counterclockwise to release the lock.
- (2) Motor box can now rotate. Rotate the box to the position for use and turn tilt adjustment screw clockwise to lock the driving unit.
- (3) Adjust the control panel angle for better viewability.
- (4) Glassware can be set in the opposite direction by turning motor box clockwise (reverse position).

* Tilt the driving unit at about 30° before installation.

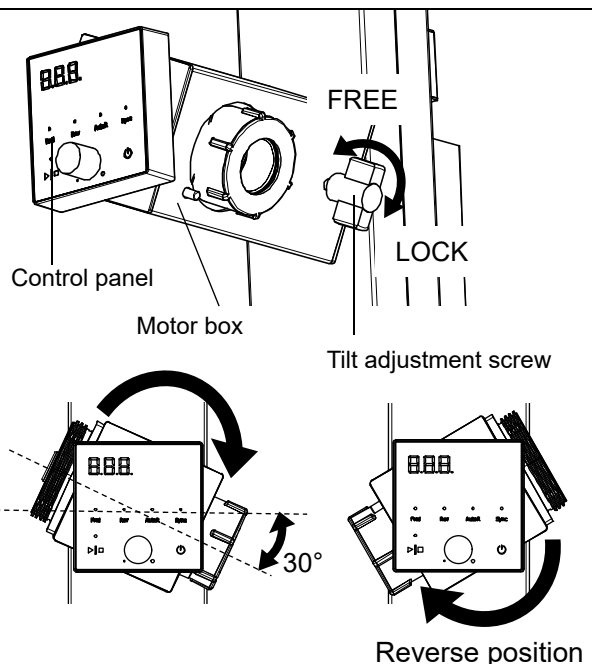

3. PRE-OPERATION PROCEDURES

Installation Procedure

3. Connecting power cable

(1) Hold AC adapter with the inlet facing the bottom left viewed from the back, and insert it into the AC adapter holder at an angle.

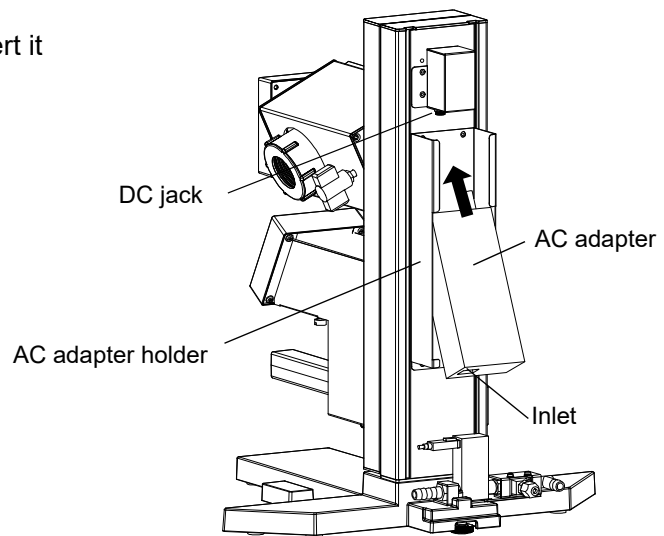

(2) Connect the plug from AC adapter to the DC jack. Use included tape fastener to bind excess cable to keep it in the holder.

(3) Insert power cable into the inlet of AC adapter.

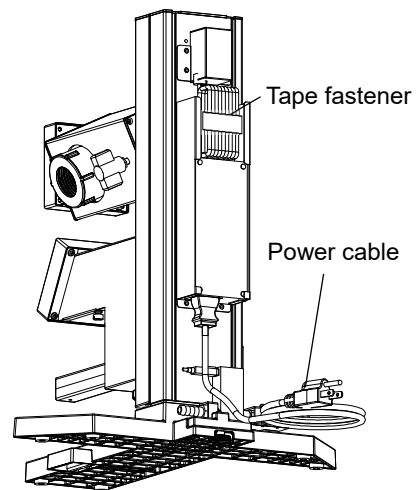

3. PRE-OPERATION PROCEDURES

Installation Procedure

4. Connecting cables and tubing

* Ensure that the tubing is not loose or disconnected.

- (1) Connect the PTFE tube protruding from the back of main unit to the fitting of the vacuum control solenoid valve, and connect connection cable, with the hook facing up, to the connector on the vacuum control solenoid valve.

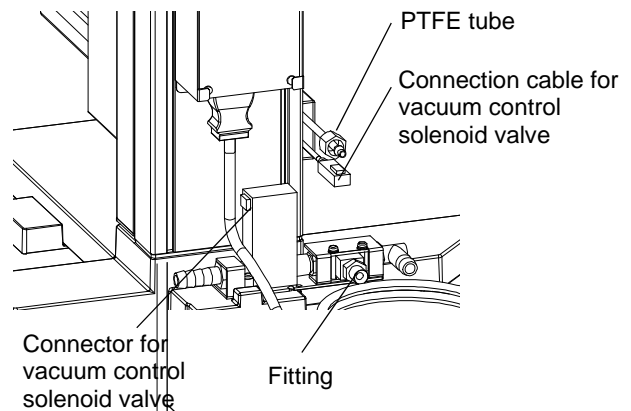

* The PTFE tube is used in combination with a nut and sleeve. Be careful with small parts so that they do not get lost.

Insert the PTFE tube straight into the fitting of the vacuum control solenoid valve, then tighten the nut firmly. Pull on the PTFE tube to make sure that it does not come off.

* Inserting the tube diagonally may deform the sleeve, leading to a vacuum leak.

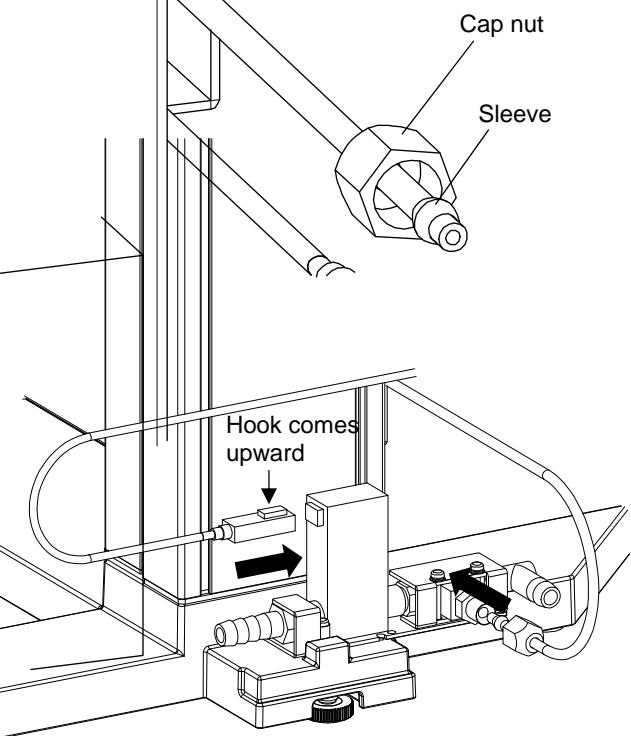

- (2) Connect Outlet of the vacuum control solenoid valve and the vacuum pump with a vacuum hose, and connect Inlet and the vacuum nozzle (gray) of the cooling condenser.

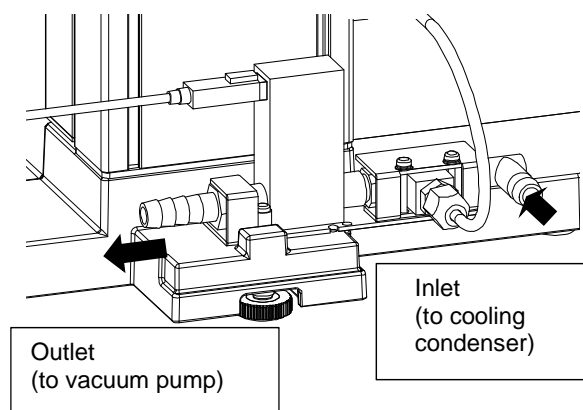

3. PRE-OPERATION PROCEDURES

Installation Procedure

4. Connecting cables and tubing

(3) Slide supplied rear cover over the post along its groove. Draw power cable and connection cable through the U-notch in the bottom of rear cover.

* Exercise caution not to pinch power cable, connection cable, and solenoid valve cable in the rear cover when attaching it.

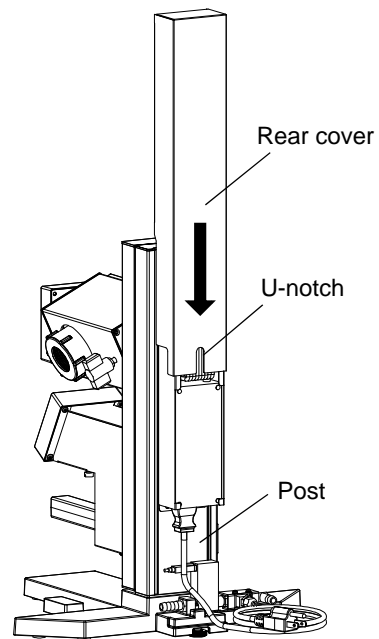

3. PRE-OPERATION PROCEDURES

Installation Procedure

5. Installing rotary joint

(1) Remove joint nut

Press in the lock pin with the thumb to lock the rotary part. Take off joint nut by turning it counterclockwise with the other hand.

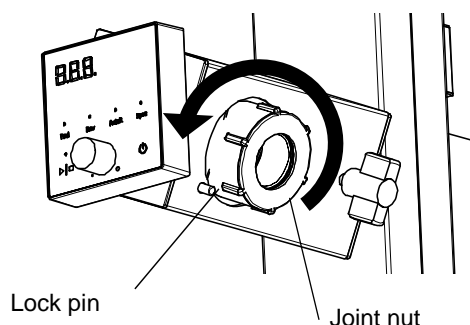

(2) Install rotary joint

Insert rotary joint into the rotary joint opening until it clicks, while holding motor box tightly with the other hand.

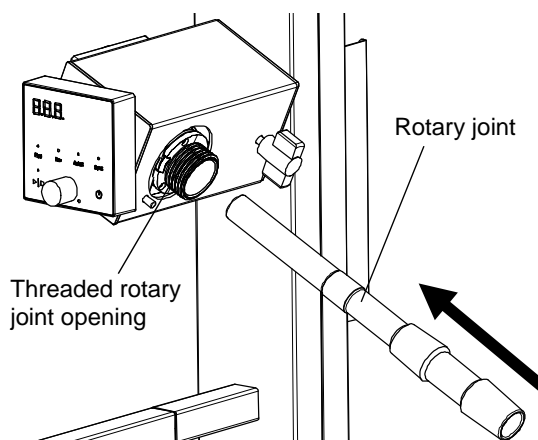

(3) Replace joint nut

As with the step (1), press in the lock pin to lock the rotary part. Screw in joint nut clockwise with the other hand.

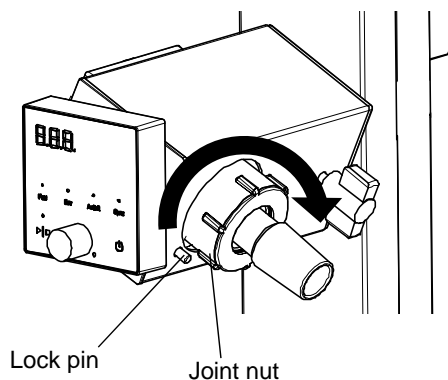

(4) Attach flask removal tool (included with glass set)

① Fit flask removal tool over rotary joint.

② Pinch flask removal tool and slip it in joint nut.

* There is a direction for flask removal tool.
Pawl should come to the joint nut side.

Flask removal tool facilitates removing flask and rotary joint. See "Operation Stop" (P.42)
Threaded rotary joint opening

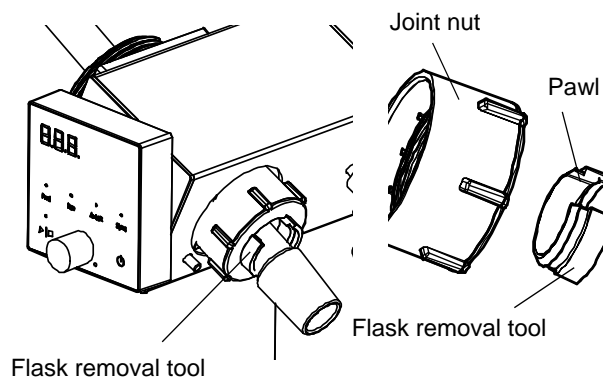

3. PRE-OPERATION PROCEDURES

Installation Procedure



Use caution when handling glassware

Any damage on glassware may lead to serious accidents. Check glassware for damage before operation.

6. Attaching condenser nut

Attach condenser nut for mounting condenser on main unit

- ① Pass condenser nut on condenser flange.
- ② Put coil ring over condenser flange.
- ③ Lightly pull on condenser nut to ensure it does not come off condenser flange.

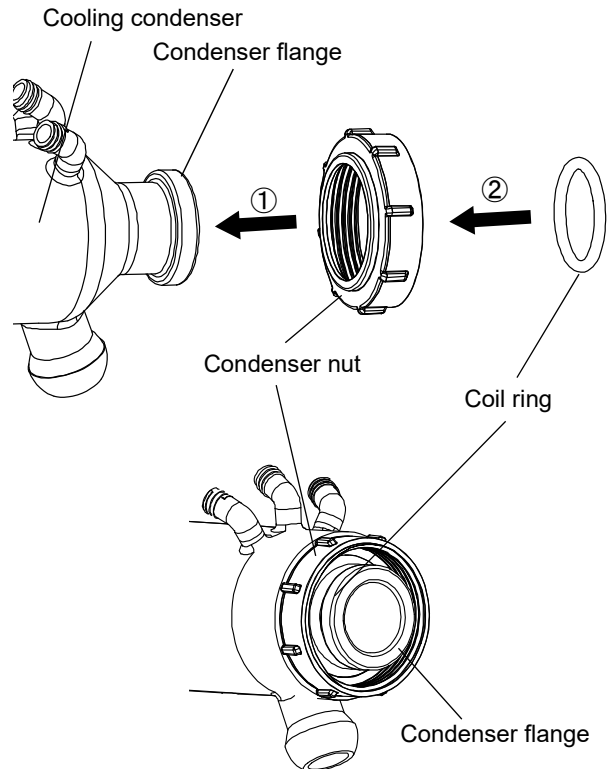

3. PRE-OPERATION PROCEDURES

Installation Procedure

7. Installing vacuum seal



Pay attention to the direction of vacuum seal.

Installing vacuum seal in the opposite direction may lead to rough vacuum, or may wear the seal, resulting in damage to driving unit.

(1) Installing vacuum seal

Fit vacuum seal into the housing by passing it on rotary joint with the side which spring is visible facing motor box.

* Be sure to install vacuum seal after rotary joint is set, to prevent damage to vacuum seal.

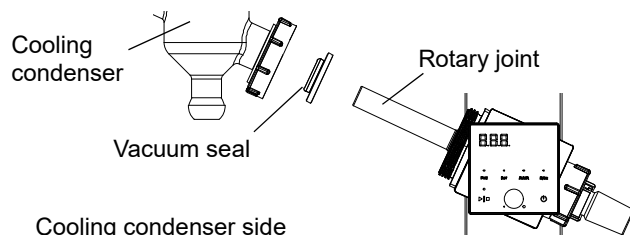
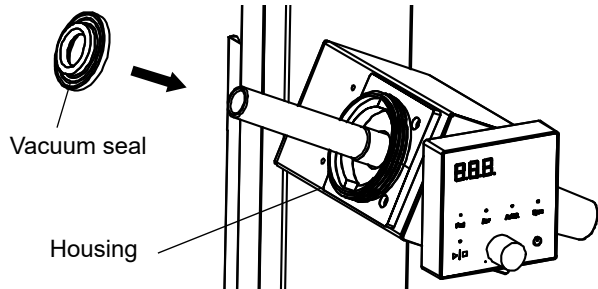

(2) Installing PTFE vacuum seal (Optional)

Fit PTFE vacuum seal into the housing by passing it on rotary joint with the side on which O-ring is visible facing the cooling condenser.

PTFE vacuum seal is made of firm material. Install it slowly without applying excessive force.

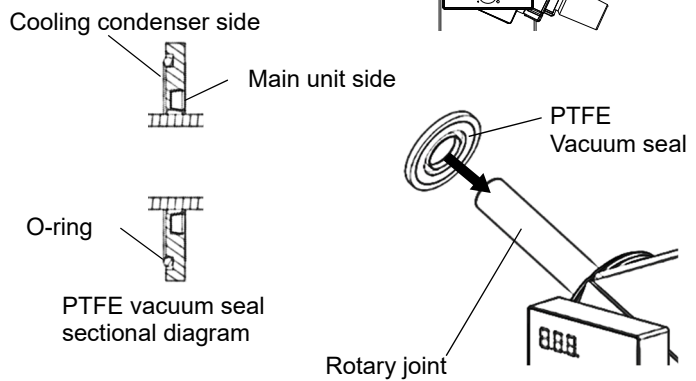

Make pipe connection properly

Be sure to install all pipes in right positions. Improper connection and looseness of nozzle caps may cause leakage or damage to peripherals.

8. Installing nozzle unit

* Nozzle unit has two types, with gray cap and with black cap.

Gray: for vacuum line
Black: for cooling water line

* Three parts of "Nozzle", "Nozzle cap", and "Nozzle gasket" comprise the nozzle unit.

Ensure that nozzle gasket is placed in nozzle cap.

- ① Screw down nozzle cap against nozzle receptacle on cooling condenser.
- ② Turn nozzle cap clockwise to fasten.

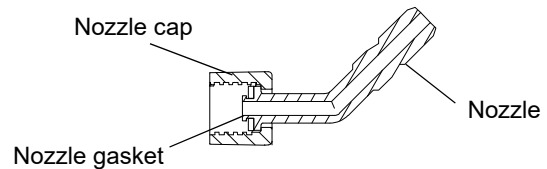

Nozzle unit sectional diagram

Attach vacuum nozzle onto center nozzle receptacle, and cooling nozzles onto receptacles on both sides

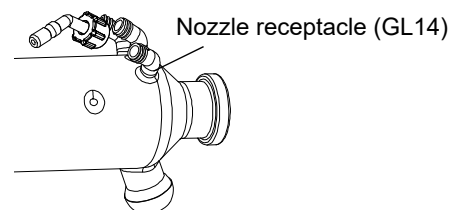

3. PRE-OPERATION PROCEDURES

Installation Procedure



Make pipe connection properly

Be sure to install all pipes in right positions. Improper connection and looseness of nozzle caps may cause leakage or damage to peripherals.

9. Installing one-touch cooling nozzle (optional, P.58)

* Three parts of "One-touch joint", "Adapter", and "Gasket" comprise the one-touch nozzle unit.

Ensure that gasket is placed in adapter.

- ① Screw down one-touch cooling nozzle against nozzle receptacle on cooling condenser.
- ② Turn one-touch cooling nozzle clockwise to fasten.
* When installing the nozzle, always grasp it by adapter. Failure to do so may loosen one-touch joint, resulting in water leakage.

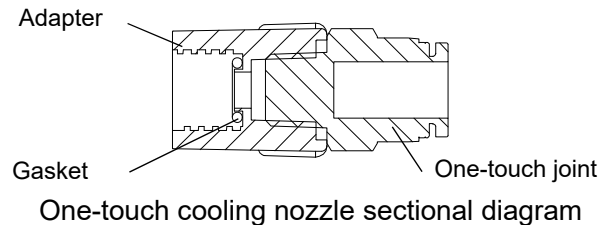

One-touch cooling nozzle sectional diagram

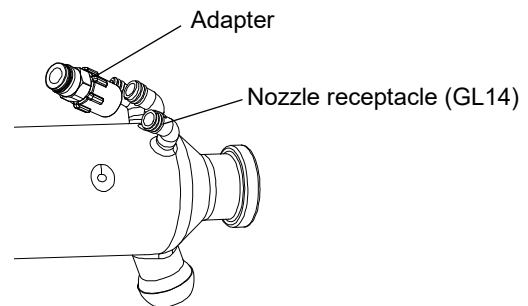

10. Installing bath guide

Attach supplied bath guide to main unit stand base.

- (1) Insert bath guide into a slot on bottom of stand base.
The bath guide slots are positioned on both right and left. Choose the side on which an evaporation flask is to be attached.

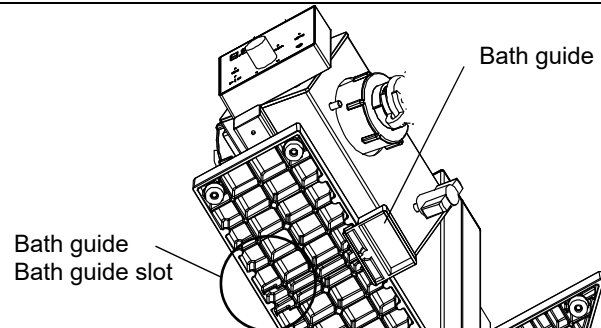

3. PRE-OPERATION PROCEDURES

Installation Procedure

11. Installing condenser bracket (only for vertical condenser, type B)

* Use vertical condenser (type B) in conjunction with condenser bracket included with glass set B.

- (1) Remove two cap bolts (black) on motor box with supplied hex wrench.

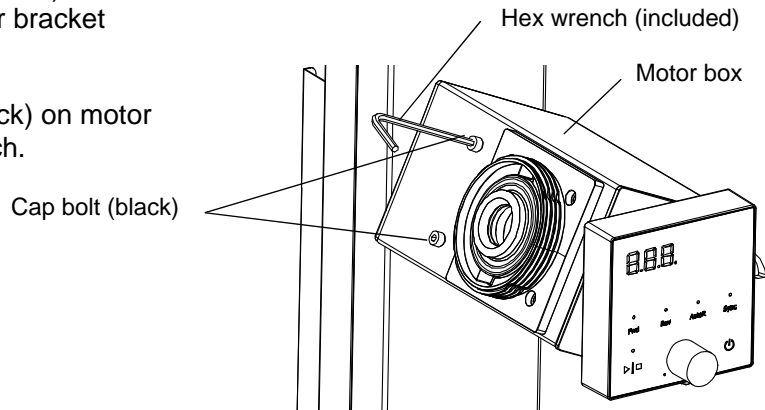

- (2) Attach condenser bracket with the removed cap bolts.

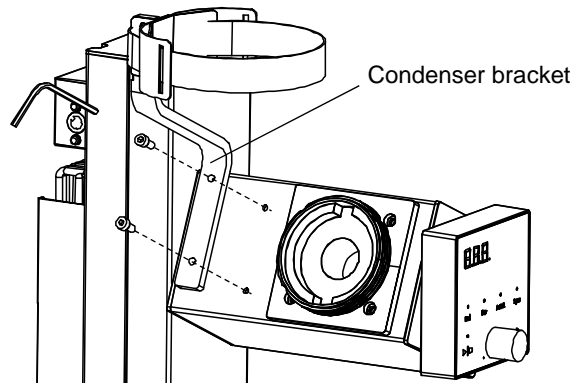

- (3) Reverse position

- ① Remove two cap bolts of condenser bracket with hex wrench
See the right figure to rearrange condenser support to the reverse direction.

- ② Adjust the angle of motor box and control panel, according to procedures in "Motor box tilt adjustment (set in reverse position)" (P.19)

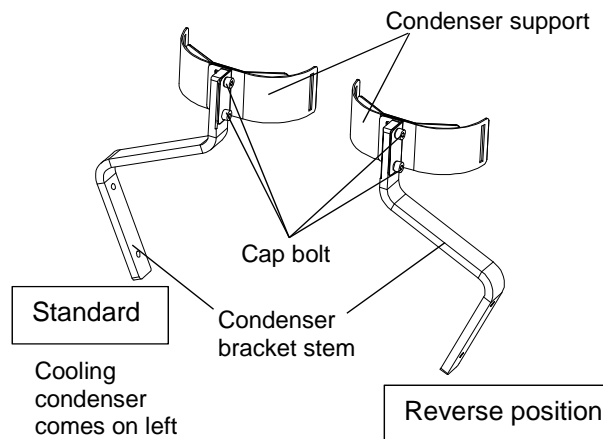

- ③ Remove cap bolts on motor box, and therewith fasten condenser bracket on the box (see right figure).

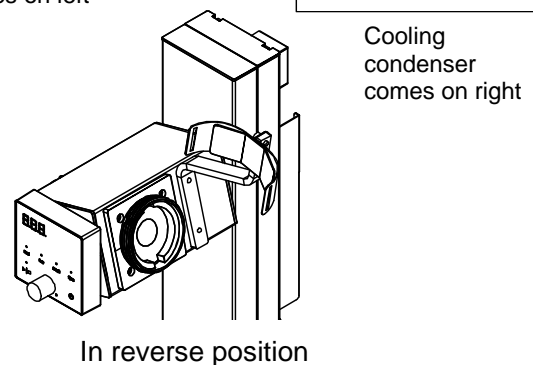

3. PRE-OPERATION PROCEDURES

Installation Procedure

12. Installing cooling condenser and flask



Install glassware while slide panel is lifted up.

If slide panel springs up during setting, glass breakage and/or personal injury may result. Be sure to hold down slide panel top when unlocking the jack.

[Glass set A]

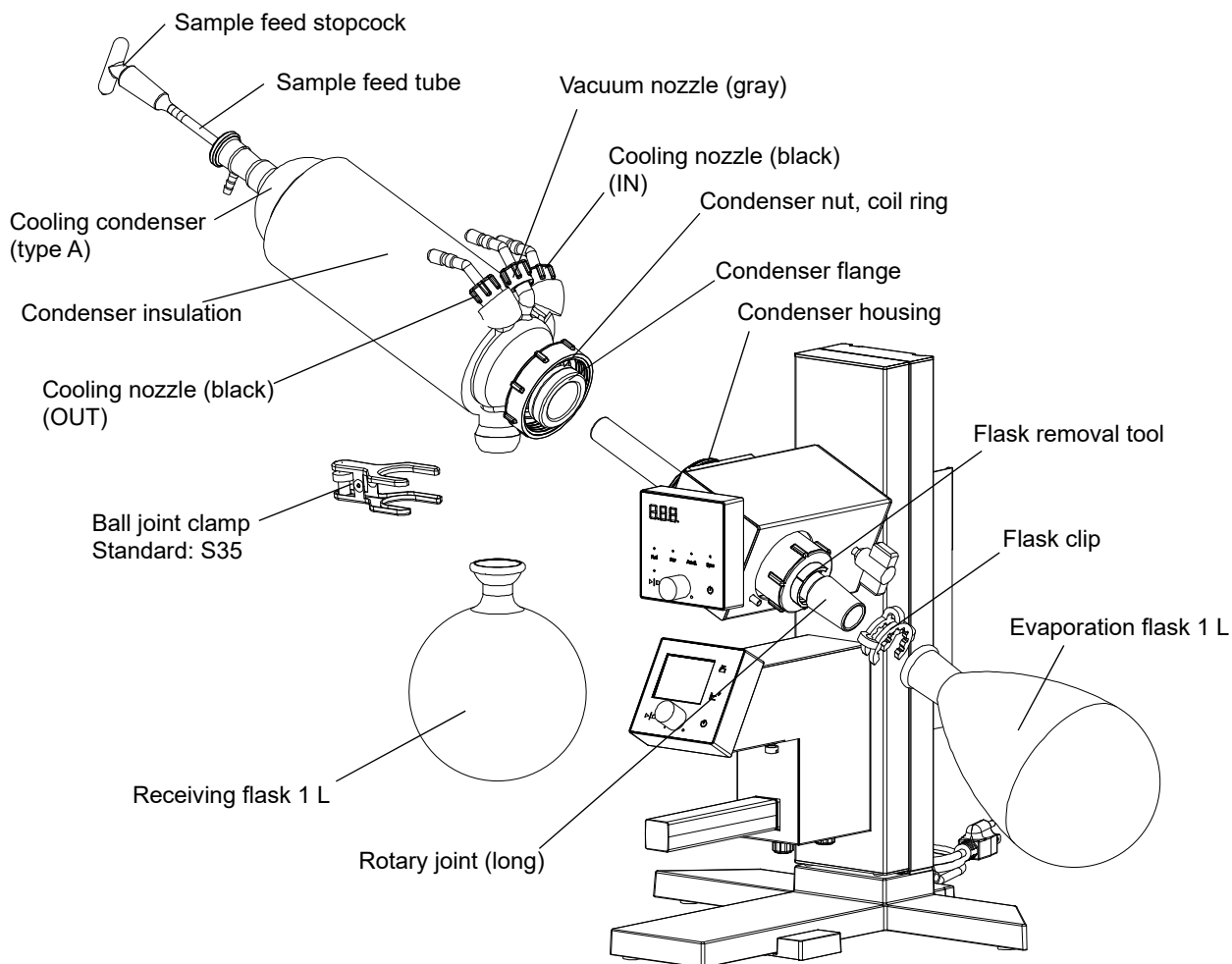

- (1) Bring condenser flange into intimate contact with vacuum seal in condenser housing, and tighten condenser nut clockwise to some extent. Turn the condenser and the nut simultaneously to re-tighten. Ensure that the joint for receiving flask faces down.
- (2) Slide condenser insulation over the condenser.
- (3) Attach receiving flask to cooling condenser with ball joint clamp.

- (4) Put evaporation flask on rotary joint and secure it with flask clip.

- (5) Insert sample feed stopcock carefully into the condenser so that sample feed tube does not become bent or twisted.

3. PRE-OPERATION PROCEDURES

Installation Procedure

12. Installing cooling condenser and flask



Install glassware while slide panel is lifted up.

If slide panel springs up during setting, glass breakage and/or personal injury may result. Be sure to hold down slide panel top when unlocking the jack.

[Glass set B]

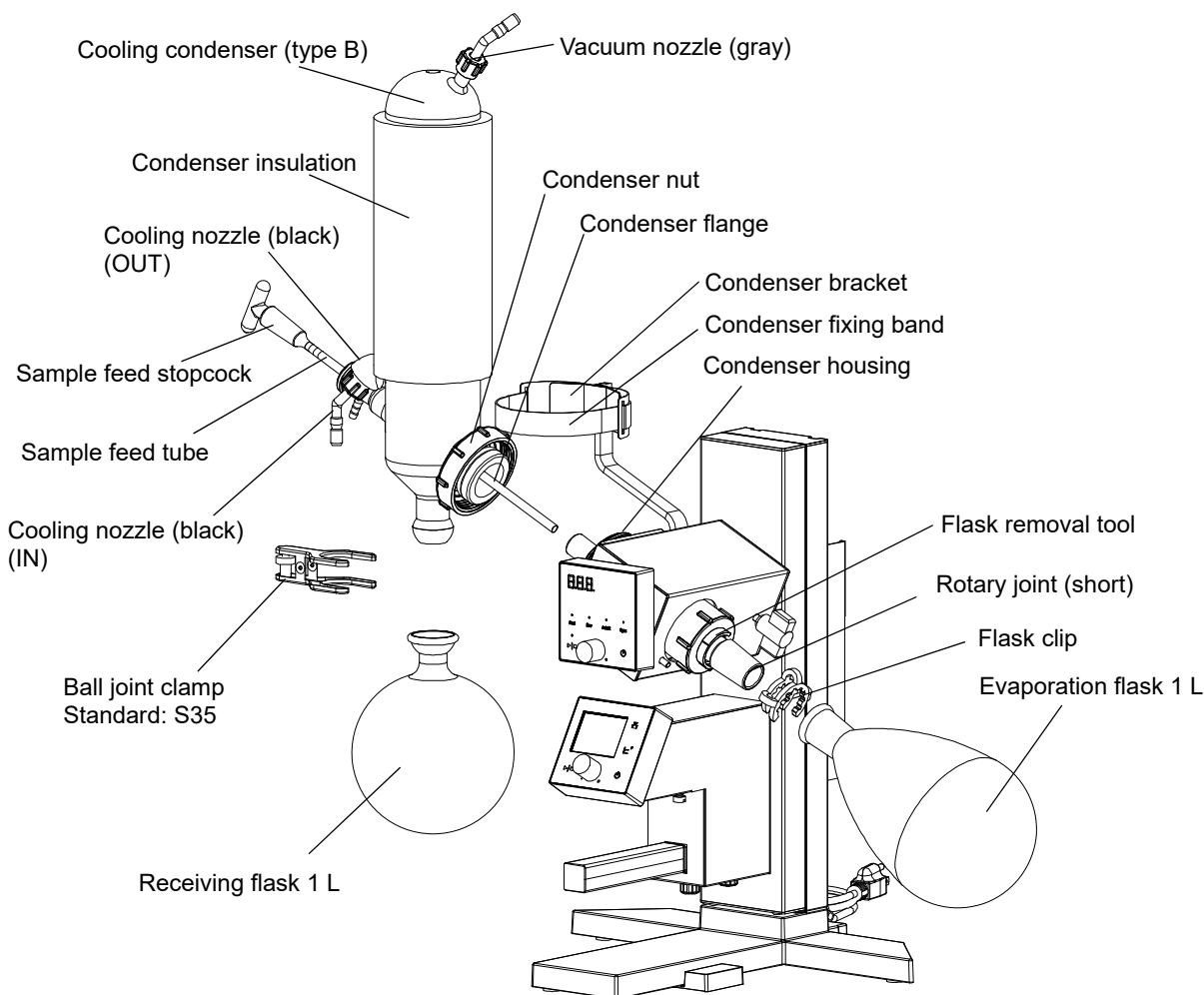

- (1) Attach condenser bracket. (P.27)
- (2) Bring condenser flange into intimate contact with vacuum seal in condenser housing, and tighten condenser nut clockwise to some extent. Turn cooling condenser and the nut simultaneously to re-tighten. Ensure that the joint for receiving flask faces down.
- (3) Slide condenser insulation over the condenser.
- (4) Pull out one end of condenser fixing band from the buckle, and put the condenser onto condenser bracket. Pass the fixing band through the buckle, and pull on the both sides to fasten the condenser. (see right figure)
- (5) Attach receiving flask to the condenser with ball joint clamp.
- (6) Put evaporation flask on rotary joint and secure it with flask clip.
- (7) Insert sample feed stopcock carefully into the condenser so that sample feed tube does not become bent or twisted.

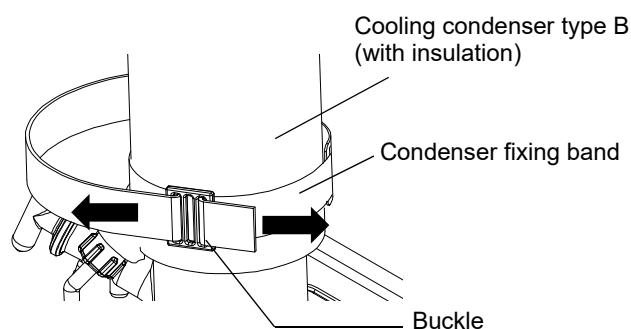

3. PRE-OPERATION PROCEDURES

Installation Procedure

13. Connecting vacuum/cooling hose

* Vacuum hose is not included. Please prepare optional vacuum hose (product code: 255297) separately.

- (1) Connect vacuum nozzle and the inlet of a pressure reducing device with a vacuum hose.
 - * Be cautious not to connect vacuum nozzle to the exhaust port of the pressure reducing device. Doing so may cause RE unit to be pressurized, resulting in equipment malfunction.
- (2) Connect cooling nozzles and the circulation ports of a cooling water circulator.
 - * Be sure to attach the hose to cooling nozzle before threading it onto cooling condenser. Using excessive force may damage glassware.

[Cooling condenser type A] [Cooling condenser type B]

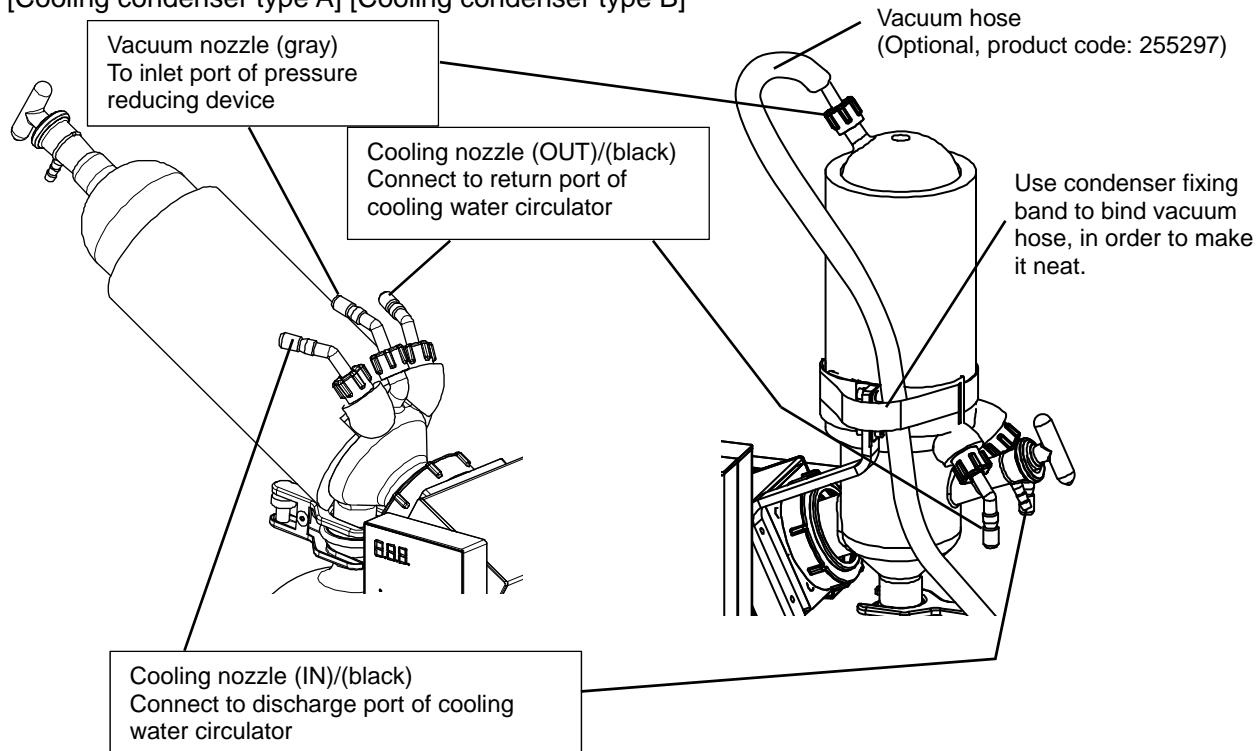

(3) One-touch cooling nozzle (optional)

① Attach one-touch cooling nozzle onto cooling condenser, and then insert rigid tube firmly into the condenser. Put supplied insert sleeve into rigid tube to prevent leakage.

② To remove the tube, pull it out while pressing in the collet of one-touch cooling nozzle.

* Press the whole surface of the collet evenly so that the tube can be easily removed.

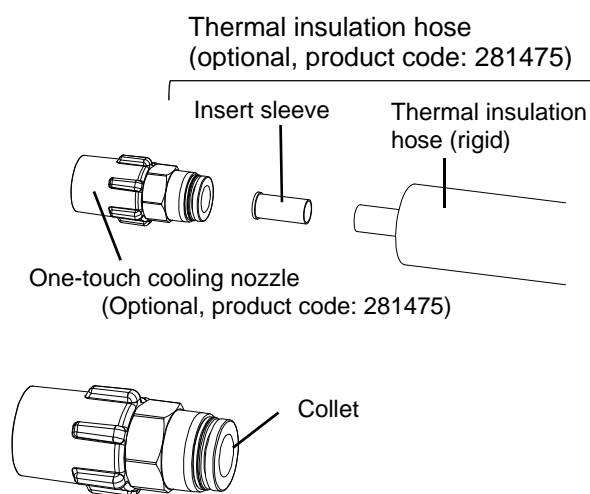

3. PRE-OPERATION PROCEDURES

Installation Procedure

14. Purge hose connection

* The purge hose is for purging unit by the vacuum controller with a gas instead of air. Not required when purging with air.

(1) Remove two knurled screws (large) on the bottom of the VR attachment bracket, and pull out the bracket from the handle.

* If the wiring or piping hinders pulling out the VR attachment bracket, see Step (2) below and pull out the vacuum controller first.

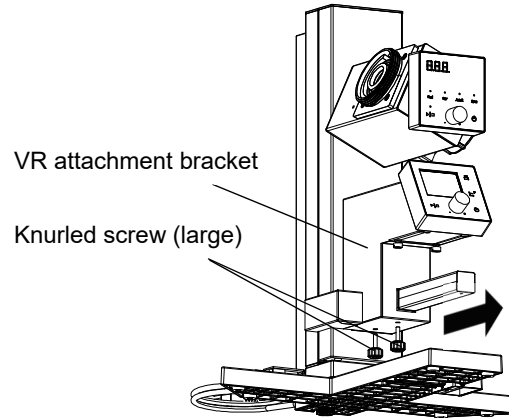

(2) Remove two knurled screws (small) on the bottom of the vacuum controller, and pull out the controller.

* Use caution not to apply stress on the connection cable.

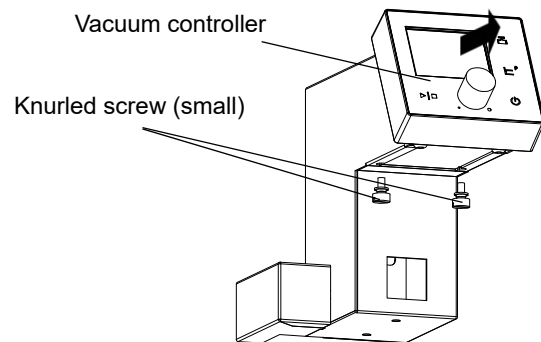

(3) Connect the attached exhaust hose to the leak port on the back of the vacuum controller, and route it inside the VR attachment bracket in the same way as the connection cable and PTFE tube.

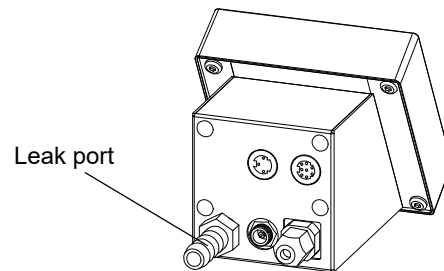

(4) Install the vacuum controller in the reverse procedure. When installing the VR attachment bracket, pull out the cable and piping from the cable port. Be careful not to pinch them with the bracket.

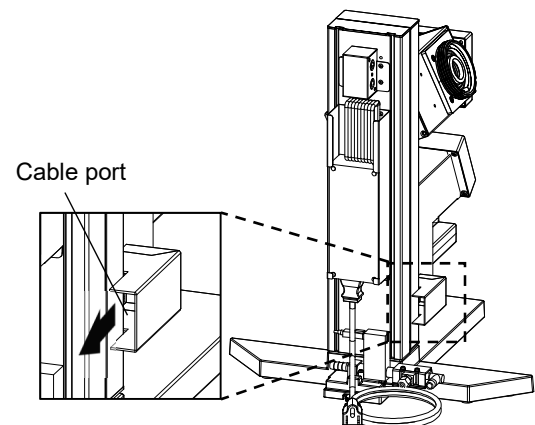

3. PRE-OPERATION PROCEDURES

Installation Procedure

15. Connection of rotary evaporator and vacuum controller

* The vacuum controller is connected at the time of shipment. If interlock function does not work, or any other symptoms occur, refer to this instructions to rework the connection.

This product is comprised of rotary evaporator and vacuum controller, connected with a connection cable, and can perform the following interlocking operation.

·Run/Stop interlocking

Starting vacuum control and rotation on either the rotary evaporator or vacuum controller will start the other device, and stopping either operation stops the other.

·Abnormal stop interlocking

When an error occurs, both devices will stop operation.

- ① Connect the L-terminal of the connection cable to the miniDIN connector of the rotary evaporator. Let the cable hang down.

VR connection terminal
miniDIN (8pin)

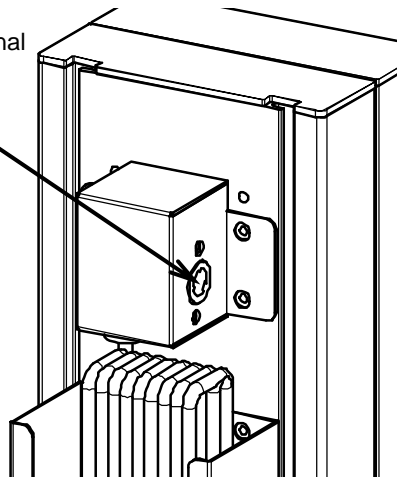

Connection cable
(included)
(L-terminal)

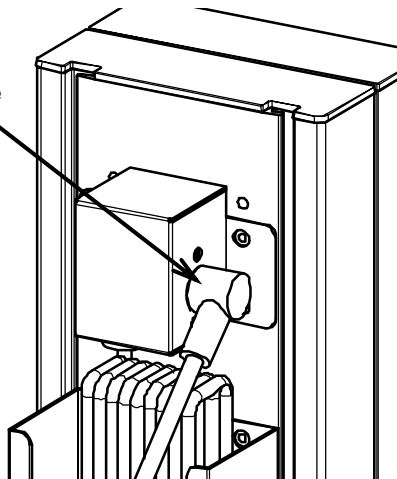

4. OPERATION PROCEDURES

Operation Procedure

[Control panel 1]

<p>1. Turn power ON</p>		<p>① Press the Power key. RPM display: shows software version at start up, then shows current rpm.</p> <p>Indicator lamp: One of the Fwd/Rev/AutoR lamps illuminates according to operation mode at the time of last power OFF (○).</p>
<p>2. Set rotation speed</p>		<p>① Press the Control knob. RPM display: Shows speed setting, flashing.</p> <p>② Set desired speed by turning the Control knob. Speed setting range: 5-315 rpm Turning the Control knob slowly increases or decreases the value by 1, turning it quickly changes the value by 10.</p> <p>③ Press the Control knob to finalize. RPM display: Shows current rpm. * ✨ indicates flashing.</p>

[Control panel 2]

<p>3. Turn power ON</p>	<p>Press the Power key. Yamato logo will show in the display for a few seconds, then moves to standby screen.</p>		
	<p style="text-align: center;">Yamato logo</p>		<p style="text-align: center;">Standby screen</p>
<p>4. Set the pressure</p>		<p>① Press the Control knob. Setting value flashes.</p> <p>② Set desired pressure by turning the Control knob.</p> <p>③ Press the Control knob to finalize. The setting value stops flashing.</p>	

4. OPERATION PROCEDURES

Operation Procedure

5. Start operation

[Start with the control panel 1]

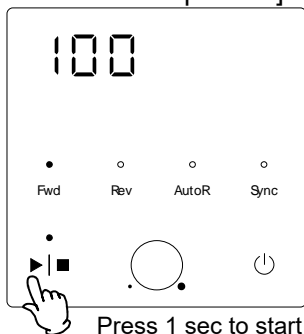

[Start with the control panel 2]

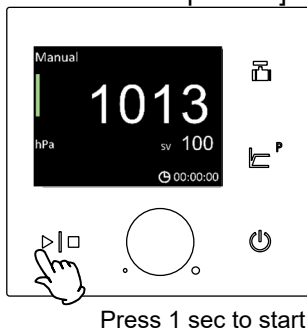

Operation can be started and stopped from both the control panel 1 and the control panel 2.

Press and hold ▶|■ for one second.

Run/Stop lamp : ON

<To stop>

Press ▶|■ again.

Run/Stop lamp : OFF

* Speed setting can also be changed during operation.

Indication at the top of screen and the color of the status bar differ by the operation mode.

Constant : Green, Gradient : Blue, Auto: Purple

* **The pressure setting can be changed during operation (after stabilized for Gradient and Auto modes).**

<To stop>

Press ▶|■ again.

* **Operation can start or stop while changing the pressure setting.**

Pressure setting will be finalized with the value at that point.

Regardless of which device stops the operation, unit automatically shifts to leak operation (where Auto leak is set to On) and cleaning operation (where Auto cleaning is set to On).





* See VR102S instruction manual for detailed instruction on the control panel 2.

4. OPERATION PROCEDURES

User Setting (Control Panel 1)

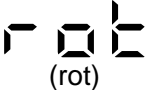
List of user setting items

- Press and hold the Control knob for two seconds. User setting items will be shown. Select an item by turning the Control knob. Press the Control knob again to edit the displayed item.
- Holding down the Control knob for two seconds while the user setting item is displayed, or leaving unit without key operation for about two minutes, will discard the changes, and the display returns to previous screen.
- It is not possible to enter user setting mode during operation.

Panel item	Description	Page
Rotation modes 	Rotation mode can be selected. F.ro: Forward rotation mode r.ro: Reverse rotation mode Ato: Timed auto inversion mode Auto inversion mode repeatedly changes rotation direction between forward and reverse, in accordance with time setting "SEC". (Default setting is "F.ro")	P.36
Auto inversion time setting 	Time interval for auto inversion mode can be set. Setting range: 5-999 (Default setting is "5")	P.37
Auto-resume function 	Select operation for the time power is restored. OFF: Unit goes into idle at power recovery. ON: Unit automatically reverts to status just before power loss and begin operation once again from that point. (Default setting is "Off")	P.38
LED brightness setting 	Change the LED brightness of the control panel. The brightness can be set in 8 levels from 0 to 7. Setting range: 0 to 7 (default setting: 3)	P.39
Vacuum controller connection 	Communication settings for vacuum controller VR102S can be made. OFF: Not linked (does not carry out communication) ON: Linked (carries out communication) While connection is "ON", operation start/stop on RE unit and vacuum controller are interlocked. Default setting is "ON"	P.40

4. OPERATION PROCEDURES

Rotation Mode (Control Panel 1)

Set rotation direction
 F.ro: Forward rotation mode
 r.ro: Reverse rotation mode
 Ato: Timed auto inversion mode
 Default setting is "F.ro"

1. Enter user setting

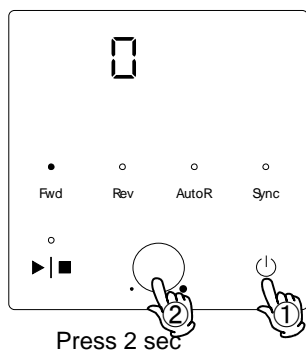

- ① Press the Power key.
- ② Press the Control knob for two seconds while current rpm is on the screen. Unit enters user setting.

2. Change rotation mode

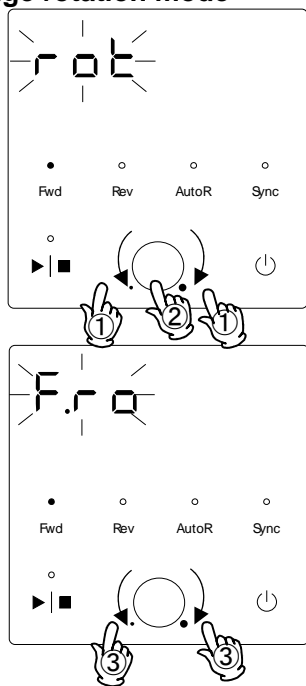

- ① Turn the Control knob and select "rot". RPM display: "rot" flashes
- ② Press the Control knob. RPM display: Current setting flashes
 F.ro: Forward rotation mode
 r.ro: Reverse rotation mode
 Ato: Timed auto inversion mode
- ③ Turn the Control knob to select rotation mode
- ④ Press the Control knob to finalize. A corresponding lamp among Fwd/Rev/AutoR lamps illuminates

* When operating RE unit in reverse position (bath comes on left), reverse rotation mode can prevent evaporation flask from scattering bath fluid toward the front by its rotation.

3. Exit user setting

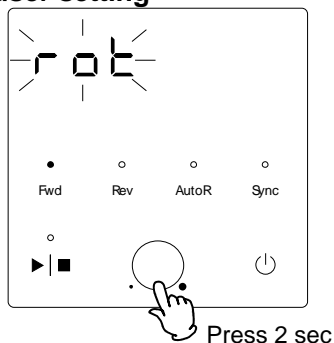

After completing the setting, press the Control knob for two seconds. Display reverts to previous screen and shows current rpm.

4. OPERATION PROCEDURES

Auto Inversion Time Setting (Control Panel 1)

Set time interval for auto inversion mode.

Setting range: 5-999 sec

Default setting is "5"

1. Enter user setting

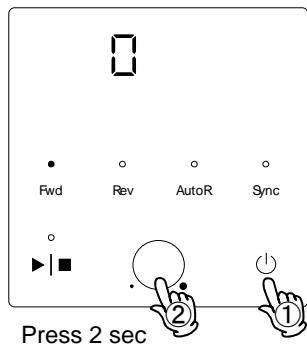

- ① Press the Power key.
- ② Press the Control knob for two seconds while current rpm is on the screen.

Unit enters user setting.

2. Change auto inversion time setting

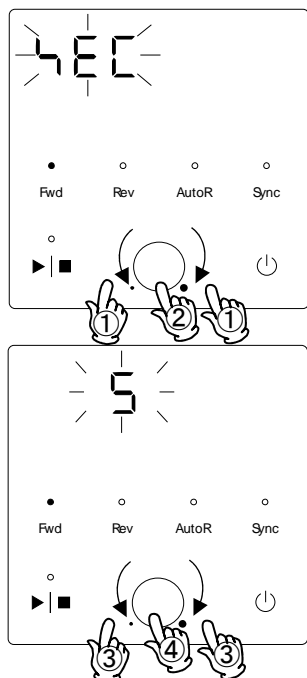

- ① Turn the Control knob and select "SEC".
RPM display: "SEC" flashes
- ② Press the Control knob.
RPM display: Current setting flashes
- ③ Turn the Control knob to select desired setting.
Setting range: 5-999 sec
- ④ Press the Control knob to finalize.

3. Exit user setting

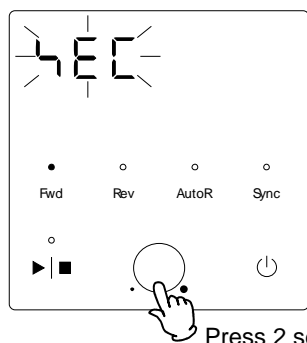

After completing the setting, press the Control knob for two seconds. Display reverts to previous screen and shows current rpm.

4. OPERATION PROCEDURES

Auto-resume Function (Control Panel 1)

Select recovery mode for the event of a power failure.

OFF: Unit goes into idle at power recovery.

ON: Unit automatically reverts to status just before power loss and begin operation once again from that point.

Default setting is "OFF"

1 Enter user setting

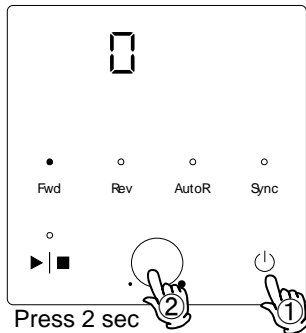

- ① Press the Power key.
- ② Press the Control knob for two seconds while current rpm is on the screen. Unit enters user setting.

2 Change the Auto-resume setting

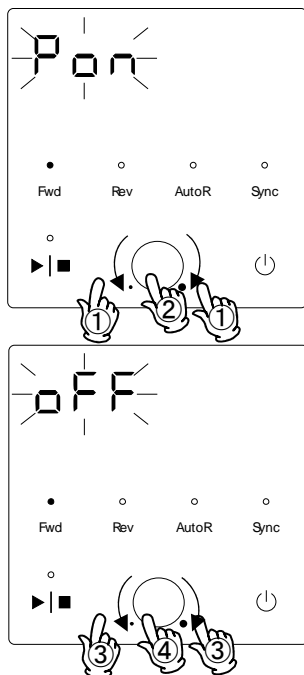

- ① Turn the Control knob and select "Pon". RPM display: "Pon" flashes
- ② Press the Control knob. RPM display: Current setting flashes
- ③ Turn the Control knob to select desired setting.
- ④ Press the Control knob to finalize.

3 Exit user setting

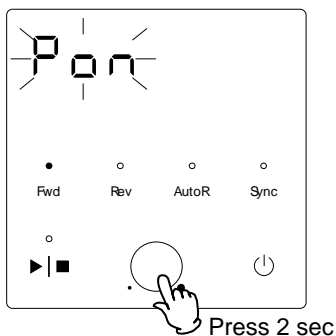

After completing the setting, press the Control knob for two seconds. Display reverts to previous screen and shows current rpm.

4. OPERATION PROCEDURES

LED Brightness Setting (Control Panel 1)

Change the LED brightness of the control panel.
The brightness can be set in 8 levels from 0 to 7.
Default setting is "3"

1 Enter user setting

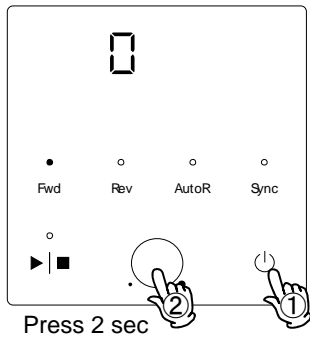

- ① Turn ON (I) power
- ② Press the Control knob for two seconds while current rpm is on screen.

Unit enters user setting.

2 Select the LED brightness level

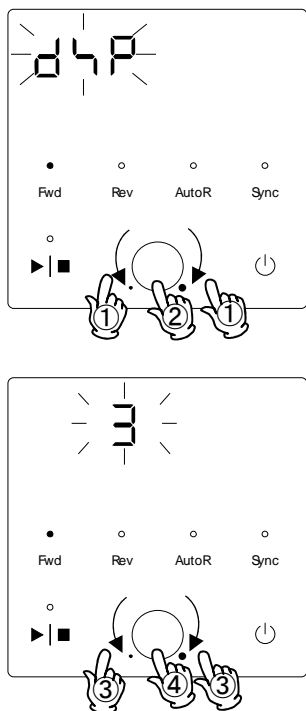

- ① Turn the Control knob and select "dSP".
RPM display: "dSP" flashes
- ② Press the Control knob.
RPM display: Current setting flashes
- ③ Turn the Control knob to select desired setting.
0 (dim) ⇔ 7 (bright)
- ④ Press the Control knob to finalize.

3 Exit user setting

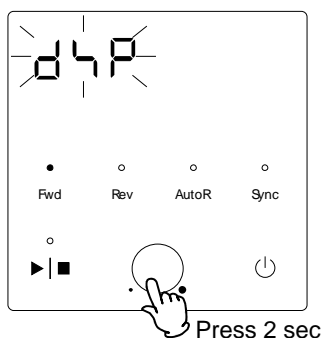

After completing the setting, press the Control knob for two seconds. Display reverts to previous screen and shows current rpm.

4. OPERATION PROCEDURES

Vacuum Controller Connection (Control Panel 1)

Make connection setting with vacuum controller.

OFF: Not linked (does not carry out communication)

ON: Linked (carries out communication)

Default setting is "ON"

While connection is "ON", operation start/stop on RE unit and vacuum controller are interlocked.

1 Enter user setting

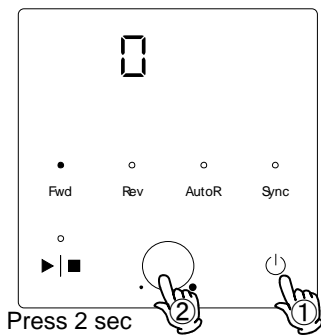

- ① Turn ON (I) power
- ② Press the Control knob for two seconds while current rpm is on the screen. Unit enters user setting.

2 Change connection setting

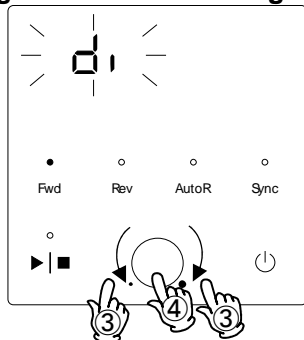

- ① Turn the Control knob and select "di". RPM display: "di" flashes

- ② Press the Control knob. RPM display: Current setting flashes

- ③ Turn the Control knob to select desired setting.

- ④ Press the Control knob to finalize.

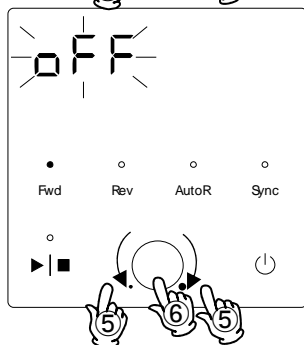

3 Exit user setting

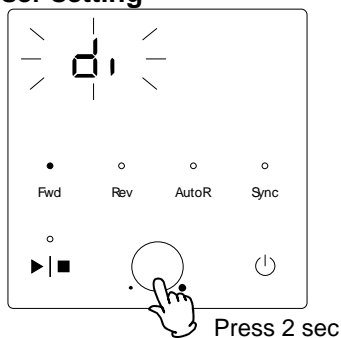

After completing the setting, press the Control knob for two seconds. Display reverts to previous screen and shows current rpm.

4. OPERATION PROCEDURES

Start Operation

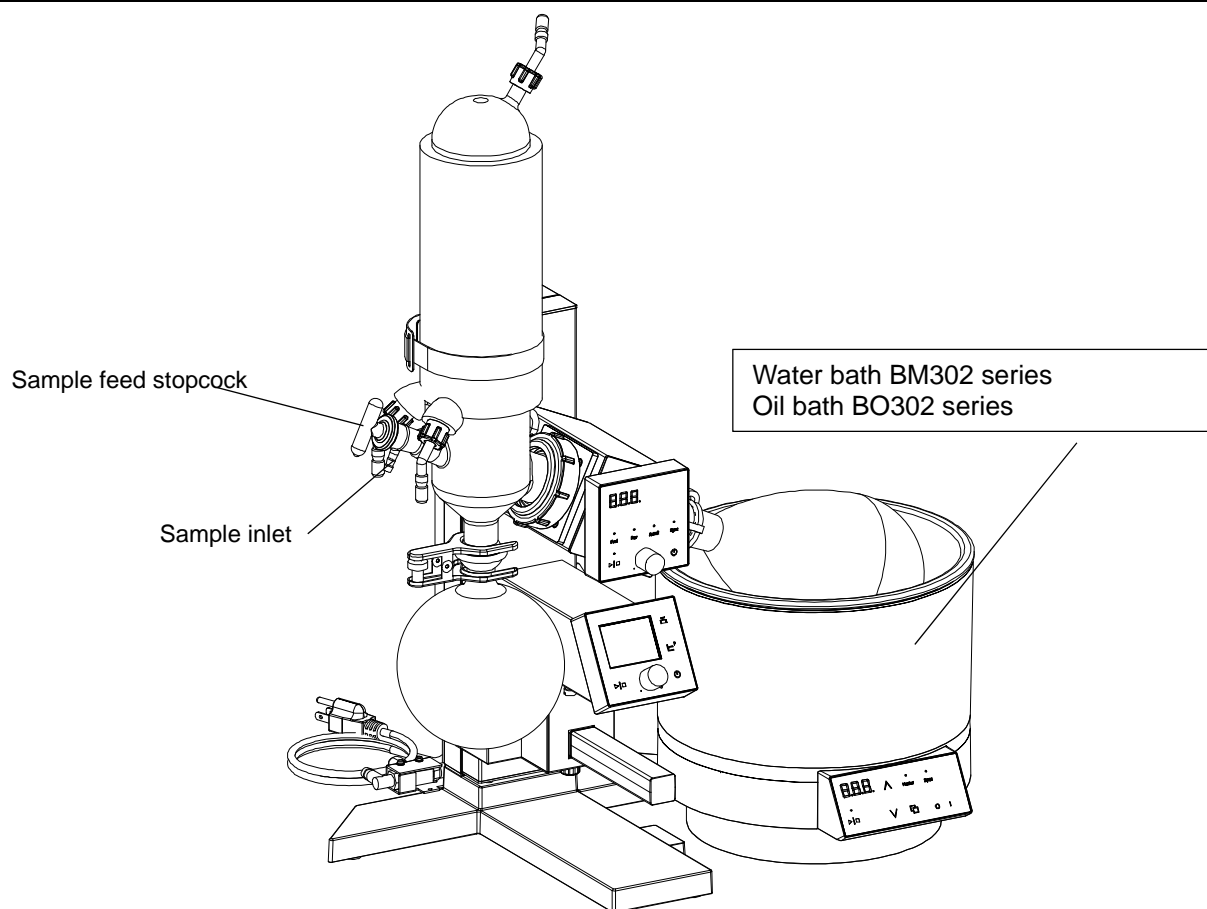

- (1) Run water bath, oil bath, or cooling water circulator at desired temperature.
- (2) Turn ON the control panels 1 and 2.
- (3) Rotate sample feed stopcock to close sample inlet. (The colored mark on stopcock comes to the front)
- (4) Sample liquid may be fed as follows. The procedure differs by the way of sample feed.

(4-A) Where samples are continuously fed by sample feed tube.

- ① Connect sample inlet and sample container with sample feed tube.
- ② Lower slide panel gently to immerse evaporation flask in the bath.
* Do not let the bath fluid overflow.
- ③ Start operation with the Run/Stop keys on the control panel 1 or control panel 2.
- ④ Rotate sample feed stopcock slowly so that the yellow mark on the stopcock faces down. Sample liquid is drawn into the flask.
* Feeding sample rapidly may bump the liquid. Rotate the stopcock slowly to avoid a loss of sample, and other complications.

(4-B) Where samples are not continuously fed (manually added)

- ① Detach evaporation flask and pour sample liquid directly in it, then re-attach the flask to rotary joint.
- ② Lower slide panel gently to immerse evaporation flask in the bath.
* Do not let the bath fluid overflow.
- ③ Start operation with the Run/Stop keys on the control panel 1 or control panel 2.

4. OPERATION PROCEDURES

Operation Stop

- (1) Press the Run/Stop key on the control panel 1 or control panel 2 to stop rotation and decompression.
When auto leak function of the vacuum controller is turned on, the leak valve will open.
When auto cleaning is enabled, cleaning will start after the preset time for auto leak function.
(When auto leak function is turned off, use the stopcock or the leak key on the vacuum controller to open to the atmosphere.)
- (2) Turn jack handle counterclockwise to release the jack. Lift slide panel slowly so that evaporation flask comes out of the bath.

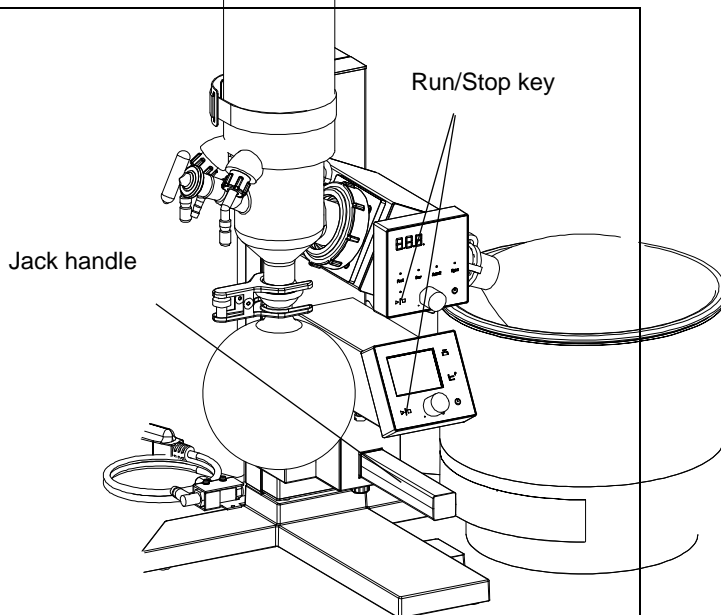

- (3) Remove flask clip from evaporation flask.

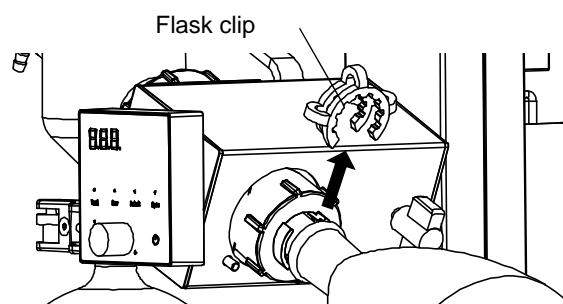

- (4) Take evaporation flask off rotary joint.
If evaporation flask cannot be removed, hold the flask with one hand, and loosen joint nut counterclockwise with the other hand. Flask removal tool gently pushes evaporation flask from the joint.
(During auto-cleaning, the internal pressure is reduced, making it difficult to remove the flask.)

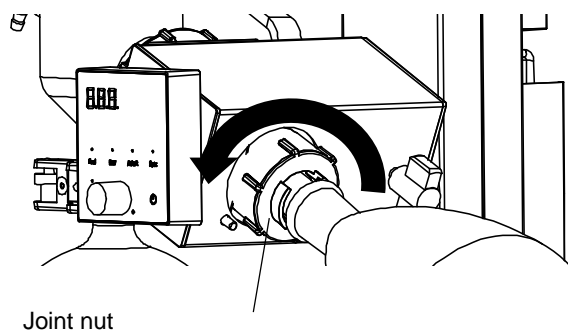

- (5) Carefully remove ball joint clamp while supporting receiving flask.

4. OPERATION PROCEDURES

Stop Operation

- (6) Remove condenser fixing band. * Only for vertical condenser (type B)
- (7) Hold cooling condenser by hand and turn condenser nut counterclockwise. Remove cooling condenser.

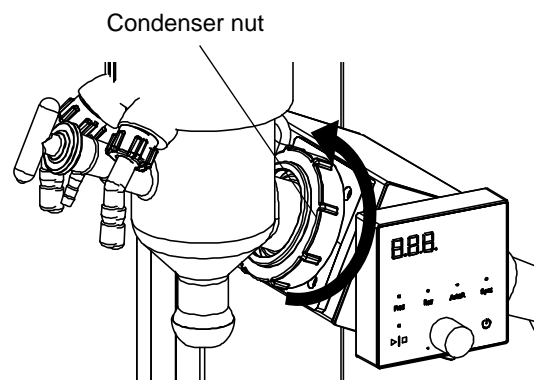

Turn counterclockwise to loosen

5. HANDLING PRECAUTIONS

Warnings and Cautions



WARNING



Exercise caution when handling flammable chemicals

Unit is NOT fire or blast resistant. When processing flammable samples, be sure to provide adequate ventilation and not to allow anything that may be a source of fire or ignition (static electricity, etc.) approached. Do not use this unit in an atmosphere of substances shown in "LIST OF HAZARDOUS SUBSTANCES" (P.62). Never vaporize explosive substances.



Exercise caution when handling toxic, harmful chemicals

When using toxic chemicals, operating in a fume hood or installing exhaust system is strongly recommended. Failure to do so may lead to serious accident.



Turn OFF (○) power immediately when an abnormality occurs

If unit begins emitting smoke or abnormal odors for reasons unknown, turn OFF (○) power immediately, disconnect power cable from power supply, and contact original dealer of purchase for assistance. Continuing to operate without addressing abnormalities may cause fire or electric shock, resulting in serious injury or death. Never attempt to disassemble or repair unit. Repairs should always be performed by a certified technician.



CAUTION



Select appropriate gasket for organic solvents

Although included standard vacuum seal has tolerance to chemicals, it may swell or become deteriorated depending on the types of solvents and conditions of use. In such cases, use of optional PTFE vacuum seal is recommended. (See P.55 "OPTIONAL ACCESSORIES")

Although components used in this unit are corrosion resistant, some solvents may corrode vacuum sensor and solenoid valves. Pay due attention to the type of solvents and conditions of use in order to prevent corrosion and malfunction.



Use caution not to spill samples on equipment

When sample spilled over unit, wipe it dry with a clean dry cloth. Failure to do so may cause coating to peel or corrode.



Inspect regularly.

Regular inspection and maintenance are highly recommended to ensure proper operation. See "Inspection and Maintenance" (P.46)

5. HANDLING PRECAUTIONS

Warnings and Cautions



Power loss recovery

When a power loss occurs during operation and then restored, unit may resume operation or remain on standby. These actions can be selected through user setting. See “Auto-resume Function” (P.38) for setting procedure; default setting is “OFF”.

6. INSPECTION AND MAINTENANCE

Precautions before Inspection



WARNING

- Be sure to disconnect power cable before conducting inspection and maintenance.
- Never attempt to disassemble unit.

Precautions in Daily Maintenance



CAUTION

- Clean unit using soft damp cloth. Never use benzene, paint thinner, scouring powder, scrubbing brush or other abrasives and solvents to clean unit. Superficial damage and/or discoloration, as well as deformity to some components may result.



Maintenance and Inspection

- Check power plug for damage
 - Check power plug for dust or dirt on its prongs, and clear off if any accretions found.
 - Confirm that the prongs of power plug are not bent or damaged. Replace if bent or damaged.
 - Check the power plug for discoloration or abnormal heat generation. If there is discoloration or abnormal heating, the internal contact of the outlet may be faulty.
- Pay attention to the sound of motor
 - If there is an unusual noise comes from motor, contact original dealer of purchase.

◆ Contact original dealer of purchase or Yamato sales office for further assistance.

7. EXTENDED STORAGE AND DISPOSAL

Extended Storage/Disposal

 WARNING	 CAUTION
Extended storage/disposal <ul style="list-style-type: none"> ● Turn OFF (○) power and disconnect power cable. ● Remove all the glass components. 	Disposal <ul style="list-style-type: none"> ● Do not leave unit in a location where children may have access.

Disposal Considerations

Dispose of or recycle this unit in a responsible and environmentally friendly manner.

Yamato Scientific Co., Ltd. strongly recommends disassembling unit, as far as is possible, in order to separate parts and recycle them in contribution to preserving the global environment. Major components and materials, comprising this unit are listed in the table below

[Rotary evaporator]

Component Name	Material
Main Unit Components	
Exterior	Chromium-free electrogalvanized steel sheet, baked-on finish Aluminum, baked-on finish/anodized Polybutylene terephthalate resin (with fiber glass)
Interior	Stainless steel, aluminum
Electrical Parts	
Motor	Composite of resin, aluminum, copper and other materials
Control panel	Polybutylene terephthalate resin (with fiber glass) Polycarbonate resin
Circuit boards	Composite of fiber glass and other materials
Power cable	Composite of synthesized rubber coating, copper, nickel and other compounds
Wiring material	Composites of fiber glass, fire-retardant vinyl, copper, nickel and other compounds
Seals	Resin material
Spring	Stainless steel
Roller	Polyacetal resin
Jack handle	Polyurethane, aluminum

[Vacuum controller]

Component Name	Material
Main Unit Components	
Exterior	Chromium-free electrogalvanized steel sheet, baked-on finish Aluminum, baked-on finish/anodized Polybutylene terephthalate resin (with fiber glass)
Interior	Stainless steel sheet metal
Vacuum sensor	Stainless steel and other materials
Control panel	Polybutylene terephthalate resin (with fiber glass) Polycarbonate resin
Circuit boards	Composite of fiber glass and other materials
Wiring material	Composites of fiber glass, fire-retardant vinyl, copper, nickel and other compounds
Seals	Resin material
Fitting (external)	Polypropylene
Fitting (internal)	Stainless steel
Tubing	PTFE

8. TROUBLESHOOTING

Reading Error Codes (Control Panel 1)

Unit has a self-diagnostic function built into the CPU board. The table below shows possible causes and measures to take when safety function is performed.

[Error Codes]

When an operational error or malfunction occurs, an error code is displayed on the control panel. When an error occurs, confirm the error code and terminate operation immediately.

Display code	Description	Possible causes and solutions
E 72	Motor failure (E72)	<ul style="list-style-type: none"> ● Motor overload ● Overvoltage ● Voltage drop ● Rotary sensor failure Turn OFF (○) power and restart If unit does not reset, contact original dealer of purchase
E 15	EEPROM failure (E15)	<ul style="list-style-type: none"> ● Error in a storage element EEPROM on the controller board Turn OFF (○) power and restart If unit does not reset, contact original dealer of purchase

Other warnings (displayed alternately with rpm reading)

Display alert	Alert description	Possible causes and solutions
"Pon" displayed after power is restored	Power failure notification	<ul style="list-style-type: none"> ● When a power failure occurs during operation, rpm reading and "Pon" are displayed alternately on the control panel to indicate that a power failure has occurred. Turn OFF (○) power and restart ● With auto-resume function "ON", unit resumes operation. Remain standby when set to "OFF".

8. TROUBLESHOOTING

Reading Error Codes (Control Panel 2)

[Error Indication] When an abnormality is detected, unit stops operation sounding a buzzer that indicates the occurrence of an error, and forcibly opens the leak valve. When an error occurs, an error code is displayed in the LCD screen. Confirm the code and turn OFF power immediately.

* See VR102S instruction manual for details.



Display code	Possible causes and solutions
Er00 Communication error	<p>When the interlock setting is "On" and there is no response from the connected device for a certain period of time.</p> <ul style="list-style-type: none"> ○ Vacuum pump control unit/unit G is turned OFF. ○ The distance between this unit and the wirelessly connected device is 10 m or more. ○ There is a wall or metal obstacles between this unit and the wirelessly connected device. ● Failure in the connected device ● Defective board <p>Address the above causes with a white circle, then turn OFF (○) power and restart unit. If unit does not reset, contact original dealer of purchase.</p>
Er01 Pressure sensor failure	<p>Pressure reading has come out of the measurement range.</p> <ul style="list-style-type: none"> ○ The pressure sensor is pressurized (IN/OUT misconnection of the vacuum pump, etc.) ● Defective pressure sensor <p>Address the above causes with a white circle, then turn OFF (○) power and restart unit. If unit does not reset, contact original dealer of purchase.</p>
Er05 Leak error	<p>Open to the atmosphere for one minute after cleaning operation. Check the pressure and there may be a leak if it is below 900 hPa/675mmHg(Torr)/90.0 kPa.</p> <ul style="list-style-type: none"> ○ Vacuum piping is blocked ● Leak solenoid valve failure <p>Address the above causes with a white circle, then turn OFF (○) power and restart unit. If unit does not reset, contact original dealer of purchase.</p>
Er15 Memory error	<p>Checksum at startup detects error in EEPROM.</p> <p>Turn OFF (○) power and restart. If unit does not reset, contact original dealer of purchase.</p>
Er25 High pressure abnormality	<p>When the measured pressure becomes 1120 hPa (mbar)/840 mmHg (Torr)/112.0 kPa or higher.</p> <p>* When the pressure exceeds 1060 hPa(mbar)/795 mmHg (Torr)/106.0 kPa, leak valve opens.</p> <ul style="list-style-type: none"> ○ The pressure sensor is pressurized (IN/OUT misconnection of the vacuum pump, etc.) ○ Vacuum piping is blocked ● Leak solenoid valve failure <p>Address the above causes with a white circle, then turn OFF (○) power and restart unit. If unit does not reset, contact original dealer of purchase.</p>

8. TROUBLESHOOTING

Troubleshooting Guide

Troubles

Symptom	Possible causes	Possible measures
RPM display remains blank when the Power key is pressed. (Control panel 1)	<ul style="list-style-type: none"> ● Power supply failure ● AC adapter failure ● Power cable failure ● Controller failure 	<ul style="list-style-type: none"> ● Regulate the supply voltage to the rated voltage of unit ● Replace relevant parts (call for service) ● Replace relevant parts (call for service) ● Replace relevant parts (call for service)
RPM display remains blank when the Power key is pressed. (Control panel 2)	<ul style="list-style-type: none"> ● Connection cable is disconnected ● Controller failure ● Connection cable failure 	<ul style="list-style-type: none"> ● Check the connection ● Replace relevant parts (call for service) ● Replace relevant parts (call for service)
Evaporation flask does not rotate when the Run/Stop key is ON	<ul style="list-style-type: none"> ● External temperature is below 5 °C ● Motor failure ● Bearing failure ● Drive belt failure ● Circuit board failure 	<ul style="list-style-type: none"> ● Control the environmental temperature between 5 °C and 35 °C ● Replace relevant parts (call for service) ● Replace relevant parts (call for service) ● Replace relevant parts (call for service) ● Replace relevant parts (call for service)
Unit does not start decompression when the Run/Stop key is ON	<ul style="list-style-type: none"> ● Improper setting value ● Vacuum pump is turned OFF ● There is a vacuum leak from the piping or decompression vessel ● The piping is not properly connected. ● Leak solenoid valve failure ● Circuit board failure 	<ul style="list-style-type: none"> ● Check the setting value and unit setting. ● Check power supply ● Check the piping system ● Check the piping system ● Replace relevant parts (call for service) ● Replace relevant parts (call for service)
Rotation speed on the control panel 1 is not stable	<ul style="list-style-type: none"> ● Sample volume is excessive ● Circuit board failure ● Motor failure ● Pulley/belt failure 	<ul style="list-style-type: none"> ● Reduce sample load or lower the rotation speed ● Replace relevant parts (call for service) ● Replace relevant parts (call for service) ● Replace relevant parts (call for service)
Unusual noise comes from unit during rotation	<ul style="list-style-type: none"> ● Vacuum seal is worn ● Joint nut is loose ● Motor failure ● Bearing failure ● Pulley/belt failure 	<ul style="list-style-type: none"> ● Replace relevant parts (call for service) ● Re-tighten joint nut ● Replace relevant parts (call for service) ● Replace relevant parts (call for service) ● Replace relevant parts (call for service)
Weak or no decompression (vacuum)	<ul style="list-style-type: none"> ● Vacuum seal is worn ● Rotary joint is worn ● Rotary joint is not set up properly ● Nozzle gasket is worn ● Vacuum hose is deteriorated 	<ul style="list-style-type: none"> ● Replace relevant parts (call for service) ● Replace relevant parts (call for service) ● Check that rotary joint is installed properly (P.23) ● Replace relevant parts (call for service) ● Replace relevant parts (call for service)
Jack does not work properly	<ul style="list-style-type: none"> ● Deterioration of jack mechanism ● Spring is deteriorated ● Bearing is worn 	<ul style="list-style-type: none"> ● Replace relevant parts (call for service) ● Replace relevant parts (call for service) ● Replace relevant parts (call for service)
Jack does not lock	<ul style="list-style-type: none"> ● Components in lock mechanism are worn or deteriorated 	<ul style="list-style-type: none"> ● Replace relevant parts (call for service)
Rotary joint cannot be inserted	<ul style="list-style-type: none"> ● Rotary joint lock mechanism is worn or deteriorated 	<ul style="list-style-type: none"> ● Replace relevant parts (call for service)

8. TROUBLESHOOTING

Troubleshooting Guide

Rotary joint cannot be pulled out	<ul style="list-style-type: none"> ● Rotary joint lock mechanism is stuck, worn or deteriorated 	<ul style="list-style-type: none"> ● Gently tap rotary joint with plastic head hammer to remove. Use caution not to break the rotary joint ● Replace relevant parts (call for service)
Motor box angle cannot be adjusted	<ul style="list-style-type: none"> ● Rotary part is worn ● Rotary part grease dry-out 	<ul style="list-style-type: none"> ● Replace relevant parts (call for service) ● Replace relevant parts (call for service)
Control panel cannot rotate	<ul style="list-style-type: none"> ● Gasket is worn 	<ul style="list-style-type: none"> ● Replace relevant parts (call for service)
The pressure does not return to atmospheric pressure when the leak key on the control panel 2 is pressed.	<ul style="list-style-type: none"> ● Leak solenoid valve failure 	<ul style="list-style-type: none"> ● Replace relevant parts (call for service)
Control panel 1 and 2 do not work together	<ul style="list-style-type: none"> ● Connection cable is disconnected ● Interlock function is set to OFF ● Connection cable is broken ● Connector failure ● Circuit board failure 	<ul style="list-style-type: none"> ● Check the connection ● Check the settings ● Replace relevant parts (call for service) ● Replace relevant parts (call for service) ● Replace relevant parts (call for service)

◆ If problem persists or is not applicable to any of errors above, turn off power immediately, disconnect power cable and contact original dealer of purchase for assistance.

9. SERVICE & REPAIR

Requests for Repair

Applicable model: REV202M

Warranty card (attached separately)

Warranty card will be handed by dealer or Yamato personnel upon delivery and installation, or will be attached to equipment if no one from dealer or Yamato is to be present at delivery and installation.

Register warranty card at <https://www.yamato-net.co.jp/support/warranty.htm>

- Keep warranty card safe.

Requests for Repair

If abnormalities remain after confirming "Troubleshooting Guide", terminate operation, turn OFF (○) ELB, and disconnect power cable. Contact original dealer of purchase or Yamato sales office for assistance.

The following information is required for all repairs.

- Product Name
 - Model
 - Serial Number
 - Date (year/month/day) of Delivery
 - Description of problem in as much detail as possible
- } Refer to warranty card.
- Repair this equipment for free of charge according to the contents on warranty card. Warranty period is 1 (one) year from date of purchase.
 - Consult with original dealer of purchase or Yamato sales office for any repair after warranty ended. Charged repair service of this equipment will be available on customer's request when it can be maintained functional by its repair.

* Be sure to present warranty card to the service representative.

Guaranteed Supply Period for Repair Parts

Guaranteed maximum supply period for repair parts is 7 (seven) years from date of discontinuation for this equipment.

"Repair parts" is defined as components which, when installed, allow for continued equipment operation.

10. SPECIFICATIONS

Specifications

Model		REV202M series	REV202M series + RG202A series	REV202M series + RG202B, E series
Performance *1	Operating ambient temperature range	5-35 °C		
	Speed range	5-315 rpm *3		
	Pressure setting range	0-1013 hPa		
	Evaporation capacity	---	Up to 23 mL/min (for water)	
Description	RPM display	Setting with Digital display/Control knob		
	Rotation mode	Forward/Reverse/Auto inversion		
	Spring-loaded jack	Manual balance (Max. height 200 mm, stepless regulation, one-touch lock)		
Configuration	Vacuum controller	VR102S, installed above jack handle with attachment bracket		
	Vacuum control solenoid valve	OVR10, installed in the rear of stand base		
	Rotary motor	DC brushless (simple servo)		
	Condenser retention	---	---	Condenser bracket
Safety functions		Rotary evaporator: motor overload protection, overvoltage, low voltage, rotation speed sensor error, AC adapter: short circuit in internal circuit, overcurrent protection, overvoltage protection Vacuum controller: Communication error, Pressure sensor error, Memory error, Leak error, High pressure error, Auto leak at error occurrence		
Standard	Cooling condenser	---	RG202A series: Double corrugated tube (cooling area 0.143 m ²) RG202B series: Double corrugated tube (cooling area 0.143 m ²) RG202E series: Double corrugated tube (cooling area 0.149 m ²)	
		---	Suction port: GL-14 (lower), φ10 nozzle	Suction Port: GL-14 (upper), φ10 nozzle
		---	Cooling port: GL14 (two places in lower part), two φ10 nozzles	
	Compatible evaporation flask	50-2000ml (JIS) * Use optional reducer to attach small flasks.		
	Compatible receiving flask	100-2000 mL		
	External dimensions *2	375W × 445H × 324D	719W × 324D × 534H	529W × 324D × 745H
	Overall dimensions *2 (Including bath)	---	744W × 365D × 534H	554W × 365D × 745H
	Power supply	REV202M: 100 V ±5 % 1 A 50/60 Hz REV202M-A: 115 V ±5 % 1 A 60 Hz REV212M-A: 230 V ±5 % 1 A 60 Hz REV212M-B: 220 V ±5 % 1 A 50 Hz REV212M-D: 220 V ±5 % 1 A 60 Hz		
	Power cable	Approx. 2.0 m with inlet plug		
	Weight	Approx. 8.5 kg	Approx. 10.5 kg (including cooling condenser)	
Accessories	[Main unit] REV202M series instruction manual (1), VR102S series instruction manual (1) Warranty card (1) *4 AC adapter (1), Power cable (1), Bath guide Rear cover (1), Tape fastener (single-sided) (1 roll), Tape fastener (double-sided) (1 roll) Exhaust hose (1 roll)			
	[Glass set] Cooling condenser type A/B/E (1), Rotary joint (1), Evaporation flask (1), Receiving flask (1), ball joint clamp (1), Flask clip (1), Vacuum seal (1), Condenser insulation (1 set), Flask removal tool, Condenser bracket (1)(only for type B and E)			

*1 Performance data above based on 23 ±5 °C room temperature, 65%RH ±20% humidity.

*2 Dimensions do not include protrusions.

*3 Applicable rotation speed range and sample volume depend on the capacity of evaporation flask.

*4 REV202M, REV202M-A, REV212M-A, REV212M-B only

Evaporation flask capacity	Liquid samples		Powdery samples	
	Rough standard of sample capacity	Rotation speed (rpm)	Rough standard of sample capacity	Rotation speed (rpm)
50-500 mL	Half the total flask capacity	315	Half the total flask capacity	315
1000 mL				150
2000 mL		Not available		

10. SPECIFICATIONS

List of Consumable Parts

Some components attached or built into this unit with different lifespans, depending on the use conditions, and environment are regarded as consumables. It is recommended to replace these parts as needed.

The components listed below are not covered by the warranty.

[Consumables/replacement parts for main unit]

① Sleeve Part code: LT00040261	② PTFE tube (length 700 mm) Part code: R102S0002	③ Pressure sensor *1 Part code: LT00039519
④ Leak solenoid valve *1 Part code: T00040031	⑤ Vacuum control solenoid valve Product code: 255762	⑥ Exhaust hose (for purging) Part code: ORT12S0001

*1: These components are embedded inside unit. If there is suspicion of malfunction, contact original dealer of purchase.

11. OPTIONAL ACCESSORIES

Consumables/Replacement Parts/Options

[RG202A series]

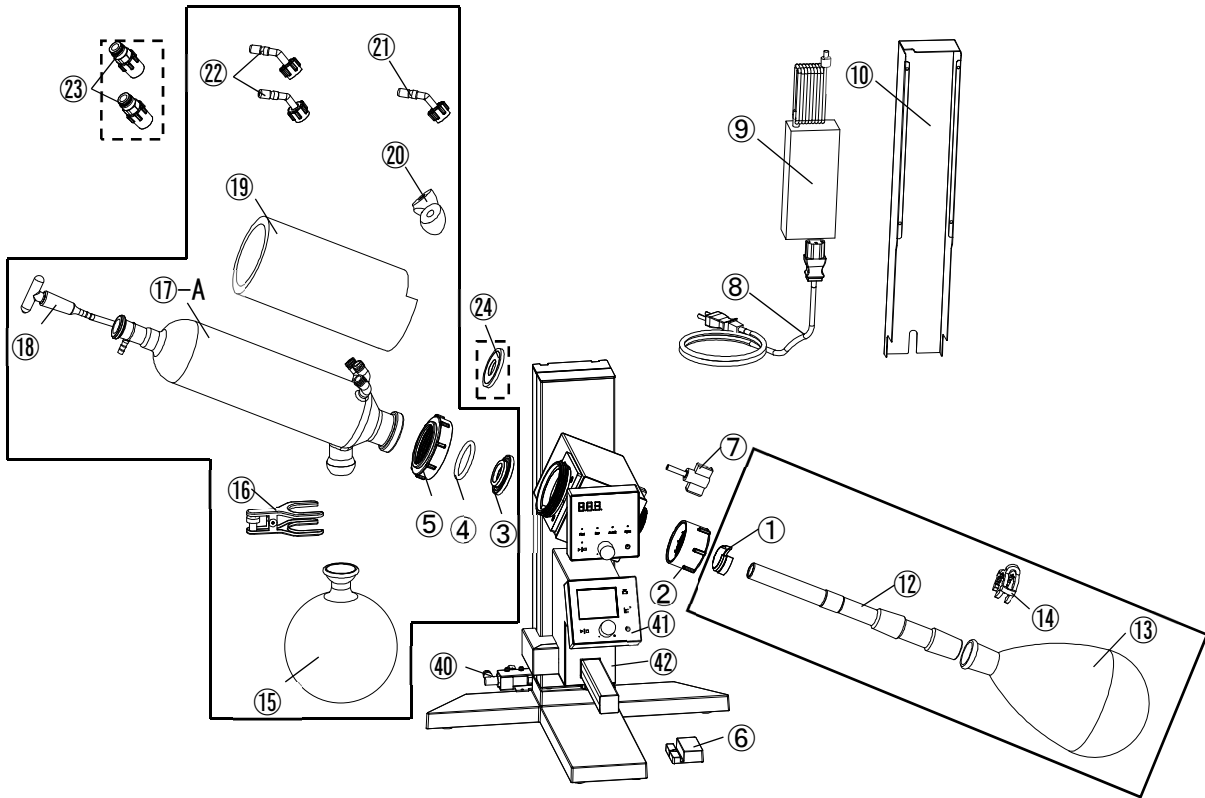

[RG202B series, RG202E series]

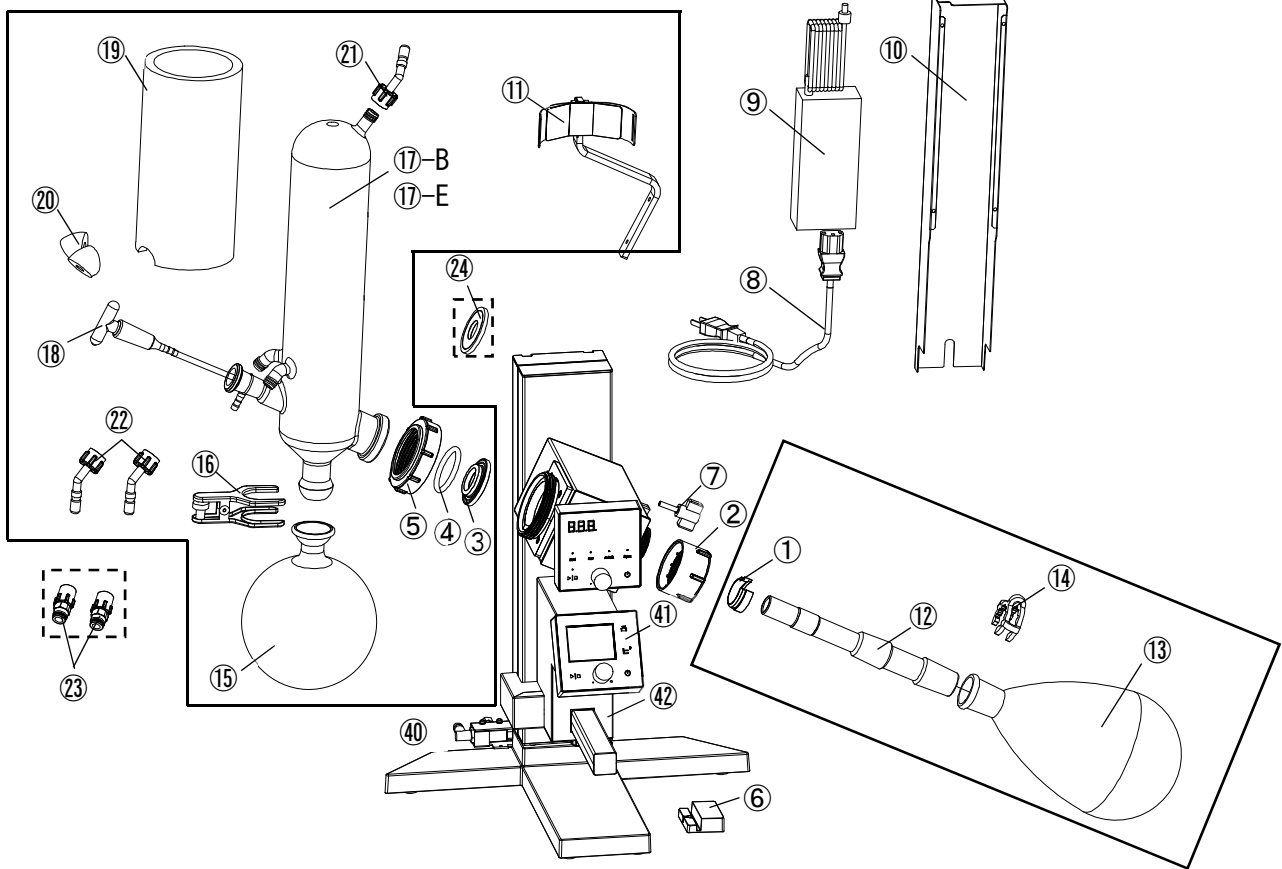



▭ : Glass set accessories ▭ : Optional accessories

11. OPTIONAL ACCESSORIES



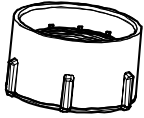
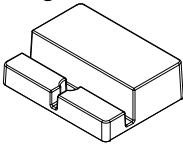
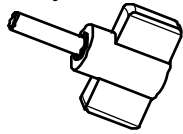

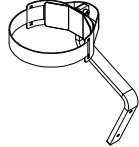
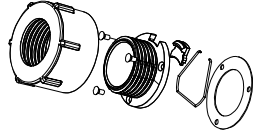

Consumables/Replacement Parts/Options

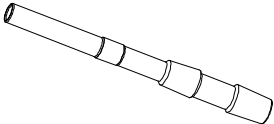
[Consumables/replacement parts for main unit]

<p>② Joint nut</p>  <p>Part code RE20230071</p>	<p>⑥ Bath guide</p>  <p>Part code RE20240902</p>	<p>⑦ Tilt adjustment screw</p>  <p>Part code RE20245600</p>	<p>⑩ Adapter cover</p>  <p>Part code RE20242310</p>
<p>⑪ Condenser bracket</p>  <p>Part code RE20245700</p>	<p>③⑨ Joint parts set</p>  <p>Part code RE202S0010</p>	<p>⑨ AC adapter power supply For REV202M (PSE, UL) Part code: LT00039663 For REV202M-A (PSE, UL) Part code: LT00039663 For REV212M-A (PSE, UL) Part code: LT00039663 For REV212M-B (CCC) Part code: LT00039816 For REV212M-D (KC) Part code: LT00039817</p> <p>⑧ Power cable For REV202M (A type, PSE) Part code: LT00039664 For REV202M-A (A type, UL) Part code: LT00039665 For REV212M-A (M4 ring terminal) Part code: RE21239410-47 For REV212M-B (O type, CCC) Part code: LT00039666 For REV212M-D (SE type, KC) Part code: LT00039667</p>	
<p>For cooling condenser type B</p>	<p>A set of rotary joint fittings</p>	<p>Used to supply power to this unit.</p>	

[Consumables/replacement parts for glass set]

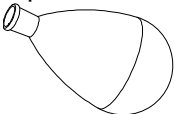
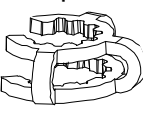
⑫ Rotary joint	For	Standard type	Clear ground joint type
	RG202A	Standard: ¥ 29/38 Product code: 255720	Standard: ¥ 29/38 Product code: 255724
		Standard: ¥ 24/40 Product code: 255722	Standard: ¥ 24/40 Product code: 255726
	RG202B	Standard: ¥ 29/38 Product code: 255721	Standard: ¥ 29/38 Product code: 255725
		Standard: ¥ 24/40 Product code: 255723	Standard: ¥ 24/40 Product code: 255727

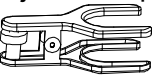
<p>① Flask removal tool</p>  <p>Part code ¥ 29: RE20241185 ¥ 24: RE20241194</p>	<p>④ Coil ring</p>  <p>Part code 2551720503</p>	<p>③ Vacuum seal (standard)</p>  <p>Product code 255740</p>	<p>⑤ Condenser nut</p>  <p>Part code RG02A30122</p>
		<p>Material: FKM, PTFE (one side)</p>	
<p>⑬ Evaporation flask</p>  <p>Product code ¥ 29/38: 255705 ¥ 24/40: 255712</p>	<p>⑭ Flask clip</p>  <p>Product code ¥ 29: 255747 ¥ 24: 255748</p>	<p>⑮ Receiving flask</p>  <p>Product code 255718</p>	<p>⑯ Ball joint clamp</p>  <p>Product code 255749</p>
<p>1 L</p>		<p>S35/20, 1L</p>	<p>S35/20</p>

11. OPTIONAL ACCESSORIES

Consumables/Replacement Parts/Options

[Consumables/replacement parts for main unit]

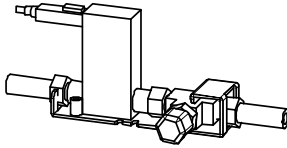
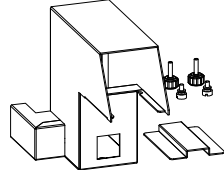
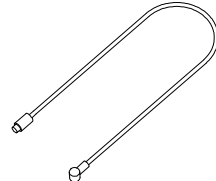
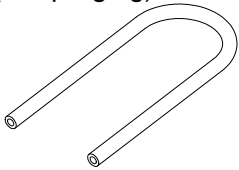
<p>④⑩ Vacuum control solenoid valve</p>  <p>Product code 255762</p>	<p>④② VR attachment bracket</p>  <p>Part code REV02S0010</p>	<p>④③ Connection cable</p>  <p>Product code LT00040442</p>	<p>④④ Exhaust hose (For purging)</p>  <p>Part code ORT12S0001</p>
<p>VR102S connection cable and vacuum tube included</p>	<p>Fittings and knurled screws</p>	<p>For VR102S/RE202 connection</p>	<p>φ7.94 x φ14.3 x 1 m</p>

* See VR102S instruction manual for consumables for VR102S.



11. OPTIONAL ACCESSORIES

List of Options

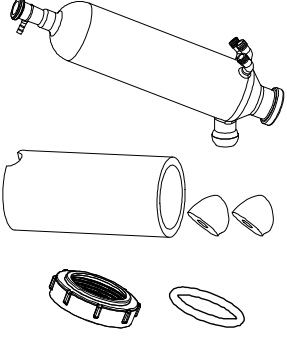
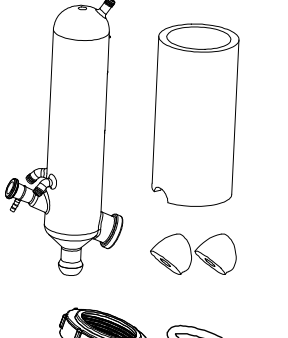
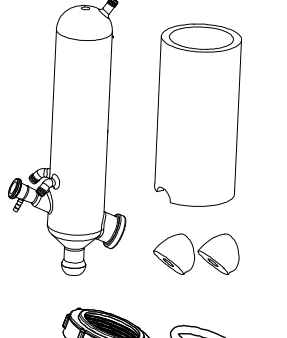
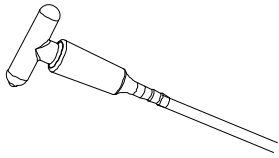
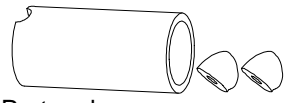
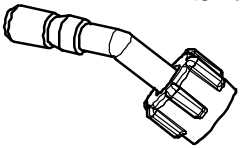
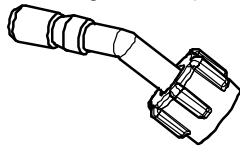
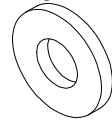
Consumables/replacement parts for glass set

<p>⑰-A Cooling condenser type A</p>  <p>Product code: 255750</p>	<p>⑰-B Cooling condenser type B</p>  <p>Product code: 255751</p>	<p>⑰-E Cooling condenser type E</p>  <p>Product code: 255753</p>	<p>⑱ Sample feed stopcock</p>  <p>Product code: 255738</p>
<p>Condenser insulation kit, condenser nut, coil ring included Cooling surface: 0.143 m²</p>	<p>Condenser insulation kit, condenser nut, coil ring included Cooling surface: 0.143 m²</p>	<p>Condenser insulation kit, condenser nut, coil ring included Cooling surface: 0.149 m² (Destination: China and South Korea only)</p>	<p>¥ 19/38 PTFE tube included * Cut in 345 mm for condenser type B</p>
<p>⑲⑳ Condenser insulation kit</p>  <p>Part code: RG02AS0000</p>	<p>㉑ Vacuum nozzle (gray)</p>  <p>Product code: 255512</p>	<p>㉒ Cooling nozzle (black)</p>  <p>Product code: 255742</p>	<p>㉓ Nozzle gasket</p>  <p>Product code: 281494</p>
<p>Common insulation for cooling condensers</p>	<p>GL14 φ10 mm O.D. 2 pcs</p>	<p>GL14 φ10 mm O.D. 2 pcs</p>	<p>Gasket for ㉑㉒vacuum nozzle, 12pcs</p>

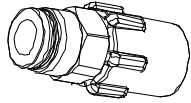
Options

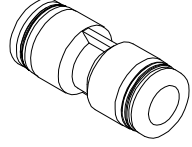
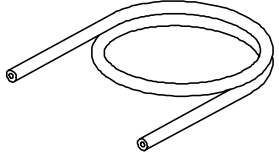
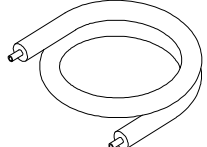
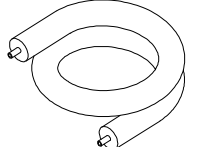
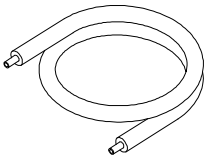
<p>㉓ One-touch connector</p>  <p>Product code: 255743</p>	<p>㉔ PTFE vacuum seal</p>  <p>Product code: 255741</p>	<p>㉕ Junction connector</p>  <p>Product code: 255744</p>	<p>㉖ Vacuum hose</p>  <p>Product code: 255297</p>		
<p>GL14 φ10, 2pcs Used for connecting ㉑ thermal insulation hose to cooling condenser</p>	<p>Material PTFE Chemical resistant</p>	<p>For extending 10 mm O.D. rigid tube (㉑)</p>	<p>φ6 × φ15 × 5m</p>		
<p>㉙ Thermal insulation hose (flexible)</p> 	<p>㉚ Thermal insulation hose (flexible)</p> 	<p>㉛ Thermal insulation hose (rigid)</p> 			
<p>Qty.</p>	<p>Product code</p>	<p>Qty.</p>	<p>Product code</p>	<p>Qty.</p>	<p>Product code</p>
<p>1</p>	<p>281330</p>	<p>1</p>	<p>281331</p>	<p>1</p>	<p>281332</p>
<p>2</p>	<p>221581</p>	<p>2</p>	<p>221599</p>	<p>2</p>	<p>281475</p>
<p>φ9 × φ13 × 2 m (insulation: 28 mm O.D.) Hose clamp, 4 pcs Hose material: EPDM</p>		<p>φ9 × φ14 × 2 m (insulation: 41 mm O.D.) Hose clamp, 4 pcs Hose material: Silicon</p>		<p>φ6.5 × φ10 × 2 m (insulation: 22 mm O.D.) Hose material: polyurethane</p>	

11. OPTIONAL ACCESSORIES

List of Options

[Options] (Product code)

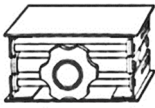
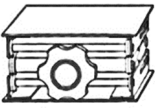
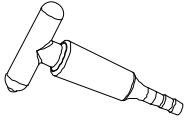
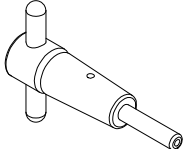
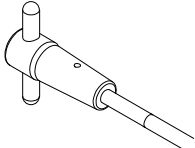
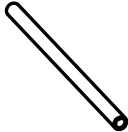
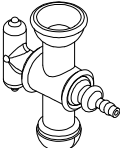
 ③② Lab jack Product code: 255745	 ③③ Lab jack Product code: 255746	 ③④ Stopcock Product code: 255736	 ③⑤ Stopcock Product code: 255735
150 x 150 mm Height 75-245 mm	200 x 200 mm Height 75-245 mm	Material: glass	Material: PTFE
 ③⑥ Sample feed stopcock Product code: 255738	 ③⑦ Sample feed tube Product code: 255739	 ③⑧ Three way tap Product code: 255363	
Material: PTFE PTFE tube included * Cut in 345 mm for condenser type B	L520 mm * Cut in 345 mm for condenser type B	S35/20	

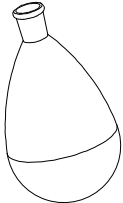
	Capacity/standard	₹ 29/38	₹ 24/40
	100 mL	Product code: 255701	Product code: 255708
	200 mL	Product code: 255702	Product code: 255709
	300 mL	Product code: 255703	Product code: 255710
	500 mL	Product code: 255704	Product code: 255711
	1000 mL	Product code: 255705	Product code: 255712
	2000 mL	Product code: 255706	Product code: 255713

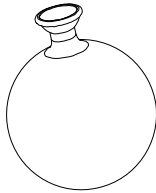
	Capacity/standard	S35/20
	100 mL	Product code: 255714
	200 mL	Product code: 255715
	300 mL	Product code: 255716
	500 mL	Product code: 255717
	1000 mL	Product code: 255718
	2000 mL	Product code: 255719

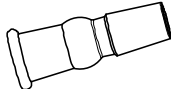
	Standard (female → male)						
	₹ 24/40	₹ 24/40	₹ 24/40	₹ 29/38	₹ 29/38	₹ 29/38	₹ 29/38
	↓	↓	↓	↓	↓	↓	↓
Product code	255732	255733	255734	255729	255730	255731	255728

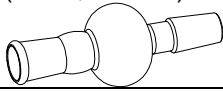
	Standard (female → male)			
	₹ 29/42	₹ 29/42	₹ 29/42	₹ 29/42
	↓	↓	↓	↓
Part code	RE200GT003	RE200GT001	RE200GT004	RE200GT002

11. OPTIONAL ACCESSORIES

List of Options

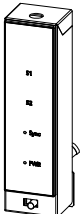
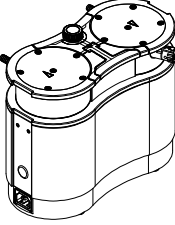
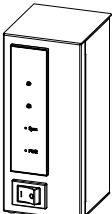
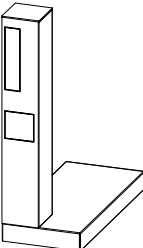
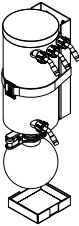
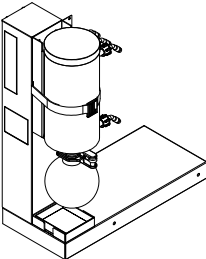
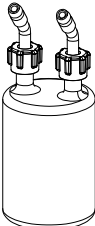
<p>① Vacuum pump control unit G Model: OVR26 Product code: 255783</p>  <p>Linked with this unit wireless.</p>	<p>② Diaphragm vacuum pump Model: N820G Product code: 255161</p> 	<p>③ Vacuum pump control unit Model: OVR28 Item code 255784</p>  <p>Linked with this unit wireless.</p>
<p>Regulates motor speed of the vacuum pump to control the degree of vacuum. Can be installed onto N820G. ■ Applicable vacuum pump Yamato Scientific N820G</p>	<p>Exhaust speed can be controlled with flow adjustment knob. (adjustable range: 9-20L/min). Can be controlled via VR102S by installing OVR26.</p>	<p>Turns ON/OFF the connected pump and control the degree of vacuum. Can be installed onto Stand. ■ Applicable AC pump Yamato Scientific PG201 ULVAC DTC-22, DTC-41 KNF: N810, N820, N840</p>
<p>④ Stand Model: ORT10 Product code 255770</p> 	<p>⑤ Exhaust trap kit Model: ORT12 Product code: 255773</p> 	<p>⑥ Solvent recovery unit RT302 Model: RT302 Product code: 255378</p> 
<p>Stand for VR102S, Vacuum pump control unit, and Vacuum pump. Waste liquid trap bottle (250 mL) included</p>	<p>Can be used as a solvent recovery unit by installing onto ORT10. Exhaust trap, 500 mL flasks, tray, connection hose on the OUT side, and a set of attachment brackets</p>	<p>Allows efficient solvent recovery by cooling water circulation. Connected to the exhaust side of a diaphragm vacuum pump. Set of ④ and ⑤.</p>
<p>⑦ Waste liquid trap bottle Model: ORT14 Product code: 255772</p> 		
<p>Waste liquid trap bottle (250 mL), ϕ10 vacuum nozzle (IN & OUT) included. Can be used as a replacement for the bottle included with ORT10.</p>		

12. REFERENCE DATA

Solvent Boiling Point

Substance	Chemical formula	Molecular weight	Density (g/cm ³) (20 °C)	Latent heat of vaporization (cal/g) (1013 hPa)	Boiling point (°C) (1013 hPa)	Degree of vacuum at each boiling point (hPa)		
						Boiling Point		
						25 °C	30 °C	40 °C
Diethyl ether	C ₄ H ₁₀ O	74.1	0.736	89.8	34.6	712	859	Atm. pressure
n-pentane	C ₅ H ₁₂	72.7	0.626	92.6	36.1	678	931	Atm. pressure
Ethyl bromide	C ₂ H ₅ Br	109.0	1.451	549.7	38.4	625	753	Atm. pressure
Dichloromethane	CH ₂ Cl ₂	84.9	1.326	78.7	39.8	580	706	Atm. pressure
1,2-Dichloroethylene	C ₂ H ₂ Cl ₂	97.0	1.284	75.0	48.0	532	452	798
Cyclopentane	C ₅ H ₁₀	70.1	0.745	97.2	49.0	423	514	740
Acetone	C ₃ H ₆ O	58.1	0.788	125.0	56.3	307	378	562
1-1-Dichloroethane	C ₂ H ₄ Cl ₂	99.0	1.175	69.0	57.4	306	359	539
Methyl acetate	C ₃ H ₆ O ₂	74.1	0.934	98.1	57.8	289	359	541
Chloroform	CHCl ₃	119.4	1.486	58.8	61.3	260	320	474
Methanol	CH ₄ O	32.0	0.794	264.0	64.7	169	218	354
n-hexane	C ₆ H ₁₄	86.2	0.659	91.8	68.7	202	249	373
Carbon tetrachloride	CCl ₄	153.8	1.595	46.6	76.8	152	173	284
Ethyl acetate	C ₄ H ₈ O ₂	88.1	0.901	88.2	77.1	129	163	254
Ethanol	C ₂ H ₆ O	46.0	0.785	204.0	78.4	79	105	179
Benzene	C ₆ H ₆	78.1	0.874	94.2	80.1	127	159	244
2-propanol	C ₃ H ₈ O	74.1	0.786	159.2	82.0	60	81	142
1-2-Dichloroethane	C ₂ H ₄ Cl ₂	99.0	1.257	77.3	83.5	111	146	199
1-propanol	C ₃ H ₈ O	60.1	0.804	162.6	97.8	27	38	70
2-butanol	C ₄ H ₁₀ O	74.1	0.807	134.4	99.5	24	34	63
water		18.0	0.997	540.0	100.0	32	43	74
Formic acid	CH ₂ O ₂	46.0	1.214	120.4	100.6	57	73	114
Propyl acetate	C ₅ H ₁₀ O ₂	102.1	0.889	80.3	101.8	44	57	94
Toluene	C ₇ H ₈	92.2	0.866	98.6	110.6	38	49	79
1, 1, 2-trichloroethane	C ₂ H ₃ Cl ₃	133.4	1.442	68.7	113.5	33	40	68
1-butanol	C ₄ H ₁₀ O	74.1	0.810	141.3	117.7	8	12	24
Acetic acid	C ₂ H ₄ O ₂	60.0	1.050	4.8	118.0	20	27	46
2-pentanol	C ₅ H ₁₂ O	88.2	0.810	97.8	119.3	8	12	21
Tetrachloroethylene	C ₂ Cl ₄	165.8	1.623	50.0	121.0	24	31	53
Isoamyl alcohol	C ₅ H ₁₂ O	88.1	0.809	116.0	130.8	4	7	12
Chlorobenzene	C ₆ H ₅ Cl	112.6	1.106	77.4	131.7	16	21	35
1-pentanol	C ₅ H ₁₂ O	88.2	0.814	120.6	138.0	4	5	9
m-Xylene	C ₈ H ₁₀	106.2	0.860	81.9	139.1	13	15	25
o-Xylene	C ₈ H ₁₀	106.2	0.876	82.9	144.4	9	13	20
Styrene	C ₈ H ₈	104.2	0.901	100.8	145.2	10	13	19
						Degree of vacuum at each boiling point (hPa)		
						Boiling Point		
						70 °C	90 °C	120 °C
Styrene	C ₈ H ₈	104.2	0.901	100.8	145.2	81	180	494
1-hexanol	C ₆ H ₁₄ O	102.2	0.819	107.2	157.1	24	69	265
Butyric acid	C ₄ H ₈ O ₂	88.1	0.958	113.9	163.5	20	57	199
1-heptanol	C ₇ H ₁₆ O	116.2	0.822	438.9	176.3	9	33	133
1-octanol	C ₈ H ₁₈ O	130.2	0.824	98.2	195.2	4	13	67
Ethylene glycol	C ₂ H ₆ O ₂	62.1	1.116	219.8	197.4	4	12	53
Capric acid	C ₆ H ₁₂ O	116.2	0.927	133.0	205.8	3	8	40
1-nonanol	C ₉ H ₂₀ O	114.3	0.827	134.0	213.5	3	8	37
Glycerin	C ₃ H ₈ O ₃	92.1	1.262	158.4	290.0	5 hPa/150		

13. LIST OF HAZARDOUS SUBSTANCES

Table 13.1 List of hazardous substances

Explosive substances	① Nitroglycol, Glycerine trinitrate, Cellulose Nitrate and other explosive nitrate esters
	② Trinitrobenzen, Trinitrotoluene, Picric Acid and other explosive nitro compounds
	③ Acetyl Hydroperoxide, Methyl Ethyl Ketone Peroxide, Benzoyl Peroxide and other organic peroxides
	④ Metallic Azide, including Sodium Azide, etc.
Combustible substances	① Metal "Lithium" ② Metal "Potassium" ③ Metal "Natrium" ④ Yellow Phosphorus
	⑤ Phosphorus Sulfide ⑥ Red Phosphorus ⑦ Phosphorus Sulfide
	⑧ Celluloids, Calcium Carbide (a.k.a, Carbide) ⑨ Lime Phosphide ⑩ Magnesium Powder
	⑪ Aluminum Powder ⑫ Metal Powder other than Magnesium and Aluminum Powder
	⑬ Sodium Dithionous Acid (a.k.a., Hydrosulphite)
Oxidizing substances	① Potassium Chlorate, Sodium Chlorate, Ammonium Chlorate, and other chlorates
	② Potassium Perchlorate, Sodium Perchlorate, Ammonium Perchlorate, and other perchlorates
	③ Potassium Peroxide, Sodium Peroxide, Barium Peroxide, and other inorganic peroxides
	④ Potassium Nitrate, Sodium Nitrate, Ammonium Nitrate, and other nitrates
	⑤ Sodium Chlorite and other chlorites
	⑥ Calcium Hypochlorite and other hypochlorites
Flammable substances	① Ethyl Ether, Gasoline, Acetaldehyde, Propylene Chloride, Carbon Disulfide, and other substances having ignition point of 30 or more degrees below zero.
	② n-hexane, Ethylene Oxide, Acetone, Benzene, Methyl Ethyl Ketone and other substances with ignition point between 30 degrees below zero and less than zero.
	③ Methanol, Ethanol, Xylene, Pentyl n-acetate, (a.k.a. amyl n-acetate) and other substances having ignition point of between zero and less than 30 degrees.
	④ Kerosene, Light Oil, Terebinth Oil, Isopenthyll Alcohol (a.k.a. Isoamyl Alcohol), Acetic Acid and other substances having ignition point of between 30 degrees and less than 65 degrees.
Combustible gas	Hydrogen, Acetylene, Ethylene, Methane, Ethane, Propane, Butane and other gases combustible at 15°C, ambient air pressure.

14. STANDARD INSTALLATION MANUAL

Install this equipment according to following format (check options and special specifications separately).

Model	Serial Number	Installation Date	Charged Personnel or Company Name for Installation	Installation proved by	Judgment

No	Item	Implementation method	Chapter No. & Reference page of instruction manual	Judgment
Specifications				
1	Accessories	Quantity check according to the accessories column	COMPONENT NAMES AND FUNCTIONS P.8	
2	Installation	-Visual check of surrounding conditions Caution: Take care for environment -Securing a space	3. PRE-OPERATION PROCEDURES -Choose an appropriate... P.16	
Operation-related matters				
1	Power supply voltage	-Measure line voltage (power distribution board of facilities, outlet etc.) with a tester. -Measure line voltage during operation (must meet required voltage) Caution: Use a compliant plug to install	3. PRE-OPERATION PROCEDURES -Always connect ... P.18 10. SPECIFICATIONS -Power supply P.53	
2	Confirmation on operation	-Explain name and function of each component. -Start operation Set rotation speed at 100 rpm	2. COMPONENT NAMES AND FUNCTIONS P.8 4. OPERATION PROCEDURES P.32	
Description				
1	Operational descriptions	Explain operations of each component and handling precautions according to instruction manual.	4. OPERATION PROCEDURES P.32 5. HANDLING PRECAUTIONS P.44 -Warnings and Cautions 14. LIST OF HAZARDOUS SUBSTANCES P.62 -Table 14.1 List of ...	
2	Error Codes	Explain about error codes and procedures for reset according to instruction manual.	8. TROUBLESHOOTING -Reading Error Codes P.48 -Troubleshooting Guide P.50	
3	Maintenance and Inspection	Explain about maintenance of equipment and each component according to instruction manual.	6. MAINTENANCE PROCEDURES -Inspection and Maintenance P.46	
4	Completion of installation Matters to be Stated	- Enter the date of installation and name of the charged personnel in the main unit nameplate. - Write necessary information on warranty card and hand it over to customer - Explain how to contact with service personnel	9. SERVICE & REPAIR -Requests for Repair P.52	

Limited Liability

Always operate equipment in strict compliance to the handling and operation procedures set forth by this instruction manual.

Yamato Scientific Co., Ltd. assumes no responsibility for malfunction, damage, injury or death resulting from negligent equipment use.

Never attempt to disassemble, repair or perform any procedure which are not expressly mandated by this manual.

Doing so may result in equipment malfunction, serious personal injury or death.

Notice

- **Instruction manual descriptions and specifications are subject to change without notice.**
- **Yamato Scientific Co., Ltd. will replace flawed instruction manuals (pages missing, pages out of order, etc.) upon request.**

Instruction Manual
Rotary evaporator
REV202M series

First Edition: December 01, 2020

Revised: September 01, 2021

Yamato Scientific Co., Ltd.
Harumi Triton Square Office Tower Y (36F)
1-8-11 Harumi, Chuo-ku, Tokyo 104-6136, JAPAN

For repair service, maintenance service and consumables purchase support, please contact to our distributors from whom you purchased.

Or please visit to our customer support website at
<https://www.yamato-scientific.com/support/inquiry/>