



Muffle Furnace

FP103/303/313/413

Instruction Manual

First Edition

- Thank you for purchasing “Muffle Furnace FP series” of Yamato Scientific Co., Ltd.
- This product has not been designed for medical applications. Use this as a laboratory drying sterilizer only.
- In order to use this Equipment properly, please read this Instruction Manual and Warranty Card thoroughly before use. Keep them in safe place close to this Equipment so that you can refer to them any time.

 **Warning:** Please read the important warning notes in this Manual carefully and thoroughly, and get the good understanding of their contents before using this Equipment.

**Yamato Scientific America Inc.
Santa Clara, CA**

1. Safety Precautions	1
Explanation of symbols	1
List of symbols	2
Residual risk map.....	3
Residual risk list	4
List of residual risks.....	5
2. Before operating the Equipment	6
Precautions when installing the Equipment.....	6
3. Names and Functions of Parts	10
Main body.....	10
Structure diagram.....	11
Control Panel	12
4. Operating procedure	13
Prior confirmation	13
Date & Time setting.....	14
Buzzer function selection	15
Fixed temperature operation	17
Auto stop operation	21
Auto start operation	24
Program operation	27
How to copy or delete programs	37
About the wait function	39
Setting key lock mode	40
Calibration offset	41
Setting the recovery mode	42
Resetting integrated CO2 volume and CO2 emission factor	43
Backup data saving / reading out / resetting	45
Monitoring data	46
Independent Overheat Prevention Device	48
5. Handling precautions	50
Warning and caution	50
6. Maintenance method	54
Daily inspection/maintenance.....	54
Inspect monthly.	54
7. Long storage and scrap	55
When not using the Equipment for a long time / when scrapping	55
Matters to consider when scrapping the Equipment.....	55
8. When a trouble occurs	56
Message error table	56
Troubleshooting	58
9. After sales service and warranty	59

Request to repair parts	59
10. Specifications	60
Specifications	60
11. Accessory	62
List of accessories.....	62
List of optional settings.....	63
12. List of dangerous substances	64
13. Standard setup manual	65

1. Safety Precautions

Explanation of symbols

About symbols

Various symbols are provided in this Instruction Manual and on the product to ensure safe operation. Improper handling of this Equipment without understanding their contents will lead to the results classified below. Be sure to fully understand the description of symbols below before proceeding to the text of this Manual.

 **Warning** Indicates a situation which may result in death or serious injury (Note 1.)

 **Caution** Indicates a situation which may result in minor injury (Note 2) and property damages (Note 3.)

(Note 1) Serious injury means a wound, an electrical shock, a bone fracture or intoxication that may leave after effects or require hospitalization or outpatient visits for a long time

(Note 2) Minor injury means a wound or an electrical shock that does not require hospitalization or outpatient visits for a long time.

(Note 3) Property damage means damage to facilities, devices and buildings or other properties.

Meanings of symbols

 This symbol indicates a matter urging user to follow the warning ("caution" included).
Specific description of warning is indicated near this symbol.

 This symbol indicates prohibitions.
Specific prohibition is indicated near this symbol.

 This symbol indicates matters that the user must perform.
Specific instruction is indicated near this symbol.

1. Safety Precautions

List of symbols

Warning



General Warnings

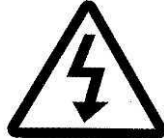

Danger!: High Voltage



Danger!: High Temperature



Danger!: Moving Part

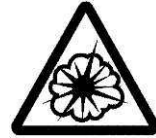

Danger!: Explosion Hazard

Caution



General Cautions



Caution: Electrical Shock!



Caution: Burns!



Caution: Heating Container without water!



Caution: Water Leak!



Caution: For water only



Caution: Toxic Chemicals

Prohibitions



General Prohibited Actions



No open flame



Do not disassemble



Do not touch

Compulsions



General Mandatory Actions



Connect grounding wire

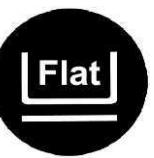

Leveled Installation



Disconnect Power



Regular Inspection

1. Safety Precautions

Residual risk map

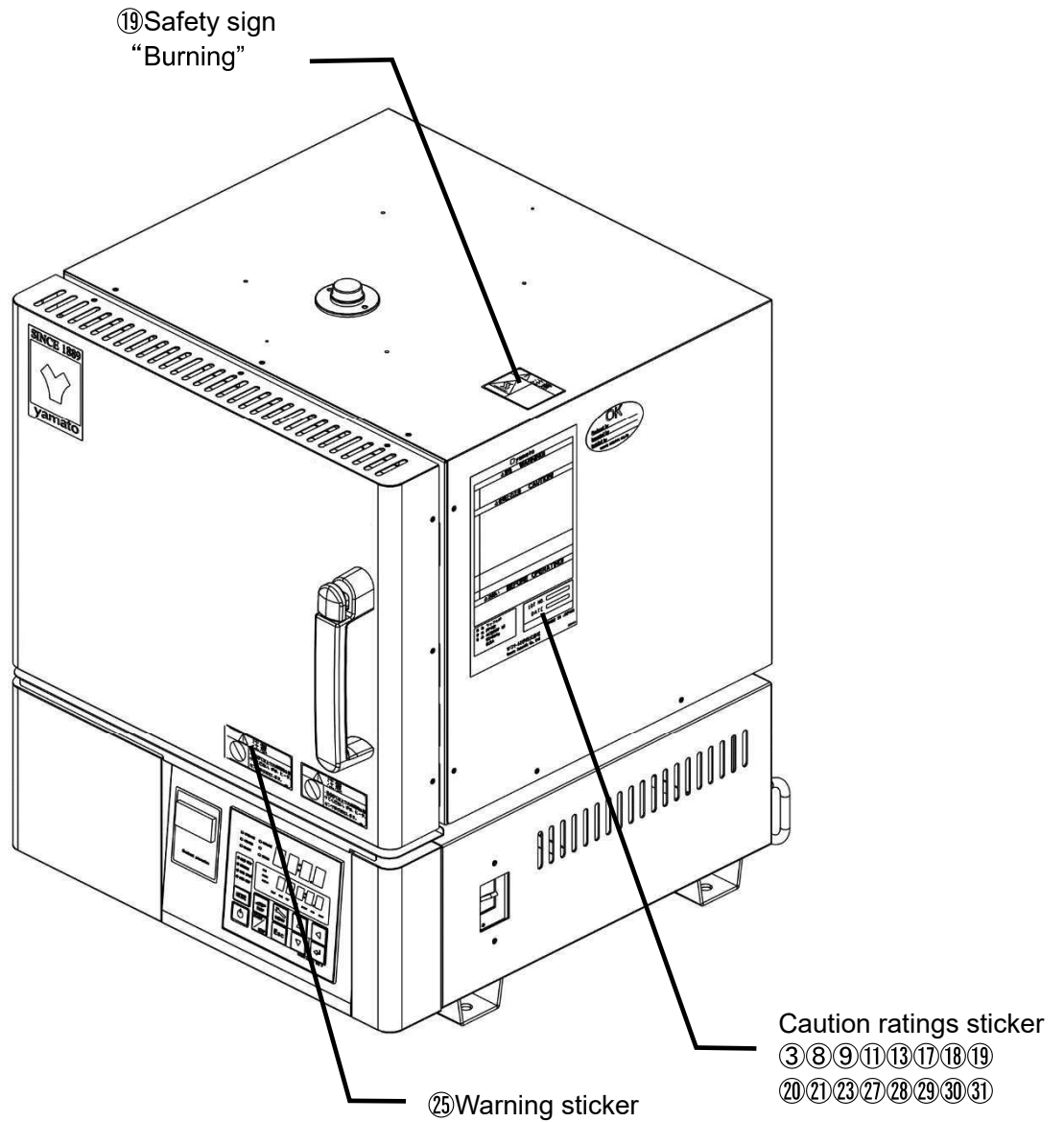

※Contact us when the caution texts are illegible because the nameplate has peeled off or characters are eliminated. We will send you a new name plate (for value).

1. Safety Precautions

Residual risk list

List of residual risks (Instructions for avoiding risks)

This list summarizes residual risks to avoid personal injuries or damages to properties during or related to the use of the product.

Be sure to fully understand or receive instructions on how to use, maintain and inspection of the product before starting operation.

During or on carrying-in or installation				
No.	Degree of risks	Details of risks	Protective measures to be implemented by the machine users	Relevant sections
(1)	Caution	Injury	Use cargo handling equipment for carrying and installation. Two or more people shall be necessary when transporting by humans.	Section 2.2
(2)	Warning	Fire or electrical shock	Carefully select an installation site and take care for the installation environment.	Section 2.1
(3)	Caution	Injury	Install on a level surface.	Section 2.2
(4)	Caution	Injury	Implement safety measures for installation.	Section 2.3
(5)	Caution	Injury	Implement appropriate safety measures after installation.	Section 2.4
(6)	Warning	Fire	Assure sufficient ventilation for the unit.	Section 2.5
(7)	Warning	Fire or electrical shock	Do not use the unit at a place that may be subject to splashes of liquid.	Section 2.6
(8)	Warning	Explosion or fire	Do not use the unit in a flammable or an explosive atmosphere.	Section 2.7
(9)	Warning	Fire or electrical shock	Connect the power supply to the dedicated distribution board.	Section 2.8
(10)	Warning	Fire or electrical shock	Take care for handling of the power cord.	Section 2.9
(11)	Warning	Fire or electrical shock	Be sure to connect the ground wire.	Section 2.10 Section 2.11
(12)	Warning	Fire or electrical shock	Do not disassemble nor modify the Equipment.	Section 2.12

During operation				
No.	Degree of risks	Details of risks	Protective measures to be implemented by the machine users	Relevant sections
(13)	Warning	Explosion and fire	Do not use an explosive or combustible substance.	Section 5.1
(14)	Warning	Fire	Do not use a resin container.	Section 5.9
(15)	Warning	Fire or electrical shock	Immediately turn the ELB off when an abnormality should occur.	Section 5.3
(16)	Warning	Fire, electrical shock or burning	Do not put any foreign objects in the unit.	Section 5.21
(17)	Warning	Burning	Take extreme care for handling of specimens after operation at a high temperature.	Section 5.15
(18)	Warning	Burning	Take extreme care when opening the door during operation at a high temperature.	Section 5.12 Section 5.13
(19)	Warning	Burning	Do not touch any hot surfaces.	Section 5.12 Section 5.15

1. Safety Precaution

List of residual risks

During operation				
No.	Degree of risks	Details of risks	Protective measures to be implemented by the machine users	Relevant sections
(20)	Caution	Injury	Do not attempt to climb on the unit.	Section 5.4
(21)	Caution	Injury	Do not put any objects on the unit.	Section 5.5
(22)	Warning	Fire	Do not use a unit with stacking on another unit.	Section 5.6
(23)	Warning	Fire	Turn the ELB off when thunder is heard.	Section 5.7
(24)	Caution	Burning and injury	Use the unit at the appropriate temperature (within the temperature control range).	Section 5.16
(25)	Warning	Burning	Take care for the temperature in the furnace after operation is completed.	Section 5.17
(26)	Warning	Fire Damage to the furnace body	Place specimens on the furnace floor plate.	Section 5.18
(27)	Warning	Fire and electrical shock	Take care for the handling of specimens.	Section 5.19
(28)	Warning	Fire	Make a temperature setting for the standalone overheat preventive unit.	Section 5.25
(29)	Warning	Injury	Take care not to allow your finger to be pinched in the fan at the back of the unit.	Section 5.28
(30)	Warning	Fire or electrical shock	Inspect the ELB and the standalone overheat preventive unit at regular intervals.	Section 5.29

During inspection and maintenance				
No.	Degree of risks	Details of risks	Protective measures to be implemented by the machine users	Relevant chapters
(31)	Warning	Fire or electrical shock	Remove the power cord before inspection or maintenance.	Chapter 6
(32)	Warning	Burning	Start maintenance only after the device has returned to the normal temperature.	Chapter 6
(33)	Warning	Fire or electrical shock	Do not attempt to disassembly the devices.	Chapter 6

When you are not going to use the unit for a long time or when discarding the unit				
No.	Degree of risks	Details of risks	Protective measures to be implemented by the machine users	Relevant chapters
(34)	Warning	Fire or electrical shock	Turn power off and remove the power cord.	Chapter 7
(35)	Caution	Injury	Do not leave the unit at a place where children may play.	Chapter 7
(36)	Caution	Injury	Remove the door apart to prevent it from closing before disposing of.	Chapter 7

2. Before operating the Equipment

Precautions when installing the Equipment

1. Choose proper place for installation



Do not install this Equipment in the place where:

- the location is rough, dirty or un-leveled.
- flammable gas, explosive gas or corrosive gas will be generated.
- Do not install unit in a place where exposed to the strong wind. Degraded performance, fire, or other accidents may result.
- ambient temperature will be more than 35°C or less than 5°C.
- ambient temperature will fluctuate.
- there is excessive humidity and dusty.
- there is constant vibration.
- power supply is instable.
- Busy places or other places that safety cannot always be assured.
- liquid may splash
- there is direct sunlight.
- outside the building.



Install the Equipment(s) at the place with sufficient space as specified as below

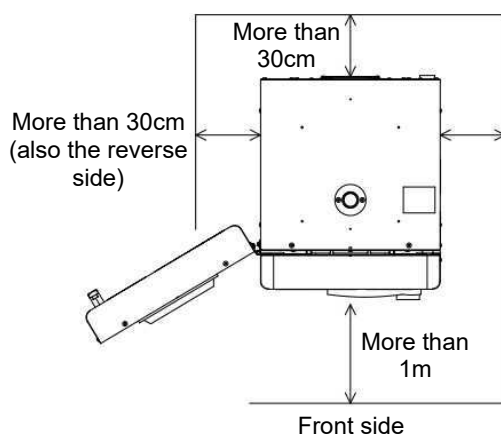

2. Install the Equipment on leveled location.



Install this Equipment on leveled floor. If it is installed on rough and/or slope floor, vibration or noise will be occurred, and unexpected trouble and malfunction may be happened.

Weight of this Equipment is as follows:

The container weight is approx. 32kg for FP103, approx. 50kg for FP303, approx. 43kg for FP313, and approx. 51kg for FP413.



Use cargo handling equipment for carrying and installation. Two or more people shall be necessary when transporting by humans.

3. Implement safety measures when installing the unit.



Earthquakes or unexpected shocks may cause the unit to fall or move and cause a personal injury. We recommend implementing safety measures such as installing the unit at a place with minimum traffic.

Some parts of the unit may be hot during operation. It is extremely dangerous to touch a hot surface, which may cause burning. We recommend installing appropriate fences around the installation site.

4. Implement appropriate safety measures after installation.



May be injured by moved and/or fallen this Equipment down by earthquake and/or unexpected impact.

Implement appropriate measures against falling down for safety.

2. Before operating the Equipment

Precautions when installing the Equipment

5. Ventilate sufficiently for the Equipment



Do not operate the Equipment blocked in the radiating slit holes-Louver on its side and back panels and top panel. Refer to 3. "Name and Functions of each part" on page 10 for the location of Louvers.

Internal temperature will rise, causing a malfunction of the controller to compromise the performance as well as to cause a possible accident or a fire.

6. Do not operate at the location of liquid splashing.



Do not operate this Equipment at the location of liquid splashing. If this Equipment will be wetted by splashing any kind of liquid, it may cause accident, electrical shock and/or fire.

7. Never operate in an atmosphere where flammable or explosive gas is present.



Never operate this Equipment in an atmosphere where flammable or explosive gas is present.

This Equipment is not explosion-proof. Spark may be discharged by switching Earth Leakage Breaker (ELB) "ON(|)" and "OFF(O)" and also relay during operation, and then it may cause fire or explosion. See Chapter 13. "List of Dangerous Substances" for flammable and explosive gases on page .69



Exercise extreme caution when heating test samples that may catch fire.

8. Connect Power Cord/Power Cable to receptacle or switch board of facilities.



Connect Power Cord/Power Cable to suitable receptacle/switch board of facilities according to electrical requirements as follows.

Electrical requirements:	FP103	AC115V single phase 50/60Hz	10A or more (ELB capacity; 15A)
	FP303	AC115V single phase 50/60Hz	21.5A or more (ELB capacity; 30A)
	FP313	AC220V single phase 50/60Hz	13.5A or more (ELB capacity; 15A)
	FP413	AC220V single phase 50/60Hz	18A or more (ELB capacity; 20A)

The operational voltage range is $\pm 10\%$, the voltage range where the specified performance is guaranteed is rating $\pm 5\%$, the frequency is rating $\pm 1\%$.

※ Check line voltage of its receptacle/switch board of facilities and/or whether utilize the same line with other equipments or not, if this Equipment does not start up/operate even to turn Earth Leakage Breaker (ELB) On (|). Take correct action for the solution, such as changing its power source away from other equipment.

※ The length of the power cord outside the unit is about 2m.

9. Take care for handling of the power cord.



- Never operate this Equipment at bundled Power Cord/Power Cable. May heat its Cord/Cable and then cause fire, if operate at bundled it.
- Do not modify, bend forcibly, twist or pull Power Cord/Power Cable. Otherwise, may cause fire and/or electrical shock.
- Do not connect too many wires to a branching tap or extend wires using a cord reel. Otherwise, heat is generated or a fire may result. Also, the voltage may drop or temperature control performance may be compromised.
- Do not damage Power Cord/Power Cable by setting under any desk and/or chairs, or by pinching it between objects. Otherwise, may cause fire and/or electrical shock.
- Do not place Power Cord/Power Cable close to kerosene heater, electric heater, or other heat-generating devices.



- Turn immediately off Earth Leakage Breaker (ELB) and also disconnect Power Plug/breaker of switch board of facilities, if it is damaged such as exposure of core wire or disconnection. May cause fire or electrical shock, if this Equipment is operated with damaged Power Cord/Power Cable.
- Connect Power Cord/Power Cable to appropriate receptacle or switch board of facilities.

2. Before operating the Equipment

Precautions when installing the Equipment

10. Must connect grounding wire properly. (FP103specification)



- Must connect grounding wire properly to grounding line or terminal in order to avoid electrical shock due to electrical leakage.
- Never connect grounding wire to gas line pipe or water line pipe due to fire or electrical shock.
- Never connect grounding wire to telephone grounding line or to lightning conductor due to fire or electrical shock.
- Never connect multiple plug to single receptacle due to generating heat dangerously.

Connect to grounded receptacle.

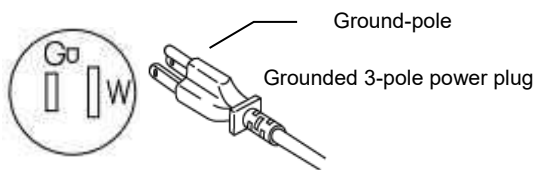

Receptacle with ground connection

Use grounded adaptor for ungrounded receptacle

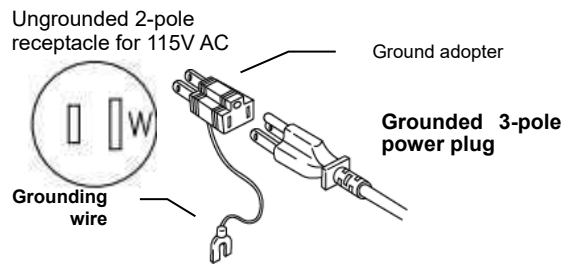

Ground adaptor

When there is no ground terminal.

●Require to ground by Electrical Equipment Technical Standards Section 19-calss D in Japan. Please contact with local dealer, local electrician, or Yamato Customer Service Center.

●Insert grounded power plug into ground adaptor. Connect grounding wire(green) of ground adaptor to ground terminal on switch board of facilities.

11. Must connect grounding wire properly. (FP303 FP313 FP413specification)



Require to ground by Electrical Equipment Technical Standards Section 19-calss D in Japan, if grounding terminal is not provided. Please contact with local dealer, local electrician, or Yamato Customer Service Center.

Connect the terminals firmly to switch board of facilities or appropriate power plug. Power plug itself will not be included as an accessory of this Equipment. Connect to the power supply facilities that meet the electric capacity.

FP303	AC115V single phase 50/60Hz	21.5A	or more (ELB capacity ; 30A)
FP313	AC220V single phase 50/60Hz	13.5A	or more (ELB capacity ; 15A)

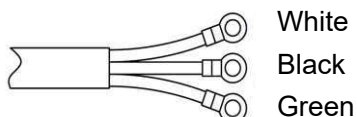

Core color	Wiring on the distribution board
White	Ground side
Black	Voltage side
Green	Earth



Never connect the ground wire to a gas pipe, a tap water pipe or a telephone line other than the ground terminal.
The product may not be grounded and an accident or a malfunction may result.

2. Before operating the Equipment

Precautions when installing the Equipment

12. Never disassemble nor modify the Equipment.



Never disassemble nor modify this Equipment. Those actions may cause this Equipment malfunction, fire or electric shock.

13. Place specimens on the furnace floor plate.



When placing specimens in the furnace, first put the floor plate on the bottom in the furnace on which specimens will be placed. Placing specimens directly may damage the furnace body or cause a fire.

3. Names and Functions of Parts

Main body

Outer appearance

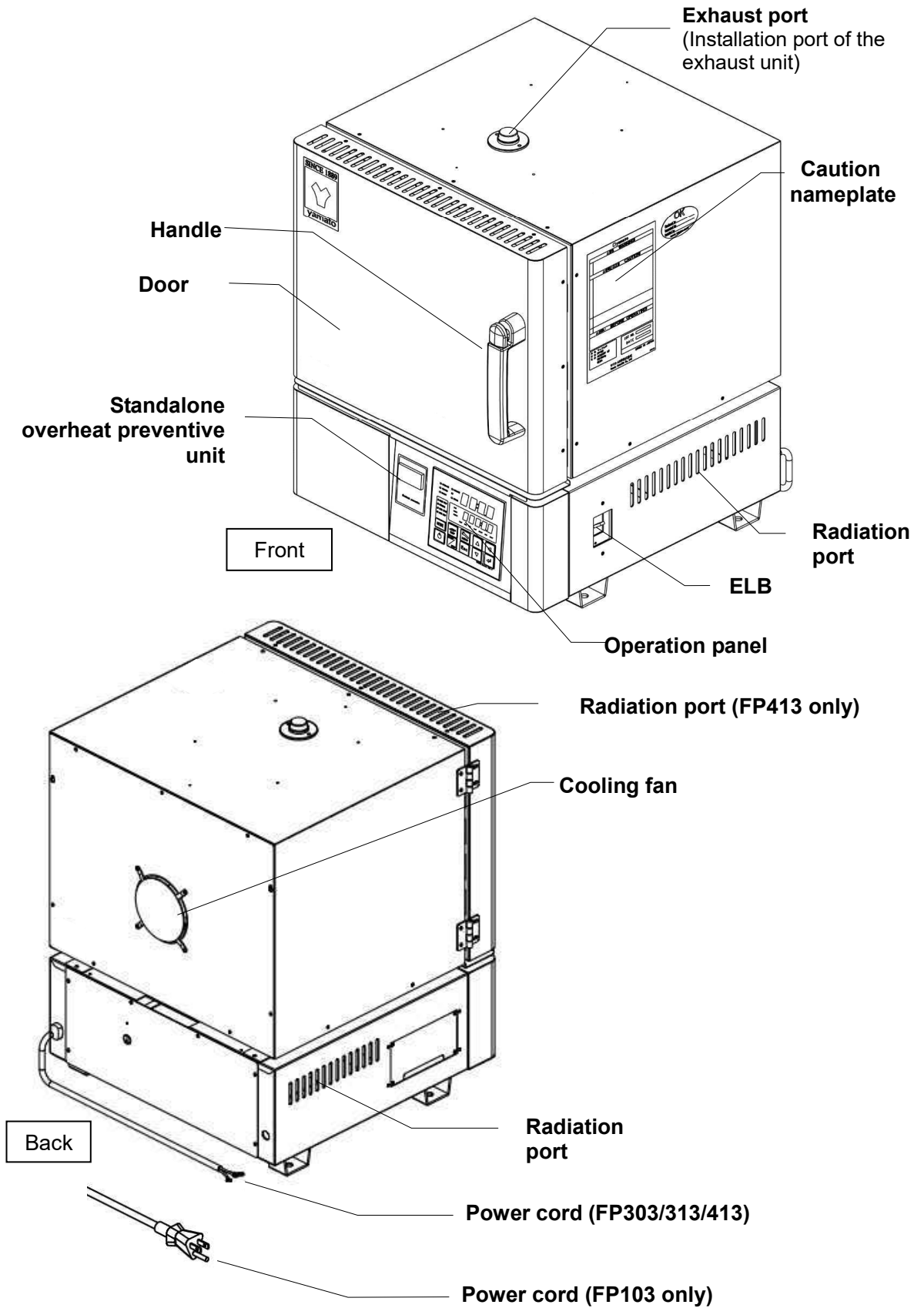

3. Names and Functions of Parts

Structure diagram

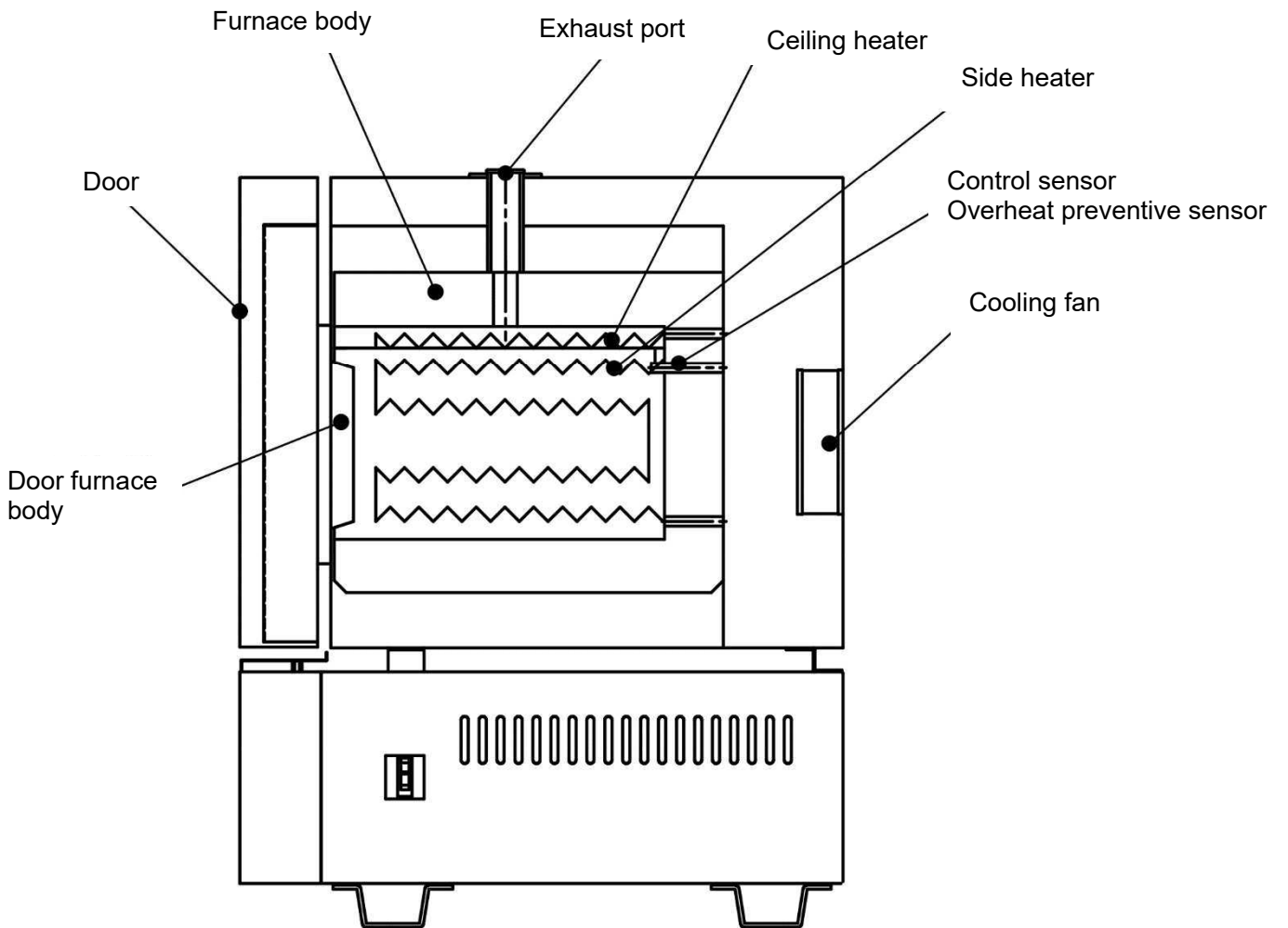

Side

3. Names and functions of each part

Control Panel

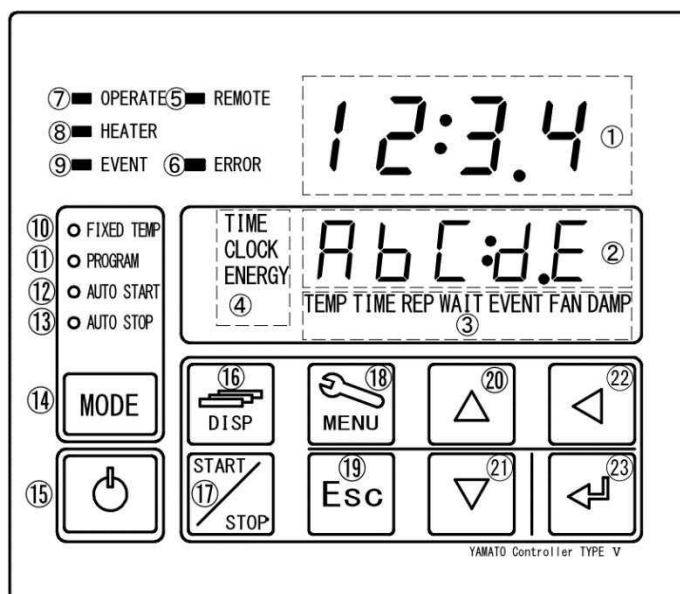

No	Name	Description
1	Top screen	Display read temperature in Furnace and error numbers.
2	Bottom screen	Display target temperature and various information.
3	Program setting item display	Illuminate one of lamps selected from different settings.
4	Comes on during duration/time setting and in the Monitoring mode	Illuminate one of lamps selected from 3(three) different settings.
5	REMOTE Lamp	Illuminate during control via communication
6	ERROR Lamp	Illuminate this Lamp at each error occurred.
7	OPERATE Lamp	Illuminate this Lamp during operation, and flash it during operation standby mode.
8	HEATER Lamp	Flashes or lights while the heater is live according to the operation amount.
9	EVENT Lamp	Illuminate this Lamp at Event Output setting(option).
10	FIXED TEMP Lamp	Illuminate while the fixed temperature operation mode is selected.
11	PROGRAM Lamp	Illuminate in the Program operation mode.
12	AUTO START Lamp	Illuminate in the Auto start mode.
13	AUTO STOP Lamp	Illuminate in the Auto stop mode.
14	MODE key	Use at changing Operation Mode among No. 10 thru. No.13(⑩~⑬ on the Panel).
15	Controller POWER key	Turn "Idle State"-(Controller is sleeping) or "Standby State"-(Controller is awaking) of Keys(except ⑱MENU Key) by pressing and holding this key.
16	DISP key	Keep this key pressed longer to execute the Monitoring function. This key functions as the back key for setting items while any of setting menus displayed.
17	START/STOP key	Use to start selected operation or to stop working operation.
18	MENU key	Use to set target program, click on/off, output temperature range(option), and etc.
19	Esc key	Use to abort or get out of working menu without entering and/or editing set value and items.
20	▲(Up) key	Use to change set value up.
21	▼(Down) key	Use to change set value down.
22	◀ key	Used as the Left key for the setting digits (cursor) during setting.
23	ENTER key	Use to enter set value and items.

4. Operating procedure

Prior confirmation

1. Check the power supply and the ground wire.



The specifications of the FP series are 115V and 220V.

Make sure to connect with this Equipment Power Cord/Power Cable to appropriate power source and to ground definitely.

2. Check the ELB.



Check if the ELB functions properly.

See "Maintenance method" on P.54 Chapter 6.

Check ELB performance once a month or before continuous long-term operation.

Tick current time on Bottom Screen of Control Panel at ELB ON(|).

3. Check the Independent Overheat Preventive device.



Make sure to set IOPD temperature more than 100°C higher of Target Temperature in the furnace.

Check IOPD performance before continuous long-term operation. Refer to "Independent Overheat Prevention Device" on page 48.

4. Operating procedure

Date & Time setting

The controller of this product keeps backup memory for customer settings including the calendar, timer settings, or operation programs using the built-in battery. This battery will hold data for about five years even if you turn power of the unit off. (Battery life will change depending on specific operating conditions.)

- ※ Contact with Yamato local dealer or Yamato Customer Service Center in case of replacing this battery. Make backup data file of the existing program data in case of being processed program mode. See “Backup data saving/reading out/resetting” on page 45.

Set up date & time properly in accordance with local time after replacing with new battery.

1 Turn on the controller.

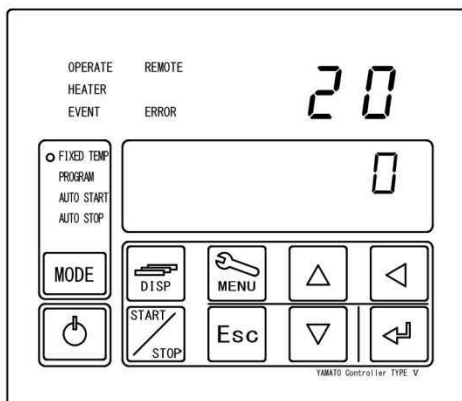

Turn on(|) Earth Leakage Breaker(ELB) on the right side of this Equipment.

Bottom Screen of the controller indicate clock time. This is “Idle State” of this Equipment.

Press and hold key to display standby screen. This is “Standby State” of this Equipment.

Indicate read temperature in Furnace on Top Screen and indicate target temperature on Bottom Screen. The fan motor will start.

2 Display year/month/date and time on each Screen by MENU key.

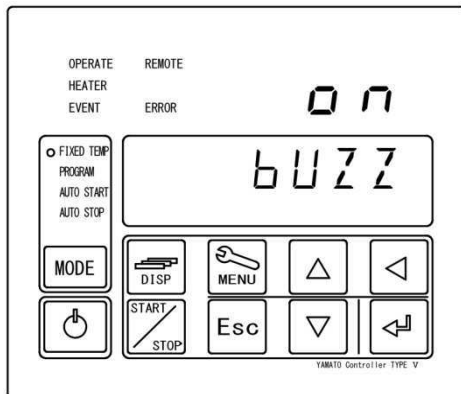

- ① Press key.
- ② Press key few times until [FUNC] is indicated on Bottom Screen and then press key.
- ③ Press key to display year on Top Screen and month/date/time on Bottom Screen, When Bottom Screen show [BUZZ].

The key can be used to reverse the process.

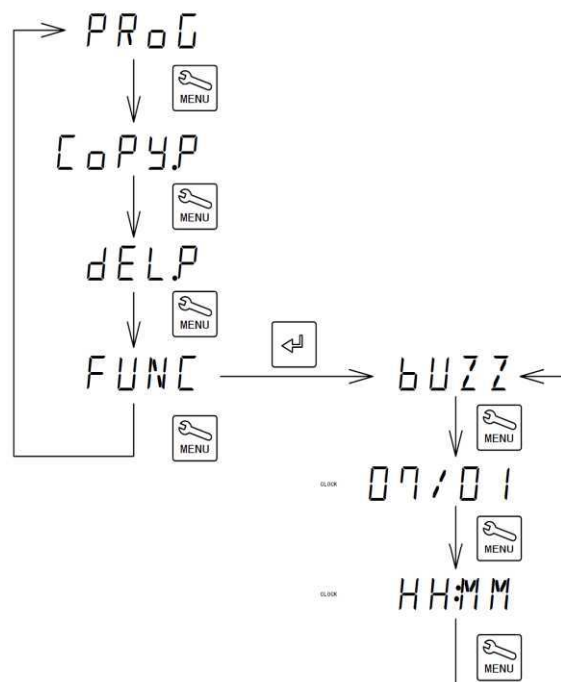

4. Operating procedure

Date & Time setting

3 Set up year and month/date.

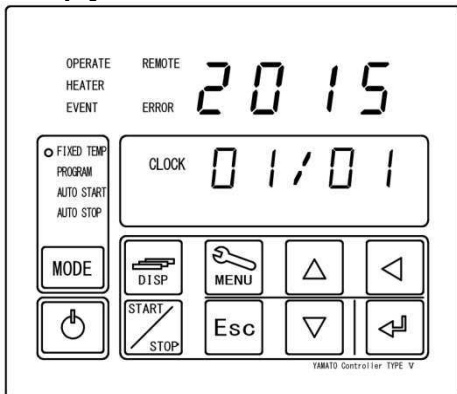

Set up year/month/date and clock time.

- ① Flash CLOCK lamp. Year and month/date are displayed on Top and Bottom Screen respectively.
- ② Press key.
- ③ Set calendar year with keys and then press key.
- ④ Set month/date with keys and then press key.

※ Press key to shift setting position.

4 Set up clock time (described according to 24-hour time).

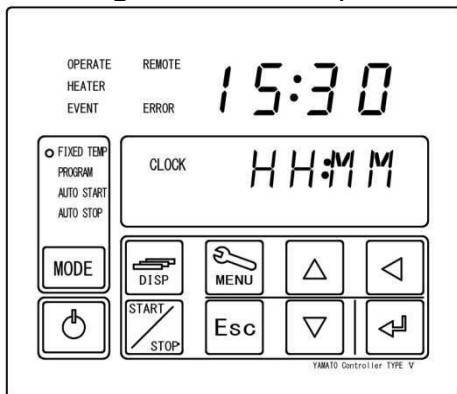

- ① Press key.
- ② Press key, set clock time with keys, and then press key.
Enter clock time in accordance with 24-hour time.

※ Press key to shift setting position.

- ③ Press key twice to get back to initial screen after completion of those settings.

Buzzer function selection

1 Select buzzer function.

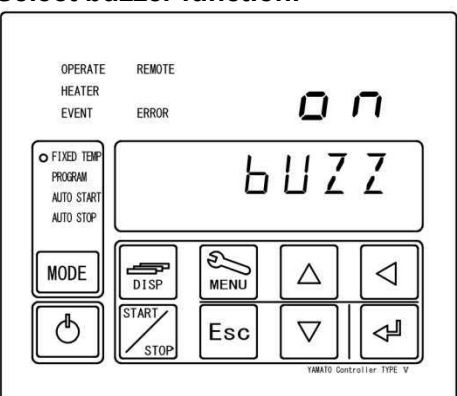

- ① Press key and key to display [bUZZ] on Bottom Screen with same process of clock time setting described in [2], and then press key.

- ② Select one from three types of buzzer function with keys and then press key.

ON: Activate clicking sound for all keys and beeping sound for alarm. (Set "on" initially at Factory shipment)

CLF : Activate only clicking sound for "Controller POWER key and ENTER key", and beeping sound for alarm.

OFF: Deactivate clicking sound for all keys.

※ The buzzer will sound when an error occurs even if you set "bUZZ" to a setting other than ON.

- ③ Press key twice to get back to initial screen after completion of those settings.

4. Operating procedure

Operating procedure

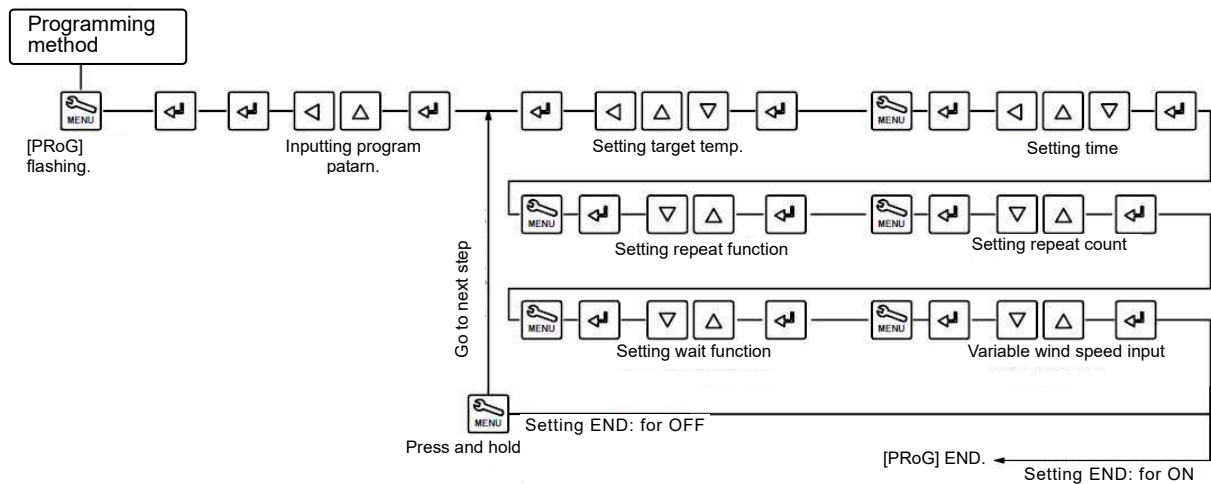
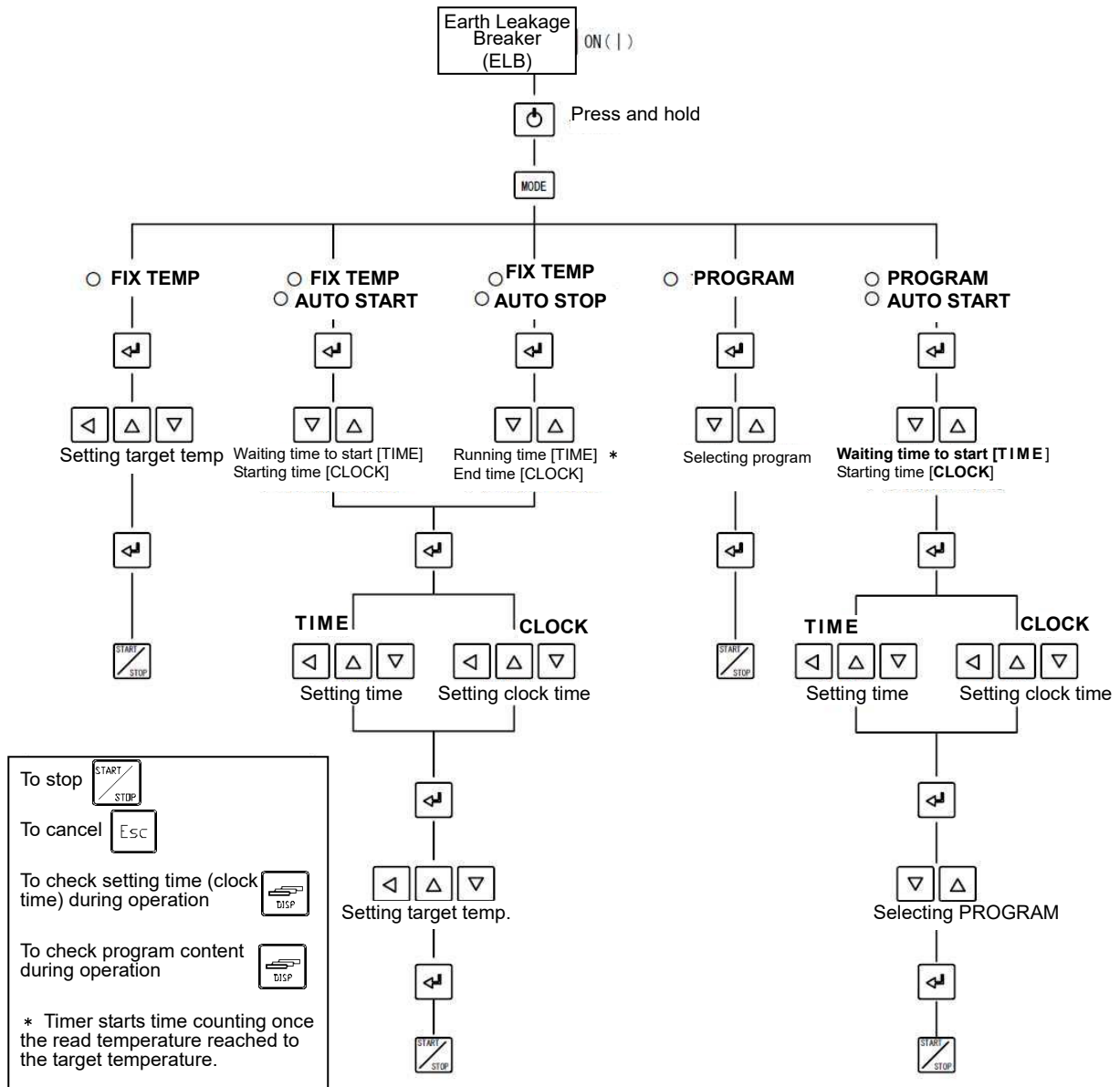

4. Operating procedure

Fixed temperature operation

FIXED TEMP (Fixed Temperature) mode is to keep running at target temperature. It will keep running until operation stops.

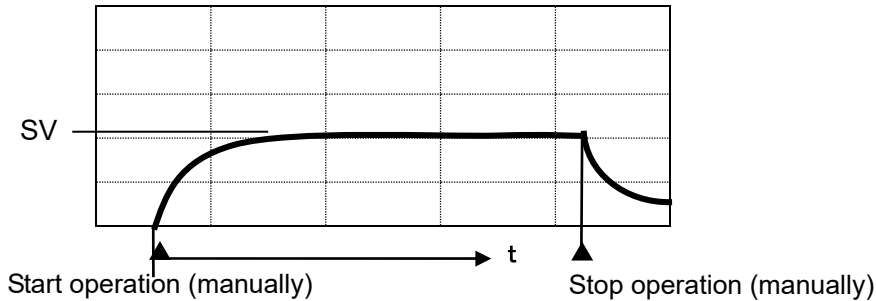

SV: Set Value (Target Temperature), t: Time

Set Fixed Temperature mode.

1 Turn on the controller.

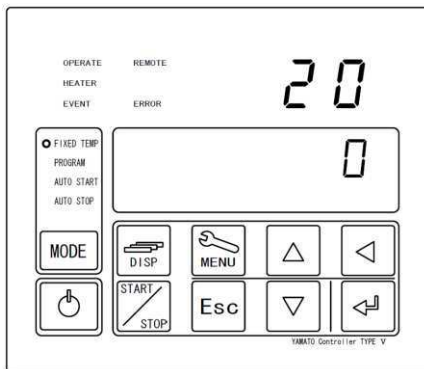

Turn on Earth Leakage Breaker(ELB) on (|) the left side wall of this Equipment. (**Idle State**)

Press and hold key to turn on the controller power. (**Standby State**)

Indicate read temperature in Furnace on Top Screen and indicate target temperature on Bottom Screen. The fan motor will start.

2 Set to the fixed temperature mode.

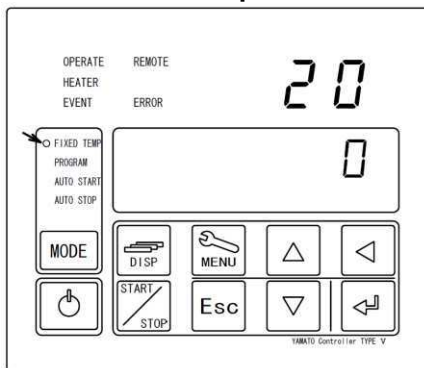

Press key to turn FIXED TEMP (Fixed Temperature mode) lamp on.

※ Fixed Temperature mode would be selected at first time operation. After that, most latest operated mode is selected.

3 Set a temperature.

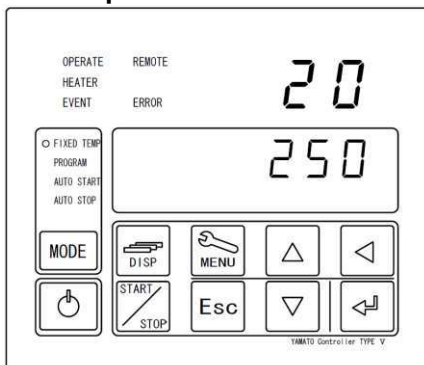

① Press key. Then flash changeable digits on Bottom Screen.

② Shift to flashing digit with key and then change to desired digit with keys.

Operating Temperature Range : 0~1200°C
(FP103/303/313/413)

③ Press key when target temperature setting has completed.

Press key once or twice to cancel its setting.

4. Operating procedure

Fixed temperature operation

4 Starting operation

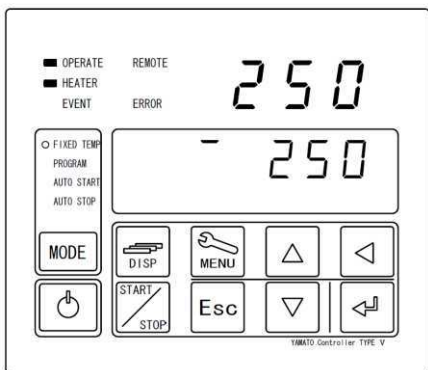
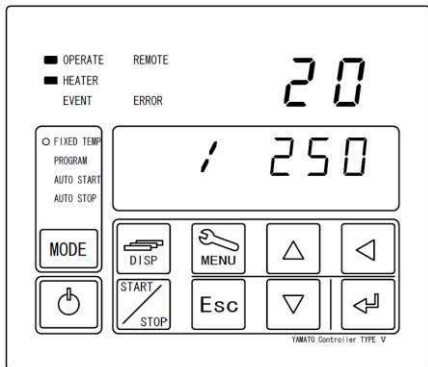

Use the  key to start operation.

The OPERATE (operating) lamp and the HEATER (heater) lamp will come on and temperature control starts.

※ Bottom screen during heating



※ Bottom screen while temperature is stable

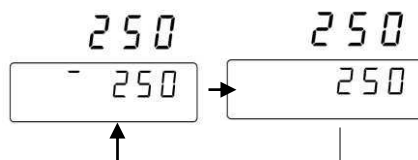

※ Bottom screen while temperature is decreasing



5 Stopping operation

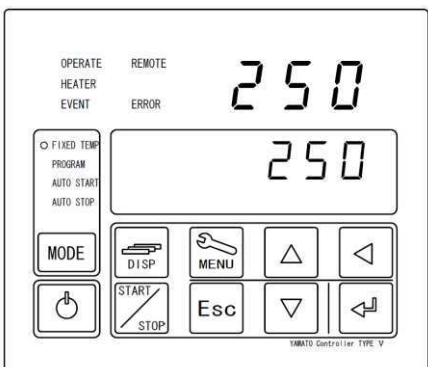

Use the  key to manually stop operation.

The screen will return to the one before starting operation when you stop operation.

4. Operating procedure

Fixed temperature operation

6 Stop running Fixed Temperature Operation with timer setting. (Quick Automatic Stop Function)

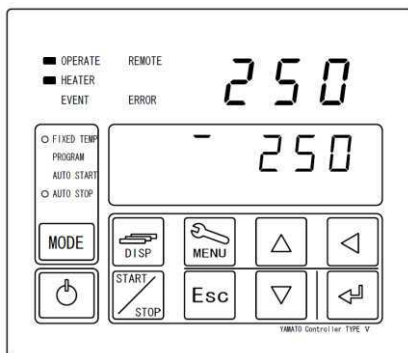
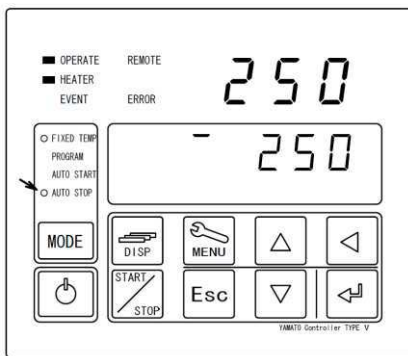
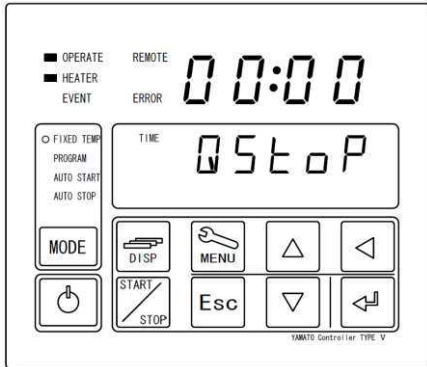

Quick Automatic Stop Function is to stop automatically running Fixed Temperature Operation.

- ① Press **MODE** key at running Fixed Temperature operation.
- ② Show **[QSTOP]** on Bottom Screen and start **[TIME]** lamp flashing on the left top of Bottom Screen.
- ③ Select the method to stop from **TIME/CLOCK** with **△**/**▽** key and then press **↵** key.
- ④ Set **TIME** (capable setting range: 0~99hr : 59min) or **CLOCK** (according to 24-hour time) on Top Screen and then press **↵** key.

Example 1. Setting time to stop:

Operation is stopped automatically in 35 hours and 30 minutes once temperature reached to target temperature.

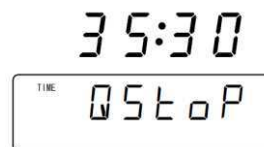

Example 2. Setting clock time to stop:

Operation is stopped automatically at 15:00.

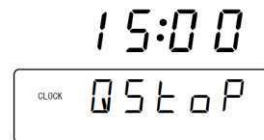

- ⑤ The **AUTO STOP** (Auto Stop) lamp comes on and the Auto Stop function starts.

You can use the **DISP** key to check the remaining operation time/stop time information on the Bottom screen.

Screen to check the remaining operation time

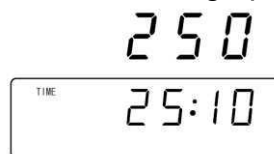

※ Screen to check the operation stop time

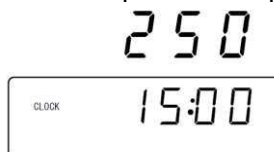

Press the **DISP** key again or wait for about 10 seconds to return to the original status.

4. Operating procedure

Fixed temperature operation

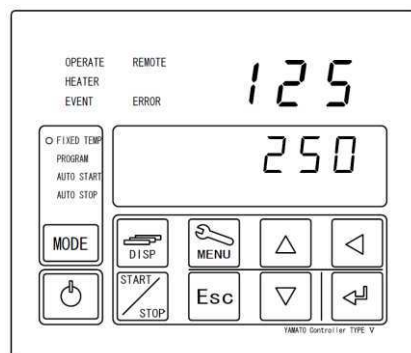
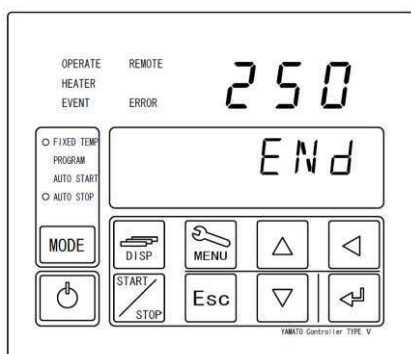

⑥ When the set time duration elapses or the time comes, the Bottom screen will indicate [END] and operation will stop.

⑦ Use the  key to eliminate the [END] indication.

※ When you stop operation, the screen will return to the one before starting operation.

4. Operating procedure

Auto stop operation

This operation mode is used to automatically stop operation by setting the timer.

The operation mode where operation is automatically stopped by setting an operation duration.(when you set an operation duration)

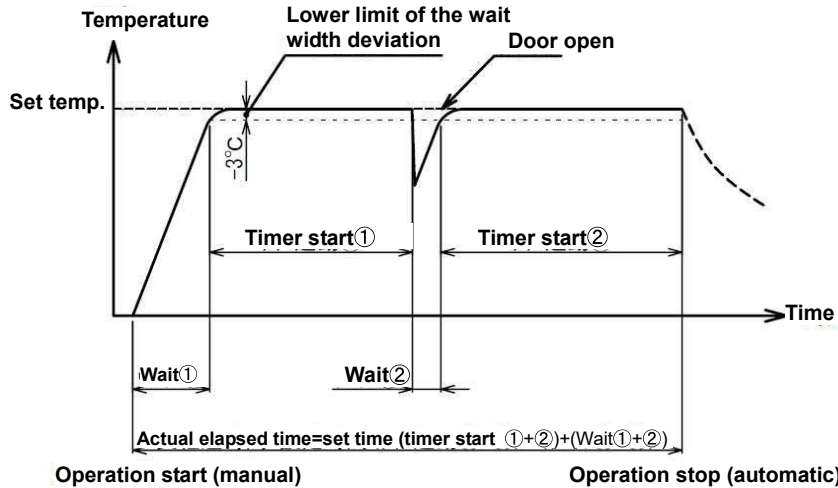

※ When you set a time, the wait function will be activated, the mode will remain “waiting” without counting down the time until temperature indication will be within the wait deviation range between -3°C and +6°C to the set temperature. Counting down starts when the temperature in the furnace reaches the temperature -3°C (indication) to the set temperature.

Even if the temperature in the furnace (indication) the mode will be “waiting” if the lower limit of the wait width deviation is exceeded and time counting down will not occur until the temperature in the furnace (indication) returns.

Operation mode where operation stops automatically at the set time (when an operation time is set)

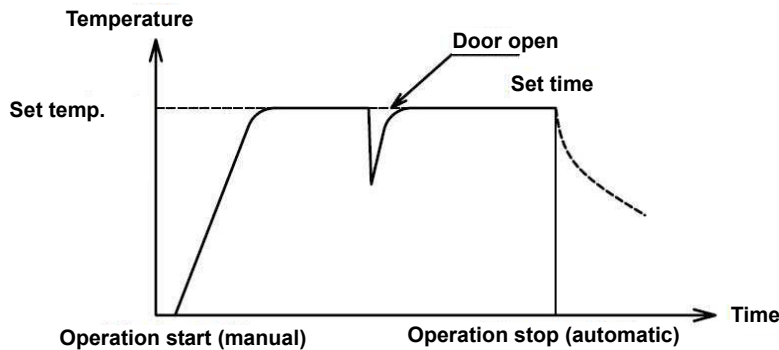

※ The wait function will not work if you select a time setting. Operation will stop when the set time comes. The time you can set is up to 24 hours from the present time.

When a power failure occurred before the set time and continued after that and then the unit recovered automatically, operation will continue to the next set time so remember to stop operation manually.

Set Automatic Stop mode

1 Turn on the controller

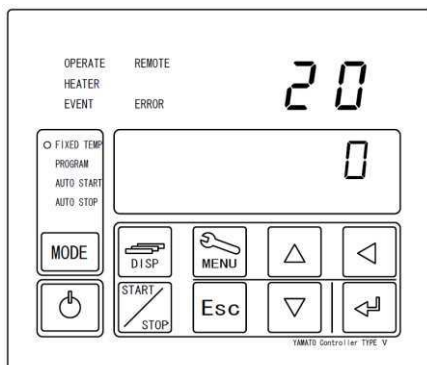

Turn on(|) Earth Leakage Breaker (ELB) on the upper right side wall of this Equipment. (**Idle State**)

Press and hold  key to turn on the controller power.

Indicate circulating liquid temperature in Furnace on Top Screen and indicate target temperature on Bottom Screen.

4. Operating procedure

Auto stop operation

2 Selecting Automatic stop Operation

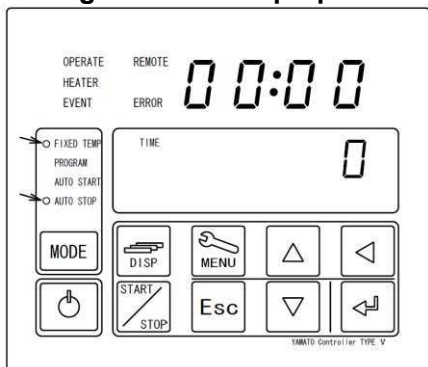

Press **MODE** key to turn FIXED TEMP (Fixed Temperature mode) and AUTO STOP (Automatic Stop mode) lamp on.

※ Fixed Temperature mode would be selected at first time operation. After that, the latest operated mode is selected.

3 Set target temperature and operation running time / clock time to stop.

- ① Press **←** key.
Select stop method from TIME/CLOCK with **△** **▽** keys and then press **←** key.
- ② Set TIME (capable setting range: 0~99hr : 59min) or CLOCK (according to 24-hour time) on Top Screen and then press **←** key.
- ③ Set target temperature on Bottom Screen and then press **←** key.

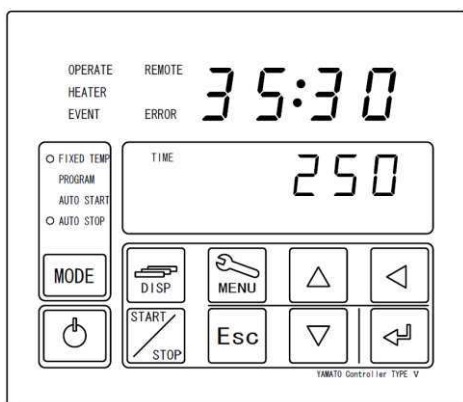

Example 1. Setting running time:
Operation is stopped automatically in 35 hours and 30 minutes once temperature reached to 250 °C of target temperature.

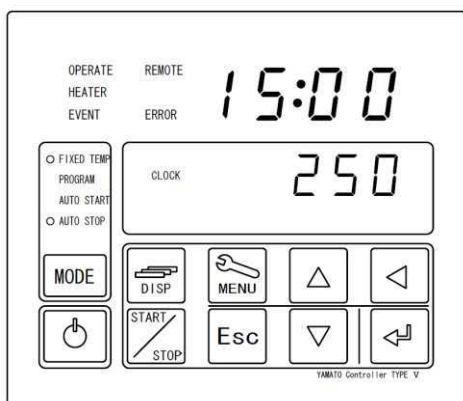

Example 2. Setting clock time to stop:
Start operation and reach to 250°C in Furnace of target temperature, and operation is stopped automatically at 15:00.

4. Operating procedure

Auto stop operation

4 Starting operation

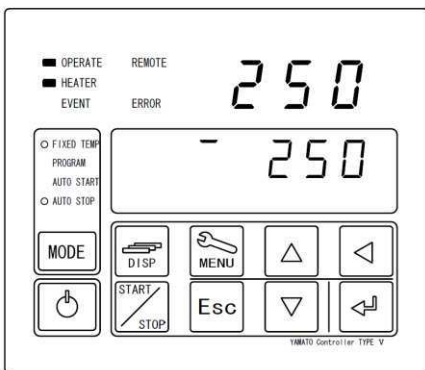

- ① Use the  key to start operation.

The OPERATE (operating) lamp and the HEATER (heater) lamp will come on and temperature control starts.

- ※ You can use the  key to check the remaining operation time/stop time information on the Bottom screen.

- ※ Screen to check the remaining operation time

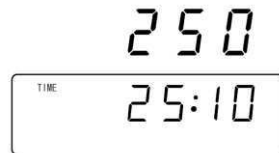

- ※ Screen to check the operation stop time

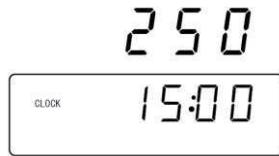

Press the  key again or wait for about 10 seconds to return to the original status.

5 Cancelling operation

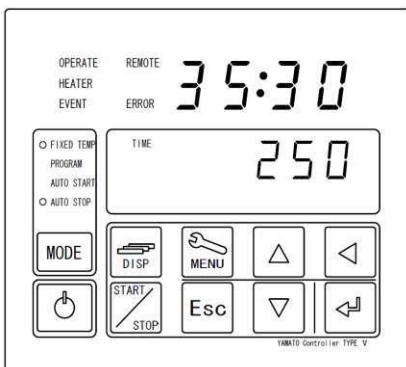
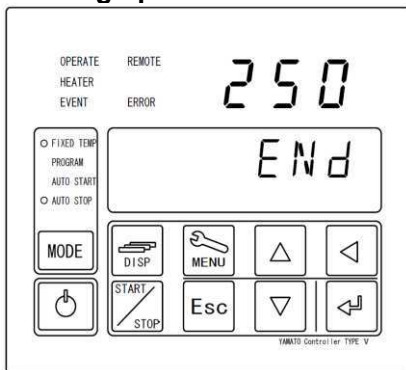

- ① When the set time duration elapses or the time comes, the Bottom screen will indicate [END] and operation will stop.

- ② Press the  key to eliminate the [END] indication.

- ※ When you stop operation, the screen will return to the one before starting operation.

4. Operating procedure

Auto start operation

AUTO START (Automatic Start) mode is to start operation automatically with timer. This operation does not stop automatically once its start. Stop manually, if required.

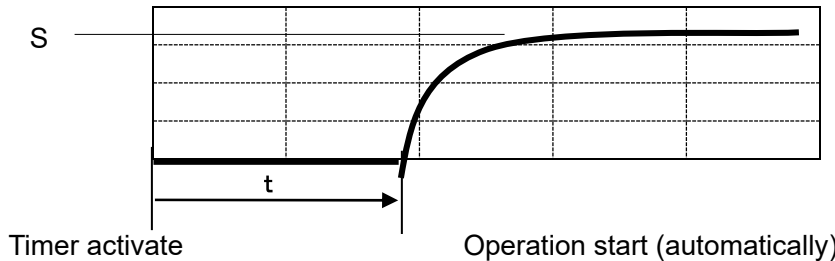

SV ; Target temperature t ; Auto start setting time (time)

Set Automatic Start mode

1 Turn on the controller.

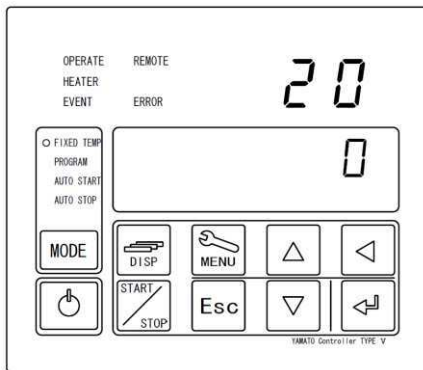

Turn on (|) Earth Leakage Breaker (ELB) on the right side wall of this Equipment. (**Idle State**)

Press and hold key to turn on the controller power. (**Standby State**)

Indicate circulating liquid temperature in the furnace on Top Screen and indicate target temperature on Bottom Screen.

2 Select Automatic Start mode

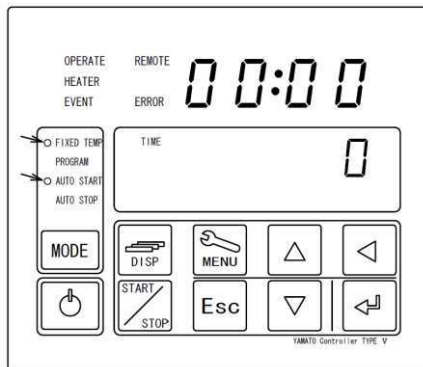

Press key to turn FIXED TEMP (Fixed Temperature mode) and AUTO START (Automatic Start mode) lamp on.

※ Fixed Temperature mode would be selected at first time operation. After that, the latest operated mode is selected.

3 Set target temperature and operation wait time / clock time to start

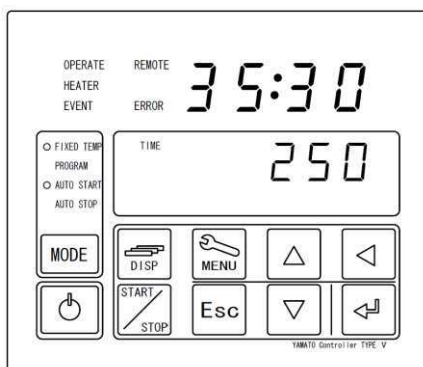

① Press key. Select start method from TIME/CLOCK with keys and then press key.

② Set TIME (capable setting range: 0 ~ 99hr : 59min) or CLOCK (according to 24-hour time) on Top Screen and then press key.

③ Set target temperature on Bottom Screen and then press key.

4. Operating procedure

Auto start operation

Example 1. Setting wait time to start:

Press  key to count timer for 35 hours and 30 minutes, and then start automatically operation to reach to 250°C of target temperature in

35:30

TIME 250

Example 2. Setting clock time to start:



Press  key to start automatically operation to reach to 250°C of target at temperature at 15:00.

15:00

CLOCK 250

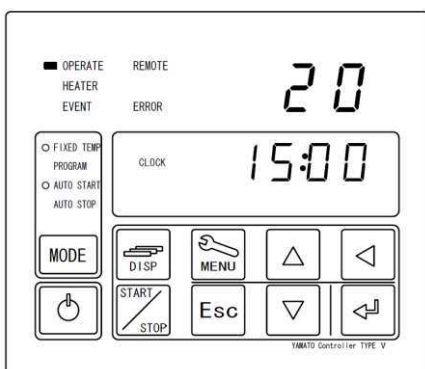
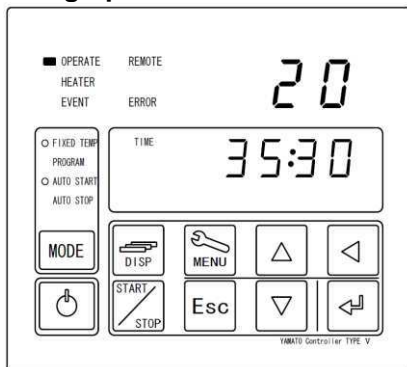
4 Starting operation



- ① Press  key to be standby mode for starting operation.
- ② Press  key to be standby mode for starting operation.

※ The Top screen shows the present temperature in the furnace while the Bottom screens shows the operation wait duration and the operation start time. When you have selected a wait time, counting down of the set time starts.

20

TIME 25:37

※ You can check the set temperature on the Bottom screen using the  key.

20

250

Pressing the  key again will make the Bottom screen show the operation wait duration and the operation start time.

4. Operating procedure

Auto start operation

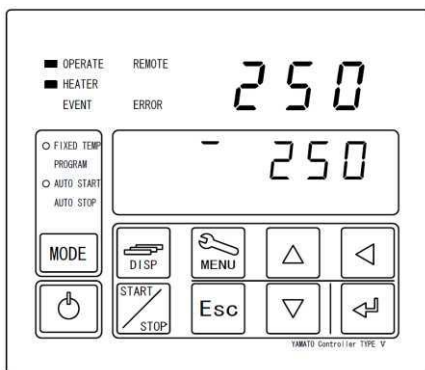
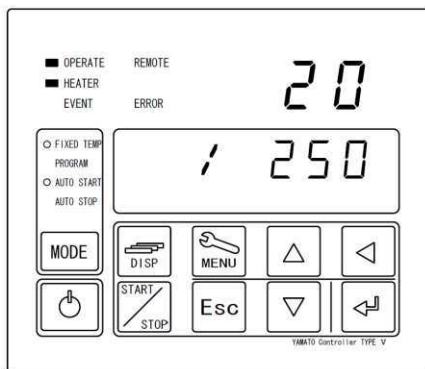

- ③ When the set time duration elapses or the time comes, the OPERATE (Operating) lamp will change its status from flashing to staying on as well as the HEATER (Heater) lamp comes on and temperature control will start.

※ You cannot use the Quick auto stop function for the Auto start operation.

5 Stopping operation

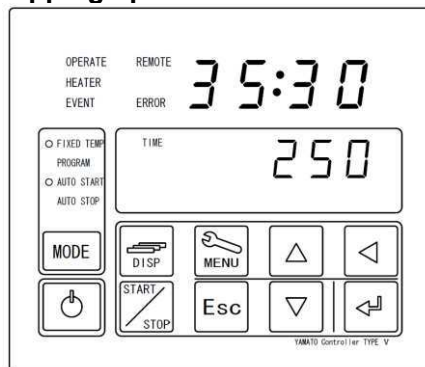

Use the  key to manually stop operation. The screen will return to the one before starting operation when you stop operation.

4. Operating procedure

Program operation

PROGRAM mode is to run programmed cycle such as figure below.

Setting temperature

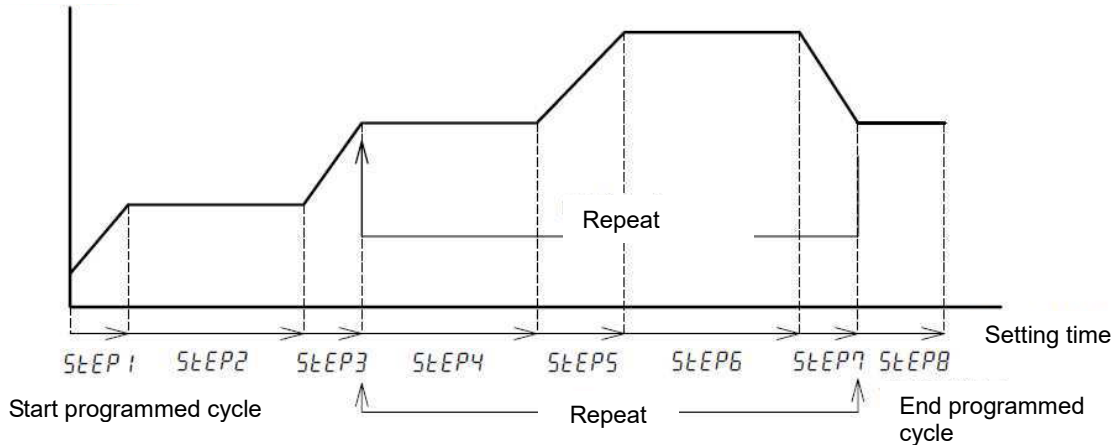

Setting the program operation

1 Turning on the controller

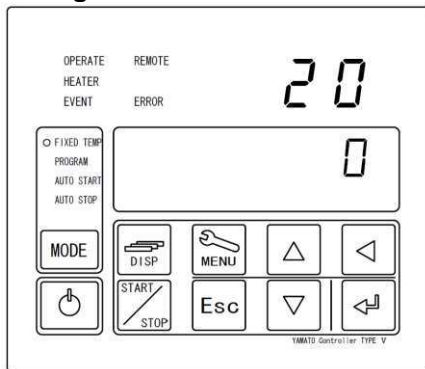

Turn the ELB on the left side of the main unit [ON(|)]. Pressing the  key longer will turn the controller power on.

The Top screen shows the temperature in the furnace while the Bottom screen shows the set temperature.

* Register target program prior to start running cycle at first.

For how to register a program, see "P.30 Programming method".

Create as many as steps up to 99 at maximum and save programmed pattern data up to 99 in total. (For example: 11 program patterns will be stored at maximum, if each pattern is programmed 9 steps. The number of steps in the repeat interval will be the number of the steps set in the registration part irrespective of the number of repetitions.)

2 Select program mode

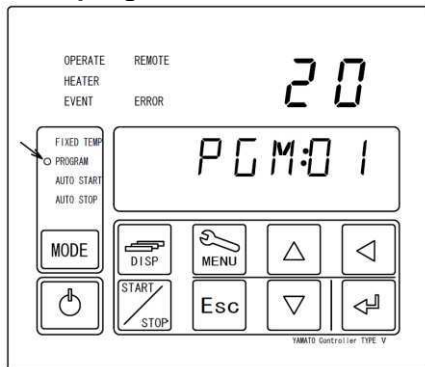

Press  key to turn PROGRAM Lamp on.

The bottom screen shows [PGM:01] ([01] indicates a program you used in the last session.)

※ Fixed Temperature mode would be selected at first time operation. After that, the latest operated mode is selected.

4. Operating procedure

Program operation

3 Select program patter number

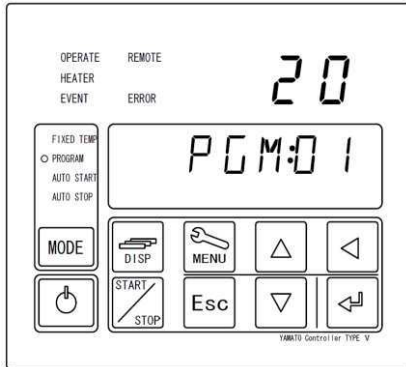

Press key. 01, a part of [PGM:01], is flashing on Bottom Screen. Select particular number of desired program pattern with keys and then press key.

4 Start program mode

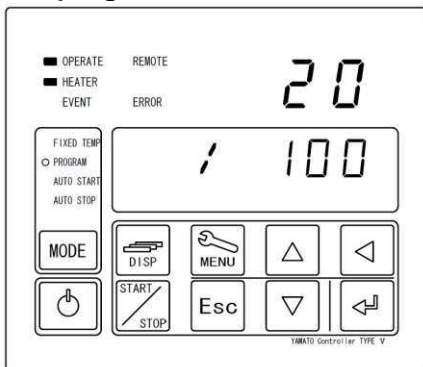

Press key to start programmed cycle operation.

- ※ Never run its cycle if [END] is not set at the end step in the program. Check again that program setting, if cycle do not start.
- ※ You can check the program pattern number, the step number or the remaining operation time being executed on the Bottom screen with the key during operation.
- ※ Screen to check the number of a program pattern being executed.

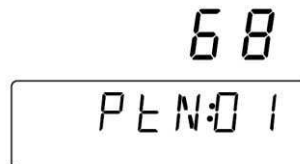

- ※ Screen to check the number of a program step being executed.

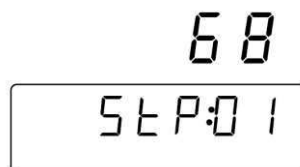

- ※ Screen to check the remaining time of a step being executed.



4. Operating procedure

Program operation

5 Cancelling program operation

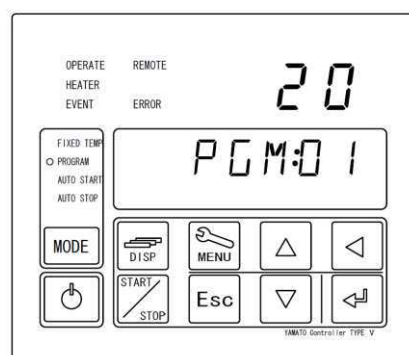
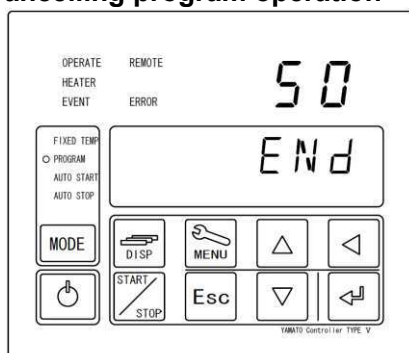

① When the set program ends, the Bottom screen shows [END] and operation will stop.

② You can eliminate the [END] indication using the  key.

※ The screen will return to the one before starting operation when you stop operation.

4. Operating procedure

Programming Method

Sample program setting

In this example, 8 steps are registered in the program pattern 2, steps from 4 to 7 will be repeated 5 times and the whole session will end at the step 8.

Note: Steps 4 to 7 will be repeated 6 times.

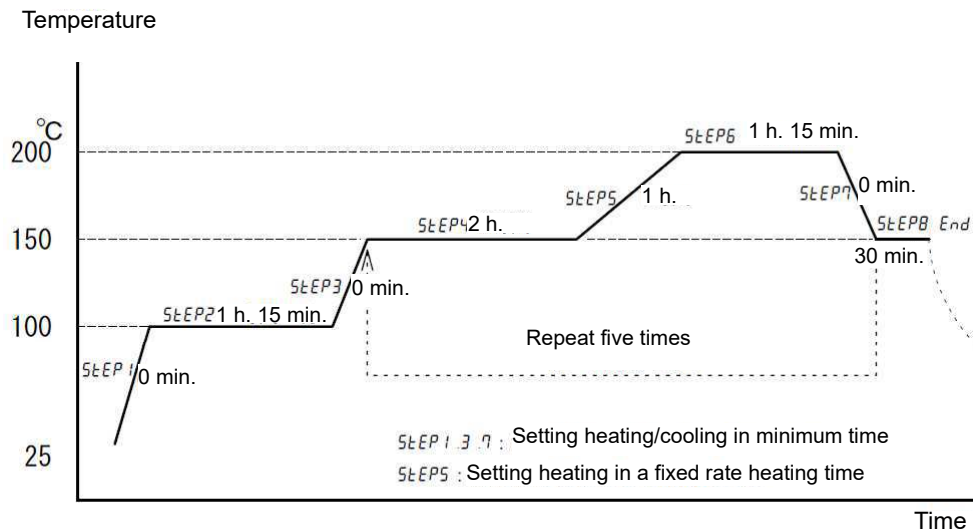

Pattern No	Step	Set temp.	Set time	Repeat dstn.	Repeat No.	Wait	End
P** :01	P02: **	TEMP	TIME	REP(STEP)	REP(COUNT)	WAIT	ENDST
02	01	100	00:00	0	0	ON	OFF
	02	100	01:15	0	0	OFF	OFF
	03	150	00:00	0	0	ON	OFF
	04	150	02:00	0	0	OFF	OFF
	05	200	01:00	0	0	ON	OFF
	06	200	01:30	0	0	OFF	OFF
	07	150	00:00	4	5	ON	OFF
	08	150	00:30	0	0	OFF	ON

- ※ When set time for heating or cooling steps beyond the heating or the cooling capacity (0 minute in the example) of the unit, it will operate at the full power for a short time at wait [ON]. At wait [OFF], the step will proceed to the next one irrespective of whether the set temperature is attained or not and you need to take care for setting a wait for heating or cooling for a short period.
- ※ If you set a time beyond the beyond the temperature increase and decrease time, temperature increase and decrease will be controlled at the specified rate so that the set temperature will be attained in the set time.
- ※ If you set operation with temperature increase or decrease in the program operation, temperature increase and decrease operation will be carried out at the specified rate from the current temperature to the set temperature for the set time. With the wait "ON" setting, the step will proceed to the next one when the measured temperature is within the wait range. With the wait "OFF" setting, the step will proceed to the next one when the set time elapses irrespective of whether the set temperature is reached or not.







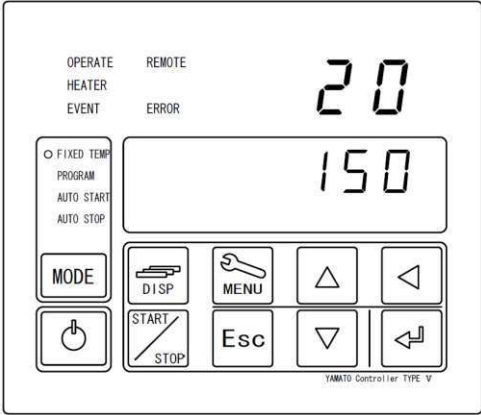

4. Operating procedure

Programming Method

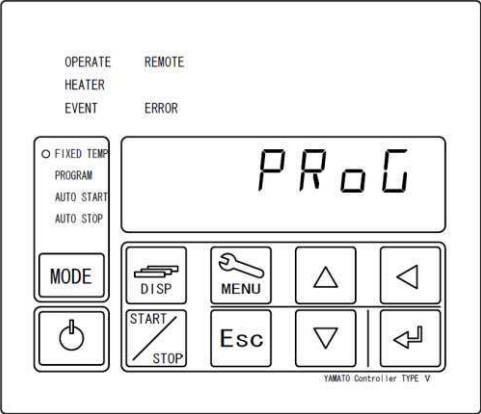
- ※ When a fixed temperature step is set and wait is [**ON**], the wait mode will continue from the time when the temperature in the furnace drops below the lower limit of the wait width deviation temperature due to, for example, opening of the door until the temperature in the furnace will recover above that lower limit. At [**OFF**] the process will proceed to the next step after the set time irrespective of changes of the temperature in the furnace.
- ※ When you use the repeat function, program the operation so that the set temperature before shifting to the repeat mode will be the same as the set temperature of the destination of repetition.
- ※ Checking the heating capacity and the cooling capacity before setting is encouraged since these will differ depending on the environmental temperature and the operating conditions.

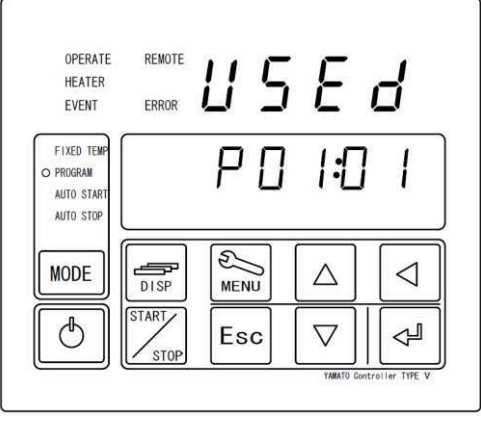

















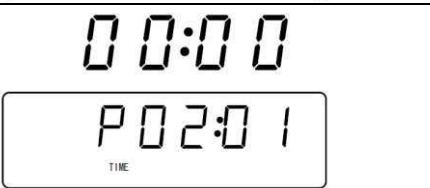







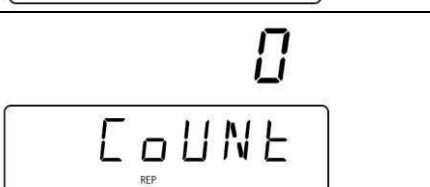







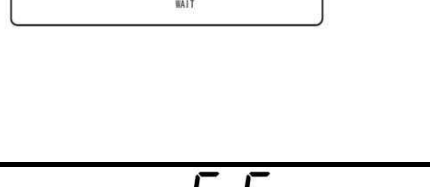

4. Operating procedure

Programming Method

NO	Indication	Operating procedure
I	 <p>OPERATE REMOTE HEATER ERROR EVENT</p> <p>20</p> <p>150</p> <p>○ FIXED TEMP PROGRAM AUTO START AUTO STOP</p> <p>MODE</p> <p>DISP MENU</p> <p>START STOP Esc</p> <p>YAMATO Controller TYPE V</p>	
II	 <p>OPERATE REMOTE HEATER ERROR EVENT</p> <p>PRoG</p> <p>○ FIXED TEMP PROGRAM AUTO START AUTO STOP</p> <p>MODE</p> <p>DISP MENU</p> <p>START STOP Esc</p> <p>YAMATO Controller TYPE V</p>	<p>[PROG] flashes.</p> 
III	 <p>OPERATE REMOTE HEATER ERROR EVENT</p> <p>USED</p> <p>P01:01</p> <p>○ FIXED TEMP PROGRAM AUTO START AUTO STOP</p> <p>MODE</p> <p>DISP MENU</p> <p>START STOP Esc</p> <p>YAMATO Controller TYPE V</p>	<p>○ The PROGRAM lamp flashes.</p> <p>[USED] means that the program has already been registered.</p> <p> [1] of P01:01 flashes.</p> <p> Makes [1] of P01:01 flash.</p> <p> Input as [P02:01].</p>
1-1	<p>Inputting [P02: * *] of program pattern 02</p> <p>-----</p> <p>P02:01</p>	<p>[2] of P02:01 flashes and the Top screen shows [-----] which means any programs are not registered.</p>





























4. Operating procedure

Programming Method

<p>1-2</p> 	<p>Input pattern 02, STEP 01.</p>  TEMP flashes.
<p>1-3</p> 	<p>Input 100°C.</p>  [000] flashes →    → 
<p>1-4</p> 	<p>00 hour 00 minute</p>  TIME flashes →  → 
<p>1-5</p> 	<p>Repeat:0 (No repeat destination)</p>  REP flashes. →  → 
<p>1-6</p> 	<p>Number of repetition:0 (No repetitions)</p>  REP flashes. →  → 
<p>1-7</p> 	<p>Wait function ON setting (Set time counts down when the indicated temperature is -3°C to the set temperature and within +6°C.)</p>  WAT flashes →  →    → 
<p>1-8</p> 	<p>END setting OFF (To input the next step, set this to OFF; to input the final step, set this to ON)</p>  All program setting items flash →      →  
<p>1-9</p> <p>If a setup of STEP1 is completed</p>	<p>Press the  key longer.</p>









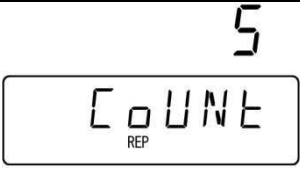
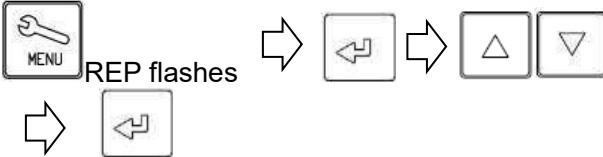

4. Operating procedure

Programming Method

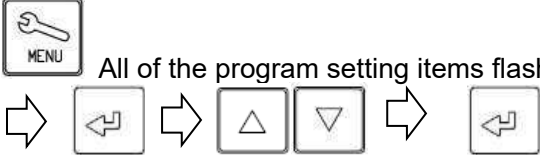
2-1		Input pattern 02, STEP 02 
STEP02 } STEP03 } STEP04 } STEP05 } STEP06	Input parameters from STEP #2 to #6 in accordance with setting conditions with same process of inputting parameters on STEP #1 .	※ Press  key while registering program. Show [REST.P] on Bottom Screen. And show the rest of available steps on Top Screen.
7-1		Input pattern 02, STEP 07  TEMP flashes.
7-2		Input 150°C.       
7-3		Input 00 hour 00 minute.  TIME flashes    
7-4		Input repeat destination (Repeat dstn : 4)  REP flashes       



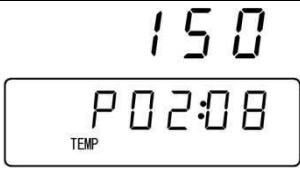

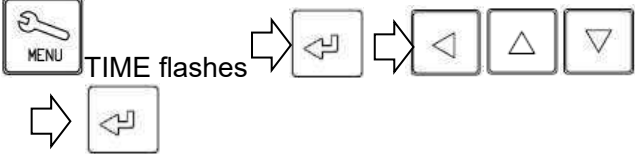



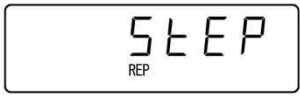

4. Operating procedure

Programming Method

<p>7-5</p> 		<p>Input the number of repetitions(Number of repetitions : 5) ※ Number of repetitions may be set between 1 and 99 or [INF], limitless.</p>  <p>REP flashes</p>
<p>7-6</p> 		<p>Set the wait function to ON. (Set time counts down when the indicated temperature is-3°C to the set temperature and within +6°C.)</p>  <p>WET flashes</p>
<p>7-7</p> 		<p>END setting OFF (To input the next step, set this to OFF; to input the final step, set this to ON)</p>  <p>All of the program setting items flash</p>
<p>8-1</p> 		<p>Input pattern 02. STEP 08</p>  <p>Press the  key longer.</p>  <p>TEMP flashes.</p>
<p>8-2</p> 		<p>Input 150°C.</p> 
<p>8-3</p> 		<p>Input 00 hour 30 minutes. ※ Inputting [INF] for the final step makes its time limitless.</p>  <p>TIME flashes</p>

4. Operating procedure

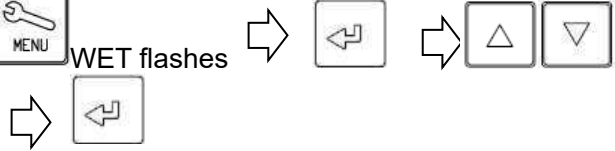
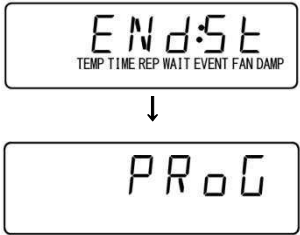







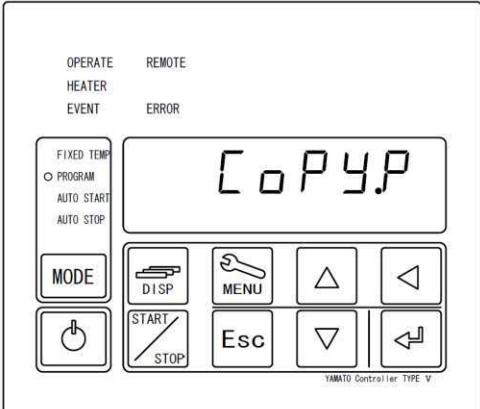

Programming Method

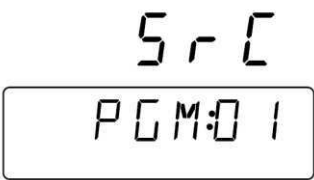
<p>8-4</p>		<p>Input repeat [0] (No repeat dstn)</p>  <p>REP flashes</p> 
<p>8-5</p>		<p>Input a repeat number of [0] (No repetitions)</p>  <p>REP flashes</p> 
<p>8-6</p>		<p>Set the wait function to OFF.</p>  <p>WET flashes</p> 
<p>8-7</p>		<p>Set END to [ON].</p>  <p>All of the program setting items flash</p>  <p>※ Be sure to set the END step ON for the final step of a program pattern. Any operation programs without an END step ON will not be recognized as a complete program.</p>

※ Duplicate and use the programming sheet at the end of this book.





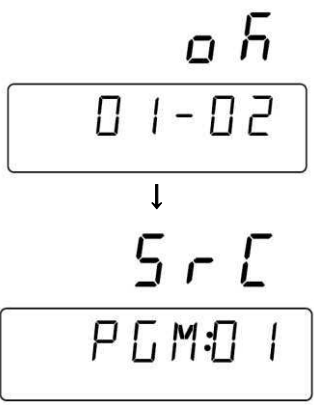

4. Operating procedure

How to copy or delete programs

<p>1-1</p>	 <p>The diagram shows a control panel with a display area at the top. Below the display are several rows of buttons: a row with 'OPERATE', 'REMOTE', 'HEATER', and 'ERROR'; a row with 'EVENT' and 'ERROR'; a row with 'FIXED TEMP', 'PROGRAM', 'AUTO START', and 'AUTO STOP'; a 'MODE' button; a row with 'DISP', 'MENU', and two arrow keys; a row with a power button, 'START/STOP', 'Esc', and two arrow keys. A 'MENU' key with a key icon is highlighted.</p>	<p>※ Copying a program</p> <p>Use the  key to flash [COPYP] on the Bottom screen and press the  key.</p>
<p>1-2</p>	 <p>The screenshot shows the top display with 'Src' and the bottom display with 'PGM:01'.</p>	<p>When [01] of PGM:01 flashes, input the pattern number to copy from with the   keys and then determine using the  key.</p>
<p>1-3</p>	 <p>The screenshot shows the top display with 'dest' and the bottom display with 'PGM:02'.</p>	<p>[DEST] flashes on the Top screen shows while pattern numbers not used and [**] of PGM:** flash on the Bottom screen and input a pattern number [**] of the copy destination with the   keys and determine using the  key.</p>
<p>1-4</p>	 <p>The sequence shows the top display with '01-02', a downward arrow, and then the top display with 'Src' and the bottom display with 'PGM:01'.</p>	<p>The Top screen shows [] and the Bottom screen shows the pattern number of the copy source- copy destination number [01-02] then the screen will move to the program copy screen.</p>

4. Operating procedure

How to copy or delete programs

<p>2-1</p>		<p>※ Deleting a program You cannot delete a program during operation. Carry out deletion while the stand-by screen is displayed.</p> <p>Use the  key to flash [DELP] on the Bottom screen and then press the  key.</p>
<p>2-2</p>		<p>When [01] of PGM:01 flashes, select a pattern number to delete with the   keys or select [AL](all delete) with the  key and then press the  key longer.</p>
<p>2-3</p>		<p>When [DEL] flashes, determine using the  key.</p>
<p>2-4</p>		<p>The Top screen shows [o h] and the Bottom screen shows the pattern number of the copy source- copy destination number [PGM:02] then the screen will move to the program delete screen.</p>

4. Operating procedure

About the wait function

When the wait function is set to [ON], the mode will remain “waiting” without counting down the time until temperature in the furnace (indication) will be within the wait deviation range between -3°C and $+6^{\circ}\text{C}$ to the set temperature. When you set the set time to 0 minute, the unit will operate from the “Start temperature” to the “Set temperature” at full power.

When you have set time longer than the specified performance, the unit will control heating and cooling so that the set temperature will be attained (within the wait width deviation range) at the set time.

Even when the indicated temperature drops while temperature is stable due to opening of the door, the mode will remain “waiting” without counting down the time if the wait width upper or lower limit is exceeded.

When you set the wait function to [OFF], the unit will proceed to the next step at the set time irrespective whether the temperature is within the wait width deviation between the set temperature and the indicated temperature.

When the set time is set to a short time exceeding the heating and cooling capacity, the unit will proceed to the next step before the set temperature is attained and you need to make sure that the wait function is set at [ON] when you are going to operate at the full power.

※ Example of estimated heating/cooling

ing at indicated setting of wait [All ON] and [ALL OFF] in the program in the table below.

Step	1	2	3	4	5	6	7	8	9	10
Set temp($^{\circ}\text{C}$)	1000	1000	500	500	1000	1000	500	500	750	750
Set time	0 min	30min	0 min	30min	0 min	5 min	0 min	5 min	2hr	30min
	Heating and cooling time of steps (1), (3), (5) and (7) are at the full power setting.									
	Heating time of the step (9) has been set longer than the specification.									

【Example of estimated process at “Full ON” setting for the wait function】

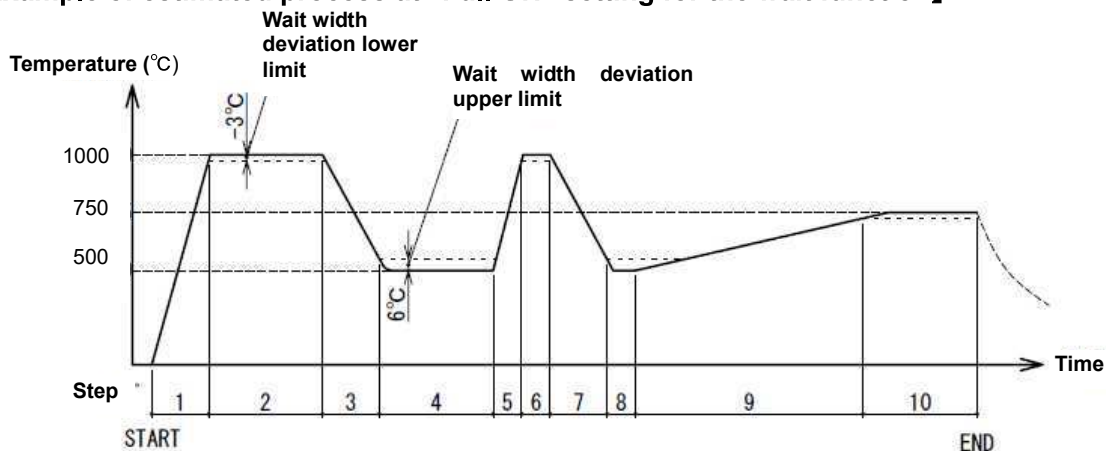

【Example of estimated process at “Full OFF” setting for the wait function】

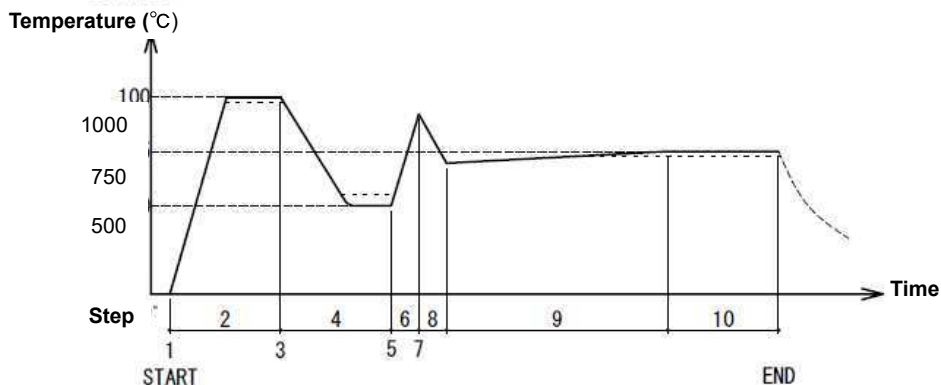

4. Operating procedure

Setting key lock mode

※ Set the key lock mode.

1 Turn the controller power off

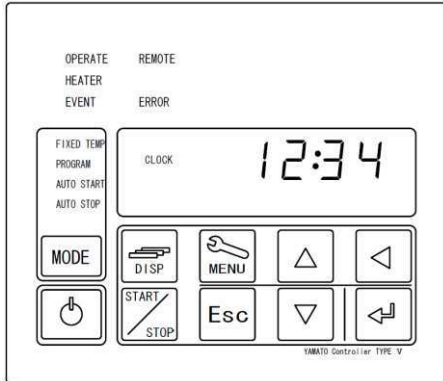



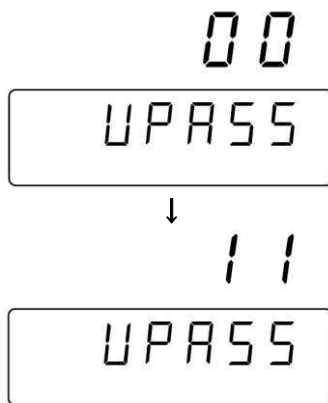

Turn the ELB on the left side of the main unit [ON(|)]. The Bottom screen will show the current time.

While the unit is being operated, press the  key longer to turn the controller power off.





2 Enter password



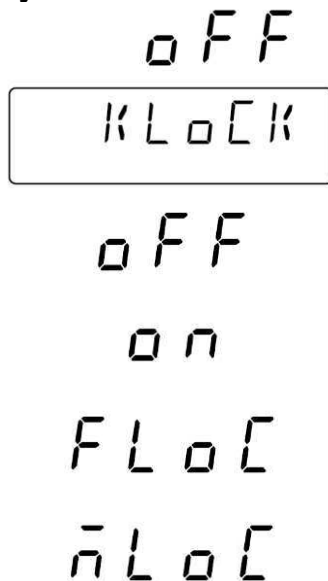

- ① Press and hold  key.
Show [UPASS] on Bottom Screen and [00] flashing on Top Screen.
- ② Press   and  keys to enter password "11" on Top Screen and press  key (The password is fixed to "11").

3 Set key lock



- ① The Bottom screen shows [KLOCK] while the Top screen shows [OFF]. [OFF] is the factory setting.
- ② Use the     keys to select a type of key lock and then determine using the  key.

OFF : Key lock function disabled (Factory setting)

ON : Any keys other than the  and the  keys are disabled.

FLOC : Only the  key is disabled.

mLOC : Only the  key is disabled.

- ③ Pressing the  key longer will return to the time display screen.

4. Operating procedure

Calibration offset

Calibration Offset Function offset the difference between read temperature by this Controller and actual measured temperature of Furnace. This Function enable parallel compensation in minus or plus direction over the whole Controller Temperature Setting Range of this Equipment.











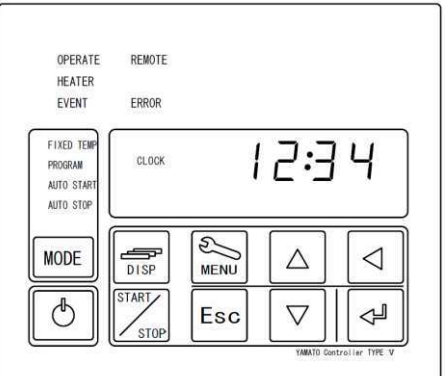

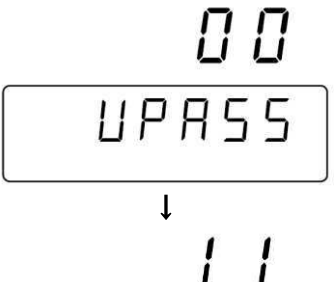



Example

When the measured Furnace temperature is lower than read temperature by 2°C:

The read temperature can be calibrated by inputting "Calibration Offset value -2.0" for 2°C compensation against actual Furnace temperature.











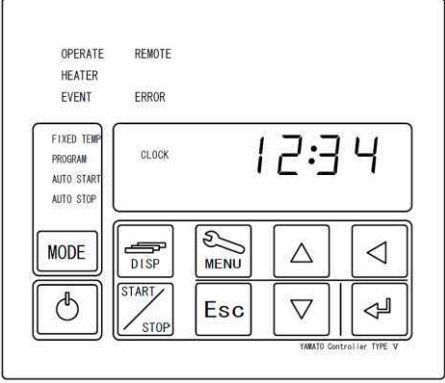

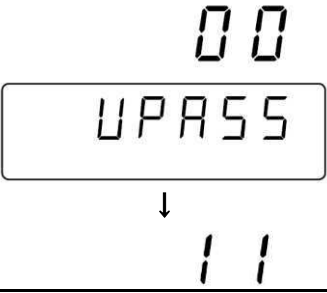

If read temperature is 200°C for example, its temperature will shift to 198°C after offset calibration.

※ This -2°C compensation is applied over the whole controller Temperature Setting Range (FP : 0°C~1200°C). Note that offset value might be changed depending on sample setting arrangement and/or Target Temperature.

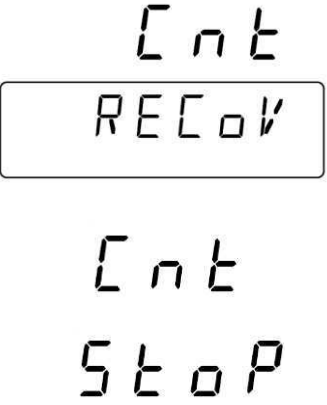
<p>1</p>	<p>Turning the controller power off</p> 	<p>Turn the ELB on the right side of the main unit [ON ()]. The Bottom screen will show the current time.</p> <p>While the unit is being operated, press the  key longer to turn the controller power off.</p>
<p>2</p>	<p>Enter password.</p> 	<p>① Press and hold  key. Show [UPASS] on Bottom Screen and [00] flashing on Top Screen.</p> <p>② Press ,  and  keys to enter password "11" on Top Screen and press  key (The password is fixed to "11").</p>
<p>3</p>	<p>Set Calibration Offset value.</p> 	<p>① Press  key to display [CAL:05] on Bottom Screen then press  key.</p> <p>② Input offset value by ,  and  keys and then press  key. You can enter an offset amount up to ±15.0°C</p> <p>Example Read temperature : 200°C and actual measured temperature : 198°C ⇒ Offset input value: -2.0°C</p> <p>※ Although you can input values up to the first decimal place, the temperature indications and measured temperatures will be rounded before indication.</p> <p>③ Pressing the  key longer will return to the time display screen.</p>

4. Operating procedure

Setting the recovery mode

<p>※ Describe the recovering operation at power failure.</p>	
<p>1 Turning the controller power off</p> 	<p>Turn the ELB on the right side of the main unit [ON()]. The Bottom screen will show the current time. While the unit is being operated, press the  key longer to turn the controller power off.</p>
<p>2 Enter password.</p> 	<ol style="list-style-type: none"> ① Press and hold  key. Show [UPASS] on Bottom Screen and [00] flashing on Top Screen. ② Press   and  keys to enter password "11" on Top Screen and press  key (The password is fixed to "11").
<p>3 Setting recovery from a power outage</p> 	<ol style="list-style-type: none"> ① Press  key to display [RECOV] on Bottom Screen and then press  key. ② Press   key to select recovery type at power failure and press  key. <p>CNT : The operation will resume right at power failure after power recovery. (set at factory)</p> <p>STOP : The operation will terminate as Idle State after power recovery.</p> <ol style="list-style-type: none"> ③ Pressing the  key longer will return to the time display screen.

4. Operating procedure

Resetting integrated CO2 volume and CO2 emission factor

※ Explain how to set conversion factor for CO2 emission and how to reset the integrated CO2 volume on Top Screen.

1 Turning the controller power off

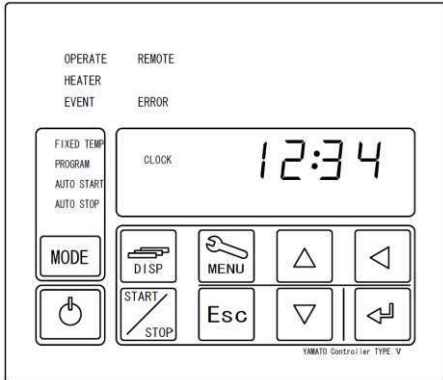

Turn the ELB on the left side of the main unit [ON(|)]. The Bottom screen will show the current time.

While the unit is being operated, press the key longer to turn the controller power off.

2 Enter password.

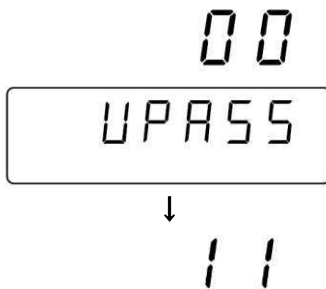

- ① Press and hold key.
Show [UPASS] on Bottom Screen and [00] flashing on Top Screen.
- ② Press and keys to enter password "11" on Top Screen and press key (The password is fixed to "11").

3 Reset monitor display.

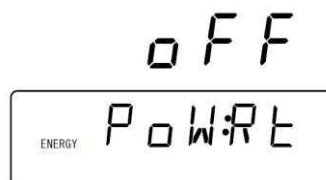
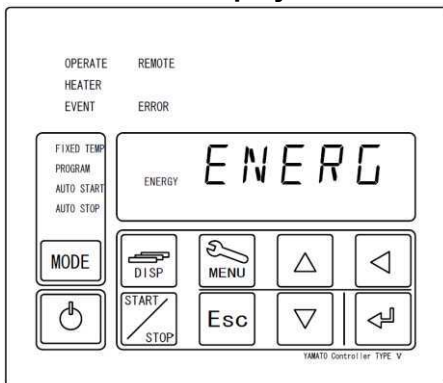

- ① Pressing the key will make the monitor function indication ENERGY and [ENERG] flash on the Bottom screen.
- ② Pressing the key will show items to reset integrated [POWRT] power consumption.
- ③ Press key to select monitoring item on Bottom Screen and then press key.

POWRT : Integrated power consumption

Pressing the key will result in:

OFF (lit) → RUN (flash)

Press key to reset Integrated Power Consumption.

Press key to return to [PoW:Rt].

4. Operating procedure

Resetting integrated CO2 volume and CO2 emission factor

3

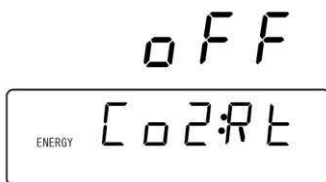
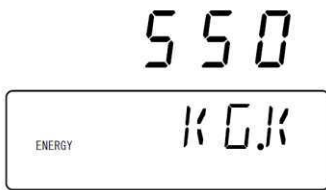

KG.K : (CO2) discharge coefficient

Quoted from the substitutive values, factory setting of **550** (0.000550t-CO2/kWh) , the Environmental Ministry Press Release on 6 November 20013.

Confirm the discharge coefficient of different utility companies with each company.

Pressing the  key will result in:

550 (lit) → **0550** (flash)

Press the    keys to change a discharge coefficient.

 key is used to determine

 key is used to return

CO2:RT : Integrated CO2 Emission

Press  key, and then change from OFF (illuminate) to →RUN (flash) on Top Screen.

 key is used to reset Integrated CO2 Emission.

 key is used to return

④ Pressing the  key longer will return to the time display screen.

4. Operating procedure

Backup data saving / reading out / resetting

※ Back up, read out and reset controller for various setting information.

1 Turning the controller power off

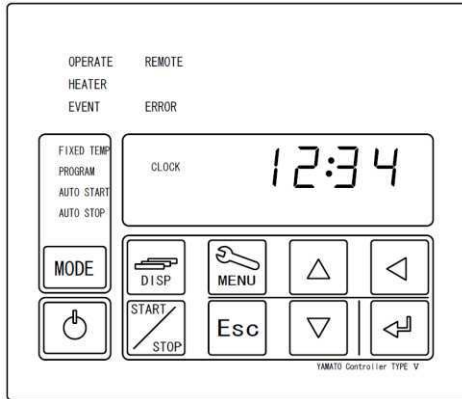

Turn the ELB on the left side of the main unit [ON(|)]. The Bottom screen will show the current time.



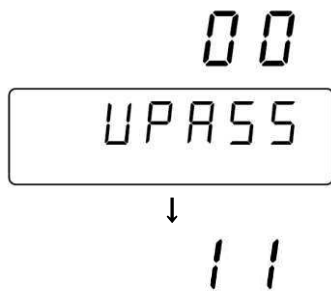

While the unit is being operated, press the  key longer to turn the controller power off.

2 Enter password.



① Press and hold  key.

Show [UPASS] on Bottom Screen and [00] flashing on Top Screen.

② Press ,  and  keys to enter password "11" on Top Screen and press  key (The password is fixed to "11").

3 Save and read out and/or reset setting information.



① Press  key few times and show following items on Bottom Screen, respectively:

U BKS : Back various setting information up.

 key「RUN」(flash)→ key「OFF」(illuminate)

U BKR : Read backup setting information out.

 key「RUN」(flash)→ key「OFF」(illuminate)

INI.U : Initialize various setting information.

 key「RUN」(flash)→ key「OFF」(illuminate)

※ Various setting information will be included registered programs, temperature offset value and other data such as key lock mode, calibration offset, recovery mode and so forth.

② Pressing the  key longer will return to the time display screen.

4. Operating procedure

Monitoring data

※Check Integrated Power Consumption, integrated Operating hours and so forth by this “Monitor Item Display” function of this Equipment.

Can not modify any setting information shown on Top Screen.

1 View integrated value on Top Screen

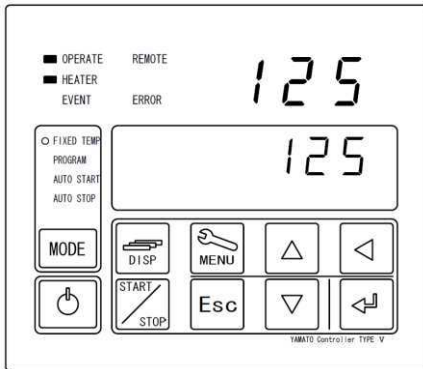

0.0



123

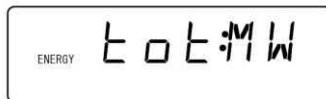

456



456



789

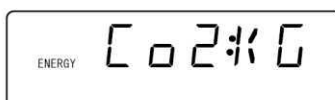

※Monitor Items can be checked at Controller POWER key ON or during operation state.

Press and Hold  key.

Monitor Items display screen activate and current Power Consumption appear on Top Screen.

Use the  key shows the integrated power consumption (MW) (kW), CO2 discharge amount (t) (kg) heater operation amount (%), integrated live time (Unit: 10000 hours) (Unit: 1000 hours), integrated operation time (Unit: 10000 hours) (Unit: 1000 hours).

Monitor Items display screen is ended, and Idle Screen or Standby Screen is displayed finally.

KW Current Power Consumption is calculated from instantaneous power to power at one hour. Power consumption may be indicated as [0.0] and [3.6] alternately while temperature is stable. Power consumption is indicated as [0.0] during standby.

TOT:MW Integrated power consumption (MWh). This is indicated in a three-digit integer number.

TOT:KW Integrated power consumption (kWh). This is indicated in a three-digit integer number.

【 Sample indication 】 Integrated power consumption:123,456kWh

CO2:_T CO2 discharge amount (t). This is indicated in a three-digit integer number.

CO2 discharge amount is calculated by multiplying the power consumption by a discharge coefficient. Confirm the discharge coefficient of different utility companies with each company.

The initial value input is quoted from the substitutive values, factory setting of 0.550(k-CO2/kWh), the Environmental Ministry Press Release on 6 November 20013. For updates of the coefficients, see the section, Setting and resetting the monitor indication, item [3].

CO2:KG CO2 discharge amount (kg). This is indicated in a three-digit integer number.

【 Sample indication 】 CO2 discharge amount:456,789kg

<p style="text-align: center;">45.6</p> <div style="border: 1px solid black; padding: 5px; margin: 5px 0;">ENERGY PID:MV</div> <p style="text-align: center;">5</p> <div style="border: 1px solid black; padding: 5px; margin: 5px 0;">ENERGY POW:TM</div> <p style="text-align: center;">67</p> <div style="border: 1px solid black; padding: 5px; margin: 5px 0;">ENERGY POW:TM</div> <p style="text-align: center;">1</p> <div style="border: 1px solid black; padding: 5px; margin: 5px 0;">ENERGY RUN:TM</div> <p style="text-align: center;">23</p> <div style="border: 1px solid black; padding: 5px; margin: 5px 0;">ENERGY RUN:TM</div>	<p>PID:MV Heater Operation Output Heater Operation Output is the parameter to control output power ratio in percent of heater rated capacity. Heater output will be controlled by PID operation value between 100 to 0% till reaching to Target Temperature.</p> <p>【Sample indication】 Present heater operation amount: 45.6%</p> <p>POW:TM Integrated live time (hours). Only the ten thousand digit will be indicated.</p> <p>Integrated live time shall be the accumulated time elapsed from turning the ELB ON() to OFF OFF(○).</p> <p>POW:TM Integrated live time (hours). Up to the thousand place is displayed.</p> <p>【Sample indication】 Integrated Power ON Hours ; 50,067 hours Adding capability will up to 65,535 hours.</p> <p>PUN:TM Integrated operation time (hours). Only the ten thousand digit will be indicated.</p> <p>Integrated Operation Run Hours mean to add operation hours from start to end.</p> <p>PUN:TM Integrated operation time (hours). Up to the thousand place is displayed.</p> <p>【Sample indication】 Integrated live time: 10,023 hours Up to 65535 hours can be cumulated.</p> <p>Use the  key to the standby/operating screen.</p>
--	--

4. Operating procedure

Independent Overheat Prevention Device

This Equipment has redundant safety devices-1) Automatic Overheat Prevention (automatic reset) function on the Controller, and -2) Independent Overheat Prevention Device (IOPD) with independent power, circuit and sensor away from the Controller.

Main Relay of this Controller will be shut heater output power off when one of safety devices is activated at Furnace internal temperature beyond its setting temperature.

Those functions will avail at Earth Leakage Breaker(ELB) ON(|).

Set temperature on Independent Overheat Prevention Device(IOPD)

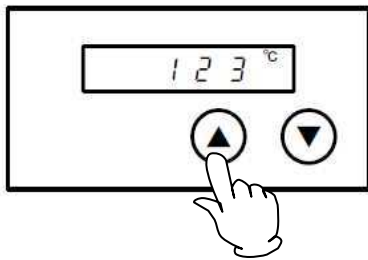

※Set temperature with ▼▲ keys on its panel.



May stop its operation by activating Independent Overheat Prevention Device(IOPD) when the difference between set temperature on IOPD and Target Temperature will be too close each other. Must set IOPD temperature at least 100°C higher than Target Temperature.

The temperature is set at 1250°C at the factory shipping.

Note that the objective of this IOPD will not protect for samples but from overheating this Equipment.

Note that this can prevent accidents as a result of using explosive or combustible substances.

Factory settings and setting temperature ranges are as shown below:

Model	Set temperature at shipment	Setting temperature range
FP103/303/313/413	1250°C	0°C~1300°C

Control Furnace stable at required temperature first, and let IOPD setting temperature down by 1°C and then find out IOPD activating temperature, if IOPD will get to be activated at required temperature.

Must wait for 5(five) seconds for the next 1°C down of IOPD setting temperature, because its function will be operated to need some times.

Display ER07 on Top Screen on Control Panel, if this IOPD is activated.

When you have set an operation temperature you want for IOPD , recording of the set temperature takes several seconds and you need to wait for about five seconds before turning the ELB off.

4. Operating procedure

Temperature increase & decrease (reference data)



The graph below shows temperature increase & decrease data for different models. Use the data only as a reference since it will change depending on the amount of samples or the environmental temperature.

Use these figures as a reference for temperature increase during programming.

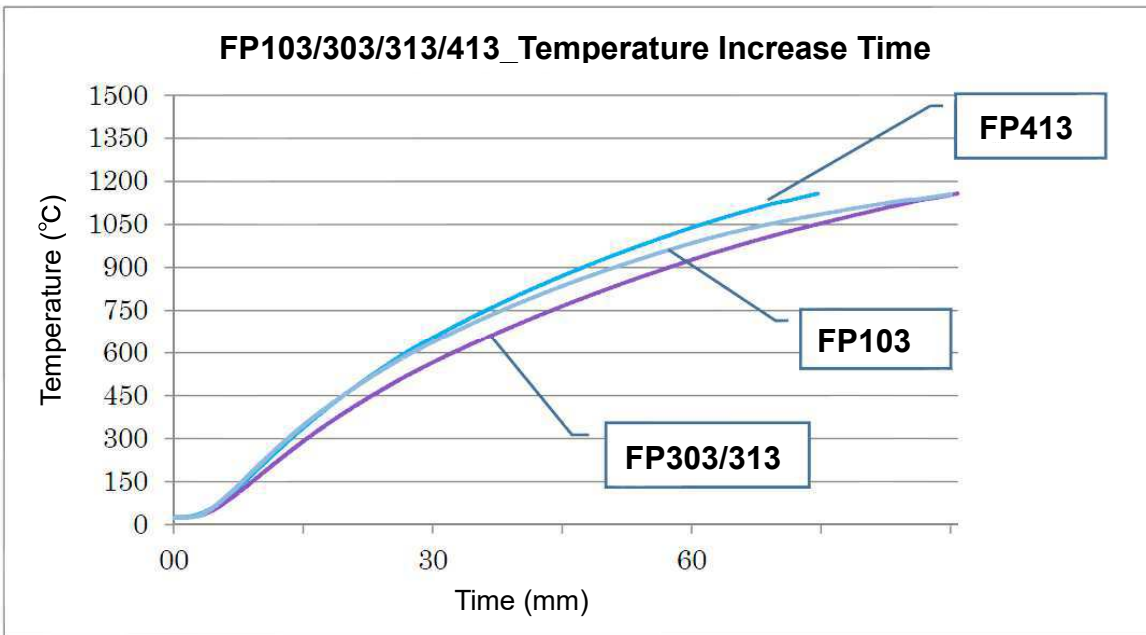

Use these figures as a reference for temperature decrease during programming.

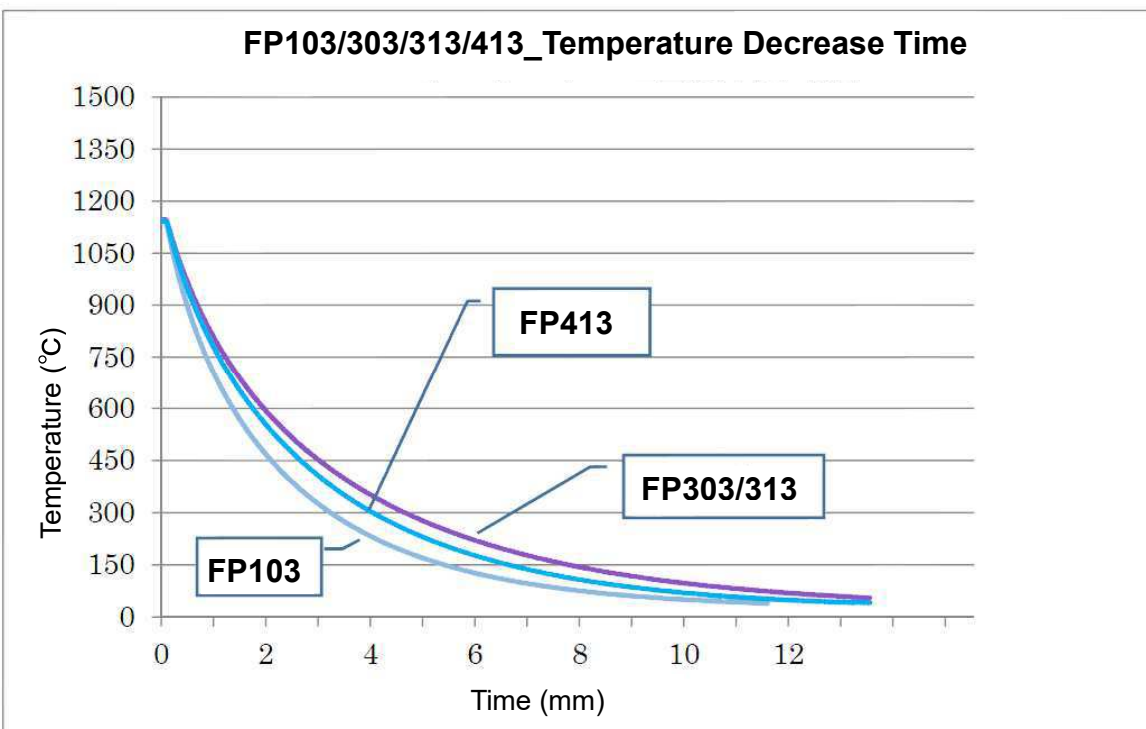

5. Handling precautions

Warning and caution

1. Never use any explosive or flammable substances.

 Never process any explosive, flammable samples and also samples contained with those substances. It will cause fire/explosion. (See Chapter 13. List of dangerous materials on page 69.)

2. Never use toxic substances with this product.

 Never use toxic specimens or specimens that will generate toxic gas with this unit. An accident may result.

3. Turn the ELB off when an abnormality occurs.

 Turn immediately off Earth Leakage Breaker (ELB) of this Equipment and disconnect Power Cord/Power Cable from receptacle or switch board of facilities, if smoke or strange smell is generated from it by any chance.
Contact with local dealer or Yamato sales office and/or Yamato Customer service Center and ask them to inspect it. If nothing is done to it, fire or electrical shock may result.
Never repair it by customer themselves to avoid any dangers.

4. Do not climb on the Equipment.

 Do not climb on this Equipment. May cause personal injury and/or its failure by tipping it over and being damaged.

5. Do not place any object on the product.

 Do not place any object other than the optional exhaust unit on the product. It might fall and cause a malfunction or a personal injury. Do not place paper or other easily combustible objects around the unit.

6. Do not stack this product on another one.

 Do not stack this product on another one. A fire or a malfunction may result.

7. Turn immediately off the Breaker of the Equipment at thundering.

 Turn immediately off the Breaker of the controller, when thundering and lightning start. If do not so, it may cause fire or electric shock by the thunderbolt.

 This product resumes operation automatically if power is shut off during operation due to power outage and then power is recovered.
See "P.42 Setting the power outage recover mode" for details.

8. Smoke may generate when you operate the unit for the first time.

 When you operate the unit for the first time, the carbonizing organic components contained in the furnace binder may burn and generate odor, which, however, does not indicate a malfunction of the unit. Please make sure the room is well ventilated. Odor will not generate as you continue to use the unit for some time. The furnace body may darken or gray after operation, this is the result of carbonizing organic components contained in the furnace binder, and has no effect on performance.

9. Take extreme care when using a resin container.

 Be sure to check the withstand temperature before using a resin container. Using such a container under a temperature beyond its withstand temperature will melt resin and a fire or an explosion may result.

5. Precautions on Handling

Warning and caution

10. Do not process any corrosive samples

-  Do not process any samples containing corrosive chemicals even though Furnace is made of stainless steel which this steel may be corroded by strong chemical acid, etc.

11. The furnace body may be cracked.

-  Operating at a high temperature or opening and closing the door at a high temperature might cause a crack in the furnace body, which will not have any adverse effects on the operation or the performance.
- Note that chemical reaction with the substances listed in the table below may shorten the use life of the furnace body.

Substance	Reaction temperature	Substance	Reaction temperature
Hydrofluoric HF	Whole temperature range	Methane CH ₄ (C _m H _n)	600~1000°C
Alkaline (Na ₂ O, CaO, K ₂ O, etc.)	600~1300°C	Chlorine Cl ₂	800°C or above
Hydrogen H ₂	1000°C or above	Nitrogen N ₂	1000°C or above

12. Take extreme care when opening the door during operation at a higher temperature.

-  When you attempt to open the door during operation at a higher temperature, never touch the door since the internal furnace or the inside of the door are hot.
Note that if a fire alarm is installed around the unit, it may go off erroneously.

13. Opening the door at a high temperature will affect the device adversely.

-  Minimize opening the door when the furnace body temperature is 500°C or above. Opening the door at a high temperature will adversely affect the sensor, the furnace body and the heater lives. Radiation heat might cause damages to the operation panel and the controller.
If you cannot avoid opening or closing the door, immediately close the door after completing the necessary work.

14. Do not leave the door open after operation.

-  Do not leave the unit with the door open for the purpose of cooling the specimen quickly after operation. Heat from inside the furnace may cause deformation of the control panel or damages to the control devices.

15. Take care for burning.

-  After operation of the unit at a high temperature, the furnace body, the inside the door and the specimen will remain hot for some time after completion of operation.
Take care for burning if you touch these parts when putting or removing the specimen. Be sure to put heat-resistant gloves on and handle the specimen with sufficient.

16. Use the unit at the correct temperature.

-  The temperature control range is between 100°C and 1150°C (FP103/302/312/412).
Never attempt to use the unit at a temperature outside the temperature control range. Using outside the operating temperature range may lead to a malfunction of the device or an accident.

5. Precautions on Handling

Warning and caution



17. Take care for the temperature in the furnace after operation is completed.

-  If the cooling fan of the unit stops at a high temperature, the external package may overheat or the fuse may be disconnected. Even if operation has been completed, do not turn the ELB OFF or remove the power plug while the temperature in the furnace is 600°C or higher. (Excluding an emergency)

18. Place specimens on the furnace floor plate.

-  When placing specimens in the furnace, first put the floor plate on the bottom in the furnace on which specimens will be placed. Placing specimens directly may damage the furnace body or cause a fire.



19. Take care for handling of specimens.

-  Placing too many specimens may prevent proper temperature control. Avoid operating the unit under overload in order to assure the proper temperature precision.
-  Blower wind of the cooling fan is discharged at the front plate. Take care when processing powder or smaller specimens so that they will not be dispersed.
-  Take care not to touch the furnace inlet material of the furnace body when placing or removing specimens in and out of the furnace so that the furnace inlet material will not be damaged. Damages of the furnace inlet material will adversely affect temperature control.

20. Note that the sample temperature and the measured temperature are not always the same.

-  Be aware of temperature sensor which it is installed on Furnace inside upper portion and control Furnace temperature. Therefore, if the amount of specimen is large or the equipment is in the middle of heating, sensor detected temperature may not agree with temperature of the samples. In particular, actual Furnace temperature will differ greatly from Read Temperature displayed on Controller, right after opening or closing of this Equipment Door. When a gap occurs between the temperature in the bath and the measured temperature requiring adjustment, compensate temperature by referring to “P.41 Setting a calibration offset” .

21. Do not put a foreign object inside.

-  Do not insert a metal or an easily-combustible foreign object into the openings of the furnace body (radiation ports or exhaust port). Otherwise, a fire, an electrical shock or burning may result.
-  If any foreign objects have entered inside, immediately turn the ELB off and contact your dealer, one of our sales offices or the general customer service center for inspection. Otherwise, a fire or an electrical shock may result.

22. To form a protective film of the heater.

-  The heater of the unit will form a protective film on its surface at a high temperature. If you ordinarily use the unit at a relative lower temperature of 700°C or less, operate at 1050°C for 10 hours at least once so that a protective film will be formed.

23. About corrosion of the heater

-  The heater of this unit will corrode with chloride, fluorine or other halogens as well as sodium, potassium or other salts and care must be taken so that such substances will not come into contact with the heater.

5. Precautions on Handling

Warning and caution

24. About corrosion of the sensor



Do not use the sensor of the unit with alkaline metals, metal vapors, various oxidized metals, carbon monoxide, carbon, phosphorous, selenium, arsenic or other reducing elements or a reducing atmosphere to avoid corrosion of the sensor.

25. About the standalone overheat preventive unit



When the difference between the set temperature for the standalone overheat preventive unit and that of the controller is small, the overheat preventive unit may activate, indicate [ER07] and operation may stop. Set the temperature for the overheat preventive unit at a temperature higher than that of the controller by at least 100°C. (This unit is a high temperature furnace and may often present overshoot at a lower temperature setting. Use this overheat preventive unit for the purpose of protecting the unit.) This is set at 1250°C at the factory shipping.

26. About the installation of the exhaust unit



When you use the optional exhaust unit for this unit, connect the ground wire included with the exhaust unit to the chassis of the main body.

27. Precautions on using N2 gas



In the N2 gas atmosphere, nitriding on the heater surface proceeds due to a high temperature, which prevents formation of a protective film, and the upper limit of operation temperature will be lower unlike in the air atmosphere. (Due to the upper use limit in the N2 gas atmosphere.) Keep the temperature in the range of 100~900°C when operating the unit in the N2 gas atmosphere.

28. Take care for the fan at the back of the unit.



Take care not to pinch your finger in the fan at the back of the unit.

29. Never fail to perform periodic inspection.



The ELB and the standalone overheat preventive unit are important devices for safety. Never fail to conduct period inspection for these devices. See "P.54 Maintenance method" for how to inspect the unit.

30. Precautions when wiping dirt of the unit



- Never use thinner or alcohol to wipe dirt of the unit.
- The paint may be peeled off or the plastic part may be discolored or deform.
- Be sure to turn the ELB on the left side of the unit before taking care of the unit. See "P.54 Maintenance method".

31. Be sure to read the operating instructions.



Be sure to read the operating instructions before using the unit.

6. Maintenance method

Daily inspection/maintenance



Warning

- Be sure to turn off Earth Leakage Breaker(ELB) of this Equipment before daily inspection and maintenance
- Inspect and maintenance this Equipment at ambient temperature on its Furnace.
- **Never disassemble this Equipment.**



Caution

- Wipe dirt off with wrung tightly soft cloth.
Never clean this Equipment with benzene, thinner or scouring powder, or rub with a scrubbing brush. May cause deformation, degradation and/or discoloration.
- Too much dust on the cooling fan will degrade cooling effect. Clean the fan with a vacuum cleaner.
- Where the furnace door seal mounted on the furnace body is damaged, immediate replacement is recommended.
Continuing to operate unit in such condition may result in degraded performance, fire, or other accidents.
Contact original dealer of purchase for requesting charged replacement service.

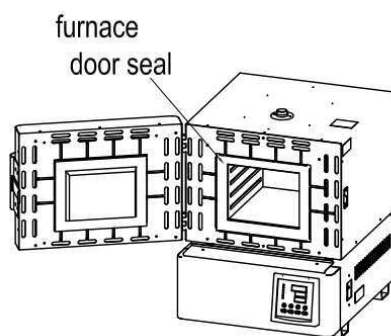



Inspect monthly.

- **Inspect the ON and OFF functions of Earth Leakage Breaker (ELB).**
 - Prepare this Equipment for the inspection and connect Power Cord/Cable to receptacle or Switch Board of facilities.
 - Check ELB "OFF", then turn ELB "ON(|)".
 - Press test button on ELB with ball-point pen etc. If ELB is shut down, ELB will be functional.
- **Check operation of Independent Overheat Prevention Device (IOPD).**
 - Be operating this Equipment at appropriate Target Temperature on Fixed Temperature Operation Mode.
 - Set this IOPD working temperature down to approximately 10°C lower than Read Temperature.
 - Activate this IOPD and will be shut power off heater circuit in few seconds, and display "Er07" on Top Screen, display warning sign "Overheat" on Bottom Screen, illuminate ERROR Lamp on Control Panel, and buzz on the same time.
 - * Must check ELB and IOPD mentioned above prior to operate this Equipment for continuous long hours or unmanned operation during night time before starting operation.

- ◆ Contact immediately with local dealer, Yamato sales office, or Yamato Customer Service Center for any questions.

7. Long storage and scrap

When not using the Equipment for a long time / when scrapping

 Warning	 Caution
Do not operate this Equipment for the time being. ● Turn Earth Leakage Breaker(ELB) off and disconnect Power Cord/Cable from receptacle /switch board of facilities.	Scrap this Equipment. ● Do not leave this Equipment alone where children may play and get at it. ● Before discarding the equipment, be sure to remove the hinge and the door lock assembly so that you cannot close the door hermetically.

Matters to consider when scrapping the Equipment

Pay attention always to the preservation of the global environment.

We, as Yamato Scientific Co., Ltd. highly recommend taking this Equipment apart as far as possible for separation or recycling to contribute to the preservation of the global environment according to the specified garbage collection method stipulated by each local government..

List major components and their materials for this Equipment as follows:

Names of major parts	Material
Major components of the Equipment	
Main unit	Steel plate, melamine, epoxy composite resin paint, stainless steel
Furnace body, door furnace body	Alumina fiber
Name plate	Polyethylene (PET) resin film
Major components of electrical parts	
Switch and Relay	Resin, copper, and other composite parts
Operation Panel	
Printed Circuit Boards	Glass fiber and other composite parts
Heater	Iron chrome wire
Power Cord	Synthesized rubber sheath, copper, nickel or other composite parts
Wires	Glass fiber, fire-retardant vinyl, copper, nickel or other composite parts
Stickers	Resin materials
Sensor (K thermo-couple)	Platinum element

8. When a trouble occurs

Message error table

Show the error codes on Table 8.1 below.

Buzz and stop its operation at occurring errors on this Equipment.

Pressing any key (except for the  key) will stop the buzzer sound. When three minutes have passed as it is, the buzzer starts to sound again.

The Top screen shows an error code and the Bottom screen shows the error name. Note the error code, immediately turn power off and stop operating the unit.

Table 8.1 Table of Error Code

Error Display	Error Code Name	Causes and their solutions
ER01 SENS	Sensor Failure	<ul style="list-style-type: none"> ● Fail in temperature sensor. ● Open circuit on temperature sensor line. ● Detect temperature out of its designed range. Contact with local dealer or Yamato Customer Service Center.
ER02 TRIAC	TRIAC short circuit error	<ul style="list-style-type: none"> ● Short on TRIAC circuit. ● Fail on Current Transformation (CT) sensor. Contact with local dealer or Yamato Customer Service Center.
ER03 HEAT	Heater Line Disconnection	<ul style="list-style-type: none"> ● Heater Line Disconnection ● Fail on Current Transformation (CT) sensor. ● The source voltage has dropped. Contact the general customer service center.
ER07 OHEAT	Independent Overheat Prevention Device(IOPD) activated	<ul style="list-style-type: none"> ● Activate Independent Overheat Prevention Device (IOPD). Turn ELB on again and check both Furnace temperature and setting Temperature of IOPD. Contact with local dealer or Yamato Customer Service Center, if this Equipment is not energized at ELB on.
ER10 RELAY	Main Relay Contact melted	Check at turning ELB on again: <ul style="list-style-type: none"> ● Melt down the contact point of Main Relay. ● Fail on Current Transformation (CT) sensor(s). Contact with local dealer or Yamato Customer Service Center.
ER14 RAM	RAM Failure Reduced capacity or end of use life of the backup battery	Check at turning ELB on again: <ul style="list-style-type: none"> ● RAM Failure : Reset power once. ● Reduced capacity or end of use life of the backup battery : Contact with local dealer or Yamato Customer Service Center, if this error cannot be reset by ELB on. Must be replaced backup battery.

8. When a trouble occurs

Message error table

Error Display	Error Code Name	Causes and their solutions
ER15 EPROM	EEPROM Failure	Check at turning ELB on again: <ul style="list-style-type: none">● Change its data code on EEPROM. Contact with local dealer or Yamato Customer Service Center, if this error cannot be reset by ELB on. Must be replaced backup battery.

8. When a trouble occurs

Troubleshooting

Show troubleshooting guide on Table 8.2.

Refer to “Cause and their solutions” of Table 8.1 – Error Code on this Chapter “Message Error Table” at

Table 8.2 - Troubleshooting Guide

Phenomena	Causes	Solutions
Do not display current time on Bottom Screen at Earth Leakage Breaker (ELB) ON.	<ul style="list-style-type: none"> ▪ Do not supply power. ▪ Fail ELB. ▪ Fail Controller. 	<ul style="list-style-type: none"> ▪ Check connection to power supply and apply power. ▪ Replace ELB. ▪ Replace Controller.
Do not display anything on both Top and Bottom Screen at Controller Power key pressed and held.	<ul style="list-style-type: none"> ▪ Fail supplied power. (Required Voltage $\pm 10\%$) ▪ Fail Controller. 	<ul style="list-style-type: none"> ▪ Connect to adequate power supply. ▪ Replace Controller.
Do not rise Furnace temperature.	<ul style="list-style-type: none"> ▪ Activate IOPD and /or Self-diagnosis Function built-in on Controller, and shut heater circuit down (Error code displayed). 	<ul style="list-style-type: none"> ▪ Refer to “Cause and their solutions” of Table 8.1 – Error Code on page 56.
Display temperature unstable.	<ul style="list-style-type: none"> ▪ Fluctuate ambient temperature heavily. ▪ Fail supplied power. (Required Voltage $\pm 10\%$) ▪ Fail Controller. ▪ Fail Temperature Sensor ▪ Be affected by samples. 	<ul style="list-style-type: none"> ▪ Review its location. ▪ Connect to adequate power supply. ▪ Replace Controller. ▪ Replace Temperature Sensor. ▪ See “P.52 19. Take care for processing of powder and small samples”.

Contact with local dealer or Yamato Customer Service Center phenomena other than Table 8.2 above.

9. After sales service and warranty

Request to repair parts

Request to repair parts

When any abnormality occurs immediately stop operation, turn the controller power and the ELB off and contact your dealer, one of our sales offices or the customer service center.

Require the following information for repair.

- Model name of Yamato products
- Serial Number
- Date (year/month/date) of purchase
- Description of trouble in detail as possible

See Warranty Card or caution rating nameplate on this Equipment.
(See Chapter 3. Names and functions of each part "on page 10 for details.

Be sure to present the warranty card to Yamato service representative.

Keep Warranty Card with care.(attached separately)

- Keep Warranty Card with care.
Warranty Card would be given by local dealer or one of Yamato sales offices.
Date of purchase of this Equipment and other information should be filled in Warranty Card.
Please send Warranty Card to Yamato Customer Service Center(Yamato CSC) by facsimile described Fax number in the left top corner of it.
Then, keep its Card with good care.
- Repair this Equipment for free of charge according to the contents on Warranty Card.
Warranty period is 1(one) year from date of purchase.
- Consult with local dealer, one of Yamato sales office or Yamato CSC for any repair after warranty ended.
Charged repair service of this Equipment will be available on customer's request when it can be maintained functional by its repair.

Guarantee for maximum storage period of repair parts.

Guarantee that maximum storage period of repair parts will be 7(seven) years after end of their production, Muffle Furnace FP103/302/312/412.

Repair parts will be defined the parts to maintain this Equipment performance.

10. Specifications

Specifications

Product Name		Muffle Furnace			
Model Name		FP103	FP303	FP313	FP413
Product Code		214145	214146	214147	214148
System		Natural convection			
Operating environment temperature range		5°C~35°C			
Power supply		Single phase AC115V		Single phase AC220V	
		Common to 50/60Hz, operating voltage range : ±10%			
Performance ※1	Temperature Control Range	100~1,150°C			
	Temperature control precision※2	±1.0°C (at1150°C)			
	Temperature fluctuation ※2	±1.0°C (at1150°C)			
	Temperature distribution precision※2	±4.0°C (at1150°C)			
	Temperature slope ※2	14.0°C (at1150°C)			
	Temperature rise time	Approx. 90 min.			Approx. 80 min.
Composition	Exterior	Chrome-free electro-galvanized steel plate Chemical proof baking finish			
	Furnace body	Alumina fiber			
	Sensor	R thermo-couple			
	Heater	Iron chrome wire (Pyromax)			
		1.1kw	2.4kw		3.25kw
	Exhaust port	I.D.20mm(Upper part)			
Cooling fan	19/16W (50/60Hz)				
Controller	Type	V-shaped			
	Temperature Control Method	PID Z control			
	Temperature setting method	Digital setting with ▲/▼ keys.			
	Temperature Display Method	Setting temp. display : Orange 5-digit LED Digital Display (Resolution : 1°C) Temp. display : Green 4-digit LED Digital Display (Resolution : 1°C)			
	Other displays	LED indicates temperature patterns for heating/stable/cooling			
	Timer/timer resolution	Time: 1 minute and 99 hours 59 minutes/1min 24 hour setting			
	Operating function	Fixed temperature operation, quick auto stop, auto start, , auto stop, Program operation: Maximum 99 steps, up to 99 patterns, the repeat operation function			
	Additional function	Power on and Operation Time Integrating Function(up to 65,535 hours); calendar timer (24hours) Calibration Offset; Power Consumption, Total CO2 Emission, and Heater operating Output; Power Recovery Mode; Save and Access of Operator's Setting Information;、			
	Heater Control	Triac with Zero-cross Control			
	Temp/ sensor	R type Thermocouple x 2 (for temperature control and independent overheat preventive device)			

10. Specifications

Specifications

Model		FP103	FP303	FP313	FP413
Safety Device		Self-diagnosis Functions (Temp. Sensor Failure Detection, TRIAC Short Circuit, Heater Line Disconnection, Main Relay Failure Detection, Automatic Overheat Prevention) Key Lock Function, Independent Overheat Prevention Device, ELB			
Standard	Internal dimensions (mm) ※ 2	W100 × D150 × H100	W200 × D250 × H150		W300 × D250×H150
	External dimensions (mm) ※2	W376 × D404 × H515	W446 × D504 × H565		W506 × D504×H625
	Internal capacity (L)	1.5	7.5		11.3
	Power supply (50/60Hz)	Single phase AC115V		Single phase AC220V	
	Rated current	10A(15A)	21.5A(30A)	13.5A(15A)	18A(20A)
	Weight	Approx. 32kg	Approx. 50kg	Approx. 43kg	Approx. 51kg
Accessories	Exhaust port cap	1			
	Thermal fuse	1			
	Furnace floor plate	1			
	Instruction manual	1 copy			
	V-type quick manual	1 copy			
	Warranty card	1 copy			
	Articles	※ The length of the power cord outside the unit is about 2m. ※1 Performances have been measured at the rated source voltage, single phase 115V or 220V±5%, room temperature of 23°C±5°C, humidity of 65%RH±20%, voltage of 86kPa~106kPa, and at no-load. ※2 Measurement conditions: FP103 is at 3 points in the bath, FP303,312, and 412 are compliant with JIS. ※3 Protrusions are excluded.			

11. Accessory

List of accessories

Show the list of optional accessories for this Equipment on Tables 11.1 and 11.2.1

Muffle Furnace (FP series) support a wide variety of optional parts.

※Note that some optional parts may not be installed after delivery.

Table 11.1 List of Options (installation possible after delivery)

Option	Product Code No.	Model Name	Applicable model	Remarks
Specimen tray	281310	OFP22	Common for all models	Tray to place heated specimens.
Furnace floor plate	214157	OFP68	FP103	Place specimens on this plate put on the bottom in the furnace. (145 × 90 × 6mm) (5 plates included)
Furnace floor plate	214158	OFP70	FP303/313	Place specimens on this plate put on the bottom in the furnace. (245 × 190 × 8mm) (5 plates included)
Furnace floor plate	214159	OFP72	FP413	Place specimens on this plate put on the bottom in the furnace. (290 × 245 × 8mm) (5 plates included)

Table 11.2 List of options (installation not possible after delivery)

Option	Product Code No.	Model Name	Applicable model	Remarks
Temperature output terminal (4-20mA)	214166	OFP48	Common for all models	Terminal to output 4-20mA analogue signals of the temperature sensor of the unit to the externals.
External Alarm Output Terminal	214167	OFP56	Common for all models	Output alarm signal at occurring error on this Equipment. Display its particular error on Bottom Screen.
External communication terminal (RS485)	214165	OFP46	Common for all models	Monitor operation state of this Equipment and control it remotely.
External Communication Adaptor Set	211880	OIN90	Common for all models	Connect this Equipment with PC through this adaptor for external communication. (Application software attached to this Set.)
Time-up output terminal	214168	OFP58	Common for all models	Terminal to output to the externals while END is displayed at automatic stop and the end of the programmed operation.
Operation signal output terminal	214169	OFP62	Common for all models	Terminal to output to the externals while the unit is operating.
Event output terminal	214170	OFP64	Common for all models	Terminal to output the ON-OFF signal to the externals set in different states (standby, operation, end or steps).

11. Accessory

List of optional settings

Item name	Product code	Model	Supported models	Remarks
Exhaust unit 100V	214160	OFP36	FP103/302	Used to exhaust gas generated from increased temperature in the furnace.
Exhaust unit 200V	214161	OFP38	FP313/412	
N2 gas introduction unit (with a flow meter)	214162	OFP24	FP103	This is effective for preventing oxidization in the bath and of specimens and can control flow of N2 gas to be introduced on the flow meter.
N2 gas introduction unit (with a flow meter)	214163	OFP26	FP303/312	
N2 gas introduction unit (with a flow meter)	214164	OFP28	FP413	

12. List of dangerous substances



Never process any explosive, flammable samples and also samples contained with those substances.

Explosive Substance	①Nitroglycol, Glycerine trinitrate, Cellulose Nitrate and other explosive nitrate esters
	②Trinitrobenzen, Trinitrotoluene, Picric Acid and other explosive nitro compounds
	③Acetyl Hydroperoxide, Methyl Ethyl Ketone Peroxide, Benzoyl Peroxide and other organic peroxides
	④Metallic Azide, including Sodium Azide, etc.
ExplosiveSubstances	①Metal "Lithium" ②Metal "Potassium" ③Metal "Natrium" ④Yellow Phosphorus
	⑤Phosphorus Sulfide ⑥Red Phosphorus⑦Phosphorus Sulfide
	⑧Celluloids, Calcium Carbide (a.k.a, Carbide)⑨Lime Phosphide⑩Magnesium Powder
	⑪Aluminum Powder ⑫Metal Powder other than Magnesium and Aluminum Powder
	⑬Sodium Dithionous Acid (a.k.a., Hydrosulphite)
Oxidizing Substances	①Potassium Chlorate, Sodium Chlorate, Ammonium Chlorate, and other chlorates
	②Potassium Perchlorate, Sodium Perchlorate, Ammonium Perchlorate, and other perchlorates
	③Potassium Peroxide, Sodium Peroxide, Barium Peroxide, and other inorganic peroxides
	④Potassium Nitrate, Sodium Nitrate, Ammonium Nitrate, and other nitrates
	⑤Sodium Chlorite and other chlorites
	⑥Calcium Hypochlorite and other hypochlorites
Flammable Substances	① Ethyl Ether, Gasoline, Acetaldehyde, Propylene Chloride, Carbon Disulfide, and other substances with ignition point at a degree 30 or more degrees below zero.
	②n-hexane, Ethylene Oxide, Acetone, Benzene, Methyl Ethyl Ketone and other substances with ignition point between 30 degrees below zero and less than zero.
	③Methanol, Ethanol, Xylene, Pentyl n-acetate, (a.k.a.amyl n-acetate) and other substances with ignition point between zero and less than 30 degrees.
	④Kerosene, Light Oil, Terebinth Oil, Isopenthyl Alcohol(a.k.a. Isoamyl Alcohol), Acetic Acid and other substances with ignition point between 30 degrees and less than 65 degrees.
Combustible Gas	Hydrogen, Acetylene, Ethylene, Methane, Ethane, Propane, Butane and other gases combustible at 15°C at one air pressure.

Excerpt from Table 1, Hazardous Substances, of Cabinet Order of the Occupational Safety and Health Law (substances related to Articles 1, 6, and 9)

13. Standard setup manual

* Install this Equipment according to following format (Check the format for options or customized specifications)

Model	Serial number	Installation Date	Charged Personnel or Company Name for Installation	Installation proved by	Judgment

No.	Item	Implementation Method	Chapter No. & Reference page of Instruction Manual	Judgment
Specifications				
1	Accessories	Check for number of accessories Against to Accessories Column.	10. Specification P.60	
2	Installation	<ul style="list-style-type: none"> Check room environment visually. Caution: Take care for environment Make installation space. 	2. Before operating the Equipment <ul style="list-style-type: none"> Precautions when installing t... P.6~9	
Equipment Operation				
1	Voltage of Power Source	<ul style="list-style-type: none"> Measure line voltage (power distribution board of facilities, receptacle, etc.) with voltmeter. Measure line voltage during operation. (Must meet required voltage.) Caution: Check receptacle rating or breaker on power switch board rating to meet this Equipment requirement.	2. Before operating the Equipment <ul style="list-style-type: none"> Connect Power Cord/Cable to receptacle or Must connect grounding wire Pay attention to... P.7 P.7 P.8 P.60 10.Specification Power Supply	
2	Operation checking	<ul style="list-style-type: none"> Explain about names and functions of each part Execution of auto stop operation Set temp.: 150°C Setting time :30 min 	3. Names and functions of each part <ul style="list-style-type: none"> Main unit, operational panel P.10~11 P.21~23 4. Operating procedure <ul style="list-style-type: none"> Auto stop operation 	
Description				
1	Operational descriptions	Explain operations of each component and handling precautions according to Instruction Manual.	4. Operating procedure <ul style="list-style-type: none"> Prior confirmation P.13 Date & Time setting P.14~49 5. Handling precautions <ul style="list-style-type: none"> Warnings P.50~53 Cautions P.69 13. List of dangerous substances 13.1 Table of dangerous	
2	Error Codes	Explain about error codes and procedures for reset according to Instruction Manual.	8. When a trouble occurs <ul style="list-style-type: none"> Message error table P.56~57 Troubleshooting P.58 	
3	Maintenance and inspection	Explain operations of each component according to Instruction Manual.	6. Maintenance method <ul style="list-style-type: none"> Daily inspection/ maintenance P.54 	
4	Completion of installation Entries	<ul style="list-style-type: none"> Fill in Installation Date and Charged Personnel or Company Name on OK and Service seal of this Equipment. Fill in necessary information to Warranty Card and hand it over to customer. Explain how to contact with service personnel. 	9. After sales service and warranty <ul style="list-style-type: none"> Request to repair parts P.59 	

Programming sheet

Control №

Model name		Date of preparation	(Y) (M) (D)
Program pattern number		Prepared by	

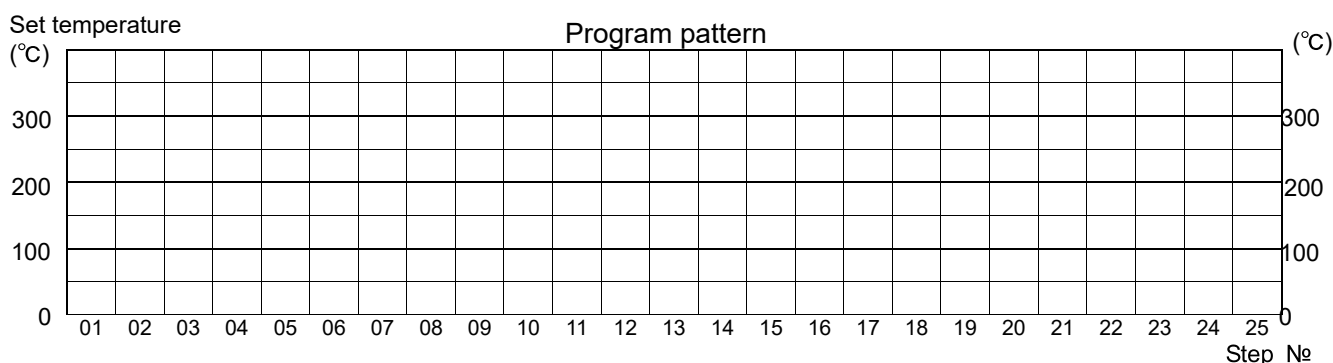

Pattern number	Step	Set temperature	Time	Repeat dstn	Number of repetitions	Wait	Event			End
P** : 00	P02 : **	TEMP	TIME	REP	REP	WAIT	EVENT			END
		(°C)	Hr : Min	STEP	COUNT	ON/OFF	1	2	3	:ST
	01		:							
	02		:							
	03		:							
	04		:							
	05		:							
	06		:							
	07		:							
	08		:							
	09		:							
	10		:							
	11		:							
	12		:							
	13		:							
	14		:							
	15		:							
	16		:							
	17		:							
	18		:							
	19		:							
	20		:							
	21		:							
	22		:							
	23		:							
	24		:							
	25		:							
Remarks										

Note: Event is optional item. Duplicate and use this sheet.

Limited liability

Be sure to use this Equipment strictly following the handling and operating instructions in this Instruction Manual.

Yamato Scientific Co., Ltd. assumes no responsibility for accident or malfunction caused by use of this Equipment in any way not specified in this Instruction Manual.

Never attempt to perform matters prohibited in this Instruction Manual.

Otherwise, unexpected accident may result.

Notice

- Descriptions in this Instruction Manual are subject to change without notice.
- WE, as Yamato Scientific Co., Ltd. will replace this Instruction Manual with missing page or paging disorder.

Instruction Manual
Muffle Furnace
FP103/303/313/413

First Edition September 16, 2020
Revised on

Yamato Scientific America, Inc.
925 Walsh Avenue, Santa Clara,
CA 95050, U.S.A
<http://www.yamato-usa.com>
Toll Free: 1-800-2-YAMATO(1-800-292-6286)