

DIAPHRAGM PUMPS

ME 2 NT
ME 4 NT - ME 4S NT
MZ 2 NT - MZ 2S NT
MZ 2D NT
ME 8 NT - ME 8S NT
MD 4 NT - MD 4S NT
MV 2 NT
ME 4R NT
MD 4CRL NT



Instructions for use



Dear customer,

Your VACUUBRAND diaphragm pumps are designed to provide you with many years of trouble-free service with optimal performance. Our many years of practical experience allow us to provide a wealth of application and safety information. Please read these instructions for use before the initial operation of your pump.

VACUUBRAND diaphragm pumps combine our many years of experience in design, construction and practical operation, with the latest developments in material and manufacturing technology.

Our quality maxim is the "zero defect" principle:

Every diaphragm pump, before leaving our factory, is tested intensively, including an endurance run of 14 hours. Any faults, even those which occur rarely, are identified and can be eliminated immediately.

After completion of the endurance run, every pump is tested, and must achieve specifications before shipment.

We are committed to providing our customers only pumps that meet this high quality standard.

While our pumps cannot eliminate all of your work, we design, manufacture and test them to ensure that they will be an effective and trouble-free tool to assist you in that work.

Yours,

VACUUBRAND GMBH + CO KG

After sales service:

Contact your local dealer or call +49 9342 808-5500.

Trademark index:

VACUU·LAN® (US-Reg.No 3,704,401), VACUU·BUS®, VACUU·CONTROL®, VACUU·SELECT® (US-Reg.No 5,522,260), VARIO® (US-Reg.No 3,833,788), VACUUBRAND® (US-Reg.No 3,733,388), VACUU·VIEW®, GREEN VAC® (US-Reg.No. 4,924,553), VACUU·PURE® (US-Reg.No. 5,559,614) and also the shown company logos are registered trademarks of VACUUBRAND GMBH + CO KG in Germany and/or other countries.

DE

Achtung: Die vorliegende Betriebsanleitung ist nicht in allen EU-Sprachen verfügbar. Der Anwender darf die beschriebenen Geräte nur dann in Betrieb nehmen, wenn er die vorliegende Anleitung versteht oder eine fachlich korrekte Übersetzung der vollständigen Anleitung vorliegen hat. Die Betriebsanleitung muss vor Inbetriebnahme der Geräte vollständig gelesen und verstanden werden, und alle geforderten Maßnahmen müssen eingehalten werden.

 "Sicherheitshinweise für Vakuumgeräte"

EN

Attention: This manual is not available in all languages of the EU. The user must not operate the device if he does not understand this manual. In this case a technically correct translation of the complete manual has to be available. The manual must be completely read and understood before operation of the device and all required measures must be applied.

 "Safety instructions for vacuum equipment"

FR

Attention: Le mode d'emploi présent n'est pas disponible dans toutes les langues d'Union Européenne. L'utilisateur ne doit mettre le dispositif en marche que s'il comprend le mode d'emploi présent ou si une traduction complète et correcte du mode d'emploi est sous ses yeux. Le dispositif ne doit pas être mis en marche avant que le mode d'emploi ait été lu et compris complètement et seulement si le mode d'emploi est observé et tous les mesures demandées sont prises.

 «Avis de sécurité pour des dispositifs à vide»

BG

Внимание: Тези инструкции не са преведени на всички езици от ЕО. Потребителят не бива да работи с уреда, ако не разбира инструкциите за ползване. В този случай е необходимо да бъде предоставен пълен технически превод на инструкциите за ползване. Преди работа с уреда е задължително потребителят да прочете изцяло инструкциите за работа.

 "Указания за безопасност за вакуумни уреди"

CN

注意：该操作手册不提供所有的语言版本。操作者在没有理解手册之前，不能操作该设备。在这种情况下，需要有一个整个操作手册技术上正确的翻译。在操作该设备前，必须完全阅读并理解该操作手册，必须实施所有需要的测量。

 真空设备的安全信息

CZ

Upozornění :Tento návod k použití není k dispozici ve všech jazycích Evropské unie. Uživatel není oprávněn požit přístroj pokud nerozumí tomuto návodu. V takovém případě je nutno zajistit technicky korektní překlad manuálu do češtiny. Návod musí být uživatelem prostudován a uživatel mu musí plně porozumět před tím než začne přístroj používat. Uživatel musí dodržet všechna příslušná a požadovaná opatření.

 "Bezpečnostní upozornění pro vakuové přístroje".

DA

Bemærk: Denne manual foreligger ikke på alle EU sprog. Brugeren må ikke betjene apparatet hvis manualen ikke er forstået. I det tilfælde skal en teknisk korrekt oversættelse af hele manual stilles til rådighed. Manual skal være gennemlæst og forstået før apparatet betjenes og alle nødvendige forholdsregler skal tages.

 »Sikkerhedsregler for vakuumudstyr«

EE

Tähelepanu! Käesolev kasutusjuhend ei ole kõigis EL keeltes saadaval. Kasutaja ei tohi seadet käsitseda, kui ta ei saa kasutusjuhendist aru. Sel juhul peab saadaval olema kogu kasutusjuhendi tehniliselt korrektne tõlge. Enne seadme kasutamist tuleb kogu juhend läbi lugeda, see peab olema arusaadav ning kõik nõutud meetmed peavad olema rakendatud.

 "Ohutusnõuded vaakumseadmetele"

ES

Atención: Este manual no está disponible en todos los idiomas de UE. El usuario no debe manejar el instrumento si no entiende este manual. En este caso se debe disponer de una traducción técnicamente correcta del manual completo. El manual debe ser leído y entendido completamente y deben aplicarse todas las medidas de seguridad antes de manejar el instrumento.

 "Notas sobre la seguridad para equipos de vacío"

FI

Huomio: Tämä käyttöohje ei ole saatavilla kaikilla EU:n kielillä. Käyttäjä ei saa käyttää laitetta, jos hän ei ymmärrä tätä ohjekirjaa. Tässä tapauksessa on saatavilla oltava teknisesti oikein tehty ja täydellinen ohjekirjan käännös. Ennen laitteen käyttöä on ohjekirja luettava ja ymmärrettävä kokonaan sekä suoritettava kaikki tarvittavat valmistelut ja muut toimenpiteet.

 "Vakuumlaitteen turvallisuustiedot"

GR

Προσοχή! : Οι οδηγίες αυτές δεν είναι διαθέσιμες σε όλες τις γλώσσες της Ευρωπαϊκής Ένωσης. Ο χρήστης δεν πρέπει να θέσει σε λειτουργία την συσκευή αν δεν κατανοήσει πλήρως τις οδηγίες αυτές. Σε τέτοια περίπτωση ο χρήστης πρέπει να προμηθευτεί ακριβή μετάφραση του βιβλίου οδηγιών. Ο χρήστης πρέπει να διαβάσει και να κατανοήσει πλήρως τις οδηγίες χρήσης και να λάβει όλα τα απαραίτητα μέτρα πριν θέσει σε λειτουργία την συσκευή.

 "Υποδείξεις ασφάλειας για αντλίες κενού"

HR

Pažnja: ove upute ne postoje na svim jezicima Europske Unije. Korisnik nemora raditi sa aparatom ako ne razumije ove upute. U tom slučaju tehnicki ispravni prijevod cijelih uputstava mora biti na raspolaganju. Uputstva moraju biti cijela procitana i razumljiva prije rada sa aparatom i sve zahtijevane mjere moraju biti primjenjene.

 "Sigurnosne napomene za vakuumske uređaje"

HU

Figyelem! Ez a kezelési utasítás nem áll rendelkezésre az EU összes nyelvén. Ha a felhasználó nem érti jelen használati utasítás szövegét, nem üzemeltetheti a készüléket. Ez esetben a teljes gépkönyv fordításáról gondoskodni kell. Üzembe helyezés előtt a kezelőnek végig kell olvasnia, meg kell értenie azt, továbbá az üzemeltetéshez szükséges összes mérést el kell végeznie.

 "A vákuum-készülékekkel kapcsolatos biztonsági tudnivalók"

IT

Attenzione: Questo manuale non è disponibile in tutte le lingue della Comunità Europea (CE). L'utilizzatore non deve operare con lo strumento se non comprende questo manuale. In questo caso deve essere resa disponibile una traduzione tecnicamente corretta del manuale completo. Il manuale deve essere completamente letto e compreso prima di operare con lo strumento e devono essere applicati tutti gli accorgimenti richiesti.

 "Istruzioni di sicurezza per apparecchi a vuoto"

JP

注意：この取扱説明書はすべての言語で利用可能ではありません。もしこの取扱説明書を理解できないならば、ユーザーは装置を操作してはなりません。この場合、技術的に正しい翻訳がなされた完全なマニュアルを用意しなければなりません。装置を作動する前にマニュアルを完全に読み、そして理解されなくてはなりません。そして、すべての要求される対策を講じなければなりません。

 真空装置を安全に取り扱うために

KR

주의 : 이 매뉴얼은 모든 언어로 번역되지는 않습니다. 만약 이 매뉴얼의 내용을 충분히 인지하지 못했다면 기기를 작동하지 마십시오. 매뉴얼의 내용을 기술적으로 정확하게 번역한 경우에 이용하십시오. 기기를 사용하기 전에 이 매뉴얼을 충분히 읽고 이해하고 모든 요구되는 사항들을 적용해야 합니다.

 진공 장비에 대한 안전 정보

LT

Dėmesio: šis vadovas nėra pateikiamas visomis ES kalbomis. Naudotojui draudžiama eksploatuoti įtaisą, jeigu jis nesupranta šio vadovo. Tokiu atveju reikia turėti viso vadovo techniškai taisyklingą vertimą. Vadovą būtina visą perskaityti ir suprasti pateikiamas instrukcijas prieš pradėdant eksploatuoti įtaisą, bei imtis visų reikiamų priemonių.

 "Vakuuminės įrangos saugos informacija"

LV

Uzmanību: Lietotāja instrukcija nav pieejama visās ES valodās. Lietotājs nedrīkst lietot iekārtu, ja viņš nesaprot lietotāja instrukcijā rakstīto. Šādā gadījumā, ir nepieciešams nodrošināt tehniski pareizu visas lietotāja instrukcijas tulkojumu. Pirms sākt lietot iekārtu, un, lai izpildītu visas nepieciešamās prasības, iekārtas lietotāja instrukcija ir pilnībā jāizlasa un jāsaprot.

 "Vakuuma iekārtu drošības noteikumi"

NL

Attentie: Deze gebruiksaanwijzing is niet in alle talen van de EU verkrijgbaar. De gebruiker moet niet met dit apparaat gaan werken als voor hem/haar de gebruiksaanwijzing niet voldoende duidelijk is. Bij gebruik van deze apparatuur is het noodzakelijk een technisch correcte vertaling van de complete gebruiksaanwijzing te hebben. Voor het in gebruik nemen van het apparaat moet de gebruiksaanwijzing volledig gelezen en duidelijk zijn en dienen alle benodigde maatregelen te zijn genomen.

 "Veiligheidsvoorschriften voor vacuümapparaten"

PL

Uwaga!! Ta instrukcja nie jest dostępna we wszystkich językach Unii Europejskiej. Użytkownik nie może rozpocząć pracy z urządzeniem dopóki nie przeczytał instrukcji i nie jest pewien wszystkich informacji w niej zawartych. Instrukcja musi być w całości przeczytana i zrozumiana przed podjęciem pracy z urządzeniem oraz należy podjąć wszystkie niezbędne kroki związane z prawidłowym użytkowaniem.

 "Wskazówki bezpieczeństwa do urządzeń próżniowych"

PT

Atenção: Este manual não está disponível em todas as línguas da UE. O usuário não deve utilizar o dispositivo, se não entender este manual. Neste caso, uma tradução tecnicamente correta do manual completo tem de estar disponível. O manual deve ser lido e entendido completamente antes da utilização do equipamento e todas as medidas necessárias devem ser aplicadas.

 "Informação de Segurança para Equipamento que funciona a Vácuo"

RO

Atentie: Acest manual nu este disponibil in toate limbile EU. Utilizatorul nu trebuie sa lucreze cu aparatul daca nu intelege manualul. Astfel, va fi disponibile o traducere corecta si completa a manualului. Manualul trebuie citit si inteles in intregime inainte de a lucra cu aparatul si a luat toate masurile care se impun.

 "Instrucțiuni de siguranță pentru aparatele de vidare"

RU

Внимание: Эта инструкция по эксплуатации не имеется на всех языках. Потребителю не дозволено эксплуатировать данный прибор, если он не понимает эту инструкцию. В этом случае нужен технически правильный перевод полной инструкции. Прежде чем использовать этот прибор, необходимо полностью прочитать и понять эту инструкцию и принять все необходимые меры.

 "Указания по технике безопасности при работе с вакуумными устройствами"

SE

Varning: Denna instruktion är inte tillgänglig på alla språk inom EU. Användaren får inte starta utrustningen om hon/han inte förstår denna instruktion. Om så är fallet måste en tekniskt korrekt instruktion göras tillgänglig. Instruktionen måste läsas och förstås helt före utrustningen tas i drift och nödvändiga åtgärder göres.

 "Säkerhetsinformation för vakuumutrustning"

SI

Pozor: Ta navodila niso na voljo v vseh jezikih EU. Uporabnik ne sme upravljati z napravo, če ne razume teh navodil. V primeru nerazumljivosti mora biti na voljo tehnično pravilen prevod. Navodila se morajo prebrati in razumeti pred uporaba naprave, opravljene pa moraja biti tudi vse potrebne meritve.

 "Varnostni nasveti za vakuumske naprave"

SK

Upozornenie: Tento manuál nie je k dispozícii vo všetkých jazykoch EÚ. Užívateľ nesmie obsluhovať zariadenie, pokiaľ nerozumie tomuto manuálu. V takomto prípade musí byť k dispozícii technicky správny preklad celého manuálu. Pred obsluhou zariadenia je potrebné si prečítať celý manuál a porozumieť mu, a musia byť prijaté všetky opatrenia.

 "Bezpečnostné pokyny pre vákuové zariadenia"

TR

Dikkat : Bu kullanım kitabı, tüm dillerde mevcut değildir. Kullanıcı, bu kullanım kitabını anlayamadıysa cihazı çalıştırmamalıdır. Bu durumda, komple kullanım kitabının, teknik olarak düzgün çevirisinin bulunması gerekir. Cihazın çalıştırılmasından önce kullanım kitabının komple okunması ve anlaşılması ve tüm gerekli ölçümlerin uygulanması gerekir.

 "Vakumlu cihazlar için güvenlik uyarıları"

Contents



Safety information!	9
Important information!	9
General information.....	11
Intended use.....	11
Improper use	12
Setting up and installing the equipment	14
Ambient conditions	16
Operating conditions	16
Safety during operation	18
Maintenance and repair.....	21
Additional safety information for ME 4R NT	23
⊕ Important information: Equipment marking (ATEX).....	24
Technical data	26
General technical data valid for all pumps	26
Gas inlet temperatures	26
Wetted parts	32
Abbreviations.....	33
Pump parts	34
Use and operation	41
Installation	41
Vacuum connection (inlet).....	42
Connecting the outlet	43
Notes prior to the use of the manometers (ME 4R NT).....	46
Electrical connection	47
During operation.....	48
Shutdown & storage	51
Accessories	53
Troubleshooting	55
Replacing diaphragms and valves	57
Checking diaphragms and valves (except MZ 2D NT).....	59
Replacing the valves and assembling the pump heads	67
Assembling the connecting hose	70
Checking diaphragms and valves (MZ 2D NT)	72
Replacing the valves and assembling the pump heads	76
Assembling the connecting hose (MZ 2D NT).....	79
Replacing the fuse.....	80
Repair - Maintenance - Return - Calibration	82

Warranty	83
Declarations and certificates.....	84

Safety information!

Important information!

WARNING

-  **Keep this manual complete and accessible to personnel at all times!**
-  **Read this manual carefully before installing or operating the equipment. Observe the instructions contained in this manual.**
-  **Do not modify the equipment without authorization.**

NOTICE

This manual is an integral part of the equipment described therein. It describes the safe and proper use of the vacuum pump.

Make operating personnel aware of dangers arising from the pump and the pumped substances.

VACUUBRAND disclaims any liability for inappropriate use of these pumps and for damage from failure to follow instructions contained in this manual.

This manual is only to be used and distributed in its complete and original form. It is strictly the users' responsibility to check carefully the validity of this manual with respect to his product.

Manual-no.: 20901070

The document "Safety information for vacuum equipment" is part of this manual! Read the "Safety information for vacuum equipment" and observe the instructions contained therein!

The following signal word panels and safety symbols are used throughout this manual:



This is the safety alert symbol. It is used to alert you to potential personal injury hazards. Obey all safety messages that follow this symbol to avoid possible injury and death.



➔ DANGER indicates a hazardous situation which, if not avoided, will result in death or serious injury.



☞ WARNING indicates a hazardous situation which, if not avoided, could result in death or serious injury.



• CAUTION indicates a hazardous situation which, if not avoided, could result in minor or moderate injury.



NOTICE is used to address practices not related to personal injury.



Caution! Hot surface!



Caution! Electrical voltage!



General danger sign.



Disconnect equipment from AC power.



Read manual.



Electronic components must not be disposed of in the domestic waste at the end of their service life. Used electronic devices contain harmful substances that can cause damage to the environment or human health. End users are legally obliged to take used electric and electronic devices to a licensed collection point.

Formatting used in this manual:

Note: The signal word panels in all sections of this manual always refer to all paragraphs of the same format (➔ / ☞ / • / plain text) following each signal word panel.

General information

NOTICE

Remove all packing material from the packing box. Remove the product from its packing-box and retain all packaging until the equipment is inspected and tested. Remove the protective caps from the inlet and outlet ports and retain for future use. Inspect the equipment promptly and carefully.

If the equipment is damaged, notify the supplier and the carrier in writing within three days. Retain all packing material for inspection. State the item number of the product together with the order number and the supplier's invoice number. Failure to check and give notice of damage will void any and all warranty claims for those deficiencies.

Replace the protective caps, if the equipment is not used immediately. Store the equipment in dry and non-corrosive conditions (see also "Technical data", pg. 26).

WARNING

☞ **Do not use any damaged equipment.**

CAUTION

- Use the mounted handle when moving the pump.

Intended use

The vacuum pump may only be used indoors in a dry, non-explosive atmosphere.

An attached vapor condenser (accessory) is exclusively intended for the condensation of vapors and for collecting liquids.

WARNING

Intended use also includes:

- ☞ Observing the information in the document Safety information for vacuum equipment.
- ☞ Observing the manual.
- ☞ Observing the manual of connected components.
- ☞ Regularly inspecting the vacuum pump according to its operating conditions and have this carried out by qualified personnel.

- ☞ Using only original VACUUBRAND parts and original accessories / approved accessories or spare parts.

Any other use is considered improper use.

Improper use

Incorrect use or any application which does not correspond to the technical data may result in injury or damage to property.

Improper use includes:

- ☞ Using the product contrary to its intended use,
 - ☞ Using the product in non-commercial environments, unless the necessary protective measures and precautions have been taken by the company,
 - ☞ Operation under inadmissible environmental and operating conditions,
 - ☞ Operation despite obvious errors or defective safety devices,
 - ☞ Unauthorized extensions, conversions, or repairs, in particular when these impair safety,
 - ☞ The use of unauthorized accessories or spare parts,
 - ☞ Usage despite incomplete assembly,
 - ☞ operation by insufficiently trained or qualified personnel,
 - ☞ Switching on/off with tools or one's foot,
 - ☞ Operation with sharp-edged objects,
 - ☞ Pulling plug-in connections on the cable out of the socket,
 - ☞ Extracting or conveying solids or liquids.
-
- ☞ Do not use the pump or any system parts on humans or animals.
-
- ☞ Ensure that the individual components are only connected, combined and operated according to their design and as indicated in the instructions for use. Use only **original manufacturer's spare parts and ac-**



cessories. Otherwise the safety and performance of the equipment, as well as the electromagnetic compatibility of the equipment might be reduced.

The CE mark or the cTÜVus mark may be voided if not using original manufacturer's spare parts.

- ☞ Comply with all notes on correct vacuum and electrical connections; see section "Use and operation", pg. 41.
- ☞ Do not use the pump to generate pressure.
- ☞ The pumps are designed for **ambient temperatures** during operation between +50 °F and +104 °F (+10 °C and +40 °C). Periodically check maximum temperatures if installing the pump in a cabinet or a housing. Make sure ventilation is adequate to maintain recommended operating temperature. Install an external automatic ventilation system if necessary. If pumping hot process gases, make sure that the maximum permitted gas inlet temperature is not exceeded. The maximum permitted gas inlet temperature depends on several parameters like inlet pressure and ambient temperature (see "Technical data", pg. 26).
- ☞ Particles and dust must not enter the pump.
- ☞ Do not pump liquids.

CAUTION

- Ensure that the pump is chemically resistant to the pumped substances prior to operation.

NOTICE

Use the equipment **only as intended**, that is, for generation of vacuum in vessels designed for that purpose. Any other use will automatically invalidate all warranty and liability claims. Remain aware of safety and risks.

Setting up and installing the equipment

DANGER

➔ Equipment must be connected only to a **suitable electrical supply** and a suitable ground point. As such, the plug must be plugged into an outlet that is properly grounded. Failure to connect the motor to ground may result in deadly electrical shock.

The supply cable may be fitted with a molded European IEC plug or a plug suitable for your local electrical supply. The cable contains wires color coded as follows: green or green and yellow: ground; blue or white: neutral; brown or black: hot.

WARNING

☞ Due to the high compression ratio, the pump may generate overpressure at the outlet. Check pressure compatibility with system components (e.g., exhaust pipeline or exhaust valve) at the outlet.

☞ Do not permit any **uncontrolled pressurizing**. Make sure that the exhaust tubing cannot become blocked to avoid a **risk of bursting!**

☞ Keep the electrical power cord away from heated surfaces.

☞ Keep the electrical power cord away from hot surfaces.

CAUTION

- Provide a firm, level platform for the equipment. Check that the system which you are going to evacuate is mechanically stable. Check that all fittings are secure. Ensure a stable position of the pump without any mechanical contact other than the pump feet.

- Comply with **maximum permissible pressures** at inlet and outlet and with **maximum permissible pressure differences** between inlet and outlet. See section "Technical data", pg. 26. Do not operate the pump with overpressure at the inlet.

- Avoid overpressure of more than 17.5 psi absolute (1.2 bar absolute) in the event that inert gas is connected to the pump, or to a venting valve.

- **Note:** Flexible elements will shrink when evacuated.
- Connect hoses gas tight at inlet and outlet of the pump and secure against loosening, for example, with a hose clamp.
- Ensure that no foreign objects can be drawn into the pump.
- Check the power source and the pump's rating plate to be sure that the power source and the equipment match in voltage, phase, and frequency.
- On pumps with a dual-voltage motor, check that the voltage selection switch is set correctly. Do not change the setting of the voltage selection switch while the pump is connected to AC power. Unplug the pump before setting the voltage selection switch. **Note:** If the pump is switched on with wrong voltage selection, the motor may be damaged!

NOTICE

Make sure ventilation is adequate to maintain recommended operating temperature. Keep a minimum distance of 2 in (5 cm) between the cooling fan and surrounding items (e.g., housing, walls, etc.), or else install an external automatic ventilation system. Check fan regularly for dust/dirt. Clean fan guard grill if necessary to avoid a reduction of ventilation.

The mains plug is a disconnecting device to separate the pump from the supply voltage. Ensure that the mains plug is easily accessible at all times to allow the separation of the device from the power supply.

Use only hoses at the inlet and outlet of the pump with an inner diameter at least as large as the diameter of the pump's tubing (to avoid overpressure at the outlet, and reduction of pumping speed at the inlet).

Allow the equipment to equilibrate to ambient temperature if you bring it from cold environment into a room prior to operation. Notice if there is water condensation on cold surfaces.

Comply with all **applicable and relevant safety requirements** (regulations and guidelines). **Implement the required actions and adopt suitable safety measures.**

Ambient conditions



➔ Do not reach for this product if it has fallen into liquid. There is a risk of deadly electrical shock. Unplug the system immediately.



☞ Do not use this product in an area where it can fall or be pulled into water or other liquids.



- This product may only be used indoors in a non-explosive atmosphere, and in a dry environment. Adopt suitable measures in case of differences from recommended conditions, e.g., installation in higher altitudes (risk of insufficient cooling), conductive pollution or external condensation on the pump.
- Do not operate this product near flames.

NOTICE

To the best of our knowledge the equipment is in compliance with the requirements of the applicable EC-directives and harmonized standards (see "Declaration of Conformity") with regard to design, type and model. Directive EN 61010-1 gives in detail the conditions under which the equipment can be operated safely (see also IP degree of protection, "Technical data", pg. 26).

Operating conditions



➔ These pumps are not approved for operation in potentially explosive atmospheres. **Do not operate the pumps in potentially explosive atmospheres.**

➔ Pumps **without the "Ex" mark on the rating plate are not approved for the pumping of potentially explo-**

sive atmospheres. Do not pump potentially explosive atmospheres with those pumps.

- ➔ Pumps bearing the "⊕x" mark on their rating plates are **approved for the pumping of potentially explosive atmospheres** according to their ATEX classification imprinted on their rating plate, but they are **not approved for operation in potentially explosive atmospheres** (see section "⊕x Important information: Equipment marking (ATEX)", pg. 24).

The user is responsible for assessing the risks posed by the equipment in such a way that any safety measures necessary for installation and safe operation can be implemented.

- ➔ The pumps are **not suitable** to pump any of the substances listed below.

Do not pump:

- **unstable substances**
- substances which react explosively under **impact** (mechanical stress) without air
- substances which react explosively when being exposed to **elevated temperatures** without air,
- substances subject to **auto-ignition**,
- substances which are **flammable without air**
- **explosive substances**.

- ➔ The pumps are **not approved** for operation below ground. **Do not operate** the pump **below ground**.



- **Do not pump** substances which may form **deposits** inside the pump. The pumps are not suitable for pumping substances which may form deposits inside the pump. Deposits and condensate in the pump may lead to increased temperatures even to the point of exceeding the maximum permitted temperatures.

- Check the inlet and outlet of the pump, if there is a danger of forming **deposits** inside the pump, e.g., in

the pump chambers (the pump chamber is the part between diaphragm and head cover. See section “Replacing diaphragms and valves”, pg. 57). Inspect the pump chambers regularly and clean if necessary.

- **Consider interactions and chemical reactions of the pumped media.** Ensure that the materials of the pump’s wetted parts are compatible with the pumped substances, see section “Technical data”, pg. 26. When changing the substances pumped, we recommend purging the pump with air or inert gas prior to changing the pumped media. Purging the pump will pump out residues and it will reduce the possibility of reactions of the pumped substances with each other and with the pump’s materials.

Safety during operation

DANGER

- ➔ Adopt suitable measures to prevent the release of dangerous, toxic, explosive, corrosive, noxious or polluting fluids, vapors and gases. To prevent any emission of such substances from the pump outlet, install an appropriate collecting and disposal system and take protective action for pump and environment.
- ➔ You must take suitable precautions to prevent any formation of explosive mixtures in the pump chamber or at the outlet of the pump. In case, e.g., of a diaphragm failure, mechanically generated sparks, hot surfaces or static electricity may ignite these mixtures. Use inert gas for venting, if necessary.
- ➔ Drain appropriately or otherwise remove any potentially explosive mixtures at the outlet of the pump, or dilute them to non-explosive concentrations.
- ➔ Never operate this pump if it has a damaged cord or plug.

WARNING

- ☞ If the pump is not working properly, has been dropped or has fallen into water, contact your pump service provider.

- ☞ Prevent any part of the human body from coming into contact with vacuum.
- ☞ If there is an exhaust isolation valve, make sure that you cannot operate the equipment with the valve closed to avoid a **risk of bursting!**
- ☞ Always provide a free and pressureless exhaust outlet to avoid damage to pump valves and risk of bursting.
- ☞ **Attention:** Dust-laden gases, deposits and condensed solvent vapor can restrict air flow out a (optional) silencer. The resultant back pressure can lead to damage of pump bearings, diaphragms, and valves. Under those conditions, a silencer must not be used. Instead, use a hose nozzle (see “Accessories”, pg. 53) or use the enclosed hose nozzle (ME 2 NT, ME 4 NT, MZ 2 NT, ME 8 NT) at the outlet.

- ☞ Comply with applicable regulations when disposing of chemicals. Take into consideration that chemicals may be contaminated. Take adequate precautions to protect people from the effects of dangerous substances (chemicals, thermal decomposition products of fluoroelastomers). Use appropriate protective clothing and safety goggles.

- ☞ Interruption of the pump (e.g., due to power failure), failure of connected components or of parts of the supply, or change in parameters must not be allowed to lead to dangerous conditions. In case of a diaphragm failure or in case of a leak in the manifold, pumped substances might be released into the environment or into the pump housing or motor.
Comply with all notes regarding proper use of the pumps, as well as operation and maintenance guidance.

- ☞ The residual **leak rate of the equipment** might render possible an exchange of gas, albeit extremely slight, between the environment and the vacuum system.
Adopt suitable measures to prevent contamination of the pumped substances or the environment.

CAUTION

- Ensure that no parts of your clothing, hair or fingers can be caught or drawn in at the inlet of the pump. Never insert fingers or drop any other object into the inlet or outlet.



- Pay attention to the safety symbol "hot surfaces" on the equipment. Depending on operation conditions and ambient conditions dangers due to hot surfaces may arise. Hot parts may cause burns if touched. Adopt suitable measures to prevent any danger arising from hot surfaces. Ensure that hot surfaces of the pump do not cause burns. Provide a suitable contact guard if necessary.
- **ME 2 NT / ME 4(S) NT / ME 8(S) NT / MZ 2(S) NT:** The surface temperature of the optional silencer in particular might be elevated in case of high gas throughput. In case of high gas throughput, replace the optional silencer with a hose nozzle.

NOTICE

Prevent the backpressure of gases and the backflow of condensates at the outlet.

Provide appropriate protective measures to allow for the possibility of failure and **malfunction**. The protective measures must also allow for the requirements of the respective application.

In case of overload, the motor is shut down by a **self-hold thermal cutout** in the winding.

Note: Only manual reset is possible. Switch off the pump and disconnect from the power source. Identify and eliminate the cause of failure. Wait approx. five minutes before restarting the pump.

CAUTION

- **Note:** In case of **supply voltage below 115 V**, the lock of the cutout might be impaired and the pump may restart on its own after sufficient cooling down. Take appropriate precautions, if an automatic restart of the pump may lead to a dangerous situation (e.g., switch off the pump and disconnect from the power source).

Maintenance and repair

NOTICE

In order to comply with laws (occupational, health and safety regulations, safety at work law and regulations for environmental protection) vacuum pumps, components and measuring instruments can only be returned when certain procedures (see section “Repair - Maintenance - Return - Calibration”, pg. 82) are followed.

Take advantage of our service seminars, which put special focus on the maintenance and repair of vacuum pumps. For details and for the online “Instructions for repair” manual see www.vacuubrand.com.

In normal use, the lifetime of the diaphragms and valves is typically 15,000 operating hours. Bearings have a typical durability of 40000 h. Motor capacitors have a typical durability in the range of 10000 to 40000 h depending strongly on operation conditions including ambient temperature, humidity or load.

! DANGER



- ➔ **Ensure that the pump cannot be operated accidentally. Never operate the pump if covers or other parts of the pump are disassembled.**
- ➔ **Switch off the pump. Disconnect the electrical power cord and wait five seconds** before starting maintenance to allow the capacitors to discharge.
- ➔ **Note:** The pump may be contaminated with process chemicals, which have been pumped during operation. Ensure that the pump is completely decontaminated before maintenance commences.

! WARNING

- ☞ Take adequate precautions to protect people from the effects of dangerous substances if contamination has occurred. Use appropriate protective clothing, safety goggles and protective gloves.
- ☞ **Wear parts have to be replaced regularly.**
- ☞ **Never operate a defective or damaged pump.**
- ☞ Check every motor capacitor regularly by measuring its

capacity and estimating its time in operation. Replace old capacitors early enough to prevent a failure in operation. If an old motor capacitor fails, the capacitor may get hot. It may even melt or emit a flame, which could be **dangerous for persons and equipment in the vicinity**. The capacitors have to be replaced by an electrician.

- ☞ Vent the pump before starting maintenance. Isolate the pump and other components from the vacuum system. Allow sufficient cooling of the pump. Drain condensate, if applicable.

NOTICE

Clean polluted surface with a clean, slightly moistened cloth. To moisten the cloth we recommend water or mild soap.

Interventions on the device

- ☞ Work on the equipment may be performed only by a qualified person.
- ☞ Work on electrical equipment in particular may be performed only by qualified electricians.
- ☞ Ensure that maintenance is done only by suitably trained and supervised technicians or at least by an instructed person.

Ensure that the maintenance technician is familiar with the safety procedures which relate to the products processed by the pumping system.

Only dismantle the pump as far as necessary.

Additional safety information for ME 4R NT

Intended use

WARNING

- ☞ Comply with all notes on how to connect the ME 4R NT correctly to vacuum and pressure systems; see section “Use and operation”, pg. 41.

NOTICE

Use the equipment **only as intended**, that is, for generation of vacuum or for compression of gases in vessels designed for that purpose. Any other use will automatically invalidate all warranty and liability claims. Remain aware of safety and risks.

Setting up and installing the equipment

WARNING

- ☞ When **operating the pump as a compressor**, check that the system which you are going to pressurize is mechanically stable. Check that the maximum generated overpressure is compatible with the mechanical stability of the pressure vessel. Do not generate overpressure in vessels other than in those designed for that purpose. **Risk of bursting!**

Comply with **maximum permissible pressure** at the outlet (**58 psi (4 bar) absolute**). The pump has an overpressure safety relief device at the pressure adjustment device at the outlet (opening pressure: 58 psi (4 bar) absolute). Install an additional overpressure safety relief device in the pressure system, if necessary.

Note: Flexible elements will expand when pressurized.

- ☞ Especially when using the pump as vacuum pump provide a free and pressureless exhaust outlet to avoid damage to pump valves and risk of bursting.

Important information: Equipment marking (ATEX)

Only valid for products with ATEX marking. If the ATEX marking is shown on the rating plate of the respective product, VACUUBRAND GMBH + CO KG assures, that the device complies with the provisions of the directive 2014/34/EU. The applied harmonized standards are indicated in the EC Declaration of Conformity of the Machinery (see instructions for use).

VACUUBRAND equipment bearing the ATEX mark (see rating plate)

The classification according to ATEX is only valid for the inner part (wetted part, pumped gas or vapor) of the equipment. The equipment is not suitable for use in external, potentially explosive atmospheres (environment).

The overall category of the equipment depends on the connected components. If the connected components do not comply with the classification of the VACUUBRAND equipment, the specified category of the VACUUBRAND equipment is no longer valid.

Vacuum pumps and vacuum gauges in category 3 are intended for connection to equipment in which during normal operation explosive atmospheres caused by gases, vapors or mists normally don't occur; or, if they do occur, are likely to do so only infrequently and for a short period only. Equipment in this category ensures the requisite level of protection during normal operation.

The use of gas ballast or the operation of venting valves is only permitted if thereby explosive atmospheres normally don't occur in the interior of the equipment or, if they do occur, are likely to do so only infrequently and for a short period.

The pumps are marked with "X" (according to DIN EN ISO 80079-36:2016), i.e., restrictions of the operation conditions:

- The equipment is designated for a low degree of mechanical stress and has to be installed in a way so that it cannot be damaged from outside.

Pumping units have to be installed so that they are protected against shocks from the outside and against glass splinters in the event of breakage (implosion).

- The equipment is designated for an ambient and gas inlet temperature during operation of +10 to +40°C. Never exceed these ambient and gas inlet temperatures. If pumping / measuring gases which are not potentially explosive, extended gas inlet temperatures are permissible. See instructions for use, section “Gas inlet temperatures” or “Technical data”.

After any intervention at the equipment (e.g., repair / maintenance) the ultimate vacuum of the pump has to be checked. Only if the pump achieves its specified ultimate vacuum is the pump's leak rate low enough to ensure that no explosive atmospheres will occur in the interior of the equipment.

After any intervention at the vacuum sensor, the leak rate of the equipment has to be checked.



Attention: This manual is not available in all languages of the EU. The user must not operate the device if he does not understand this manual. In this case a technically correct translation of the complete manual has to be available. The manual must be completely read and understood before operation of the device. All specified measures must be applied, or else must be replaced by equivalent measures at the user's own risk.

Technical data

General technical data valid for all pumps

Permissible ambient temperature storage / operation	°F (°C)	14 to 140 / 50 to 104 (-10 to +60 / +10 to +40)
Permissible relative atmospheric moisture during operation (no condensation)	%	30 to 85
Maximum permissible installation altitude above mean sea level	ft (m)	6500 (2000)
No-load speed 50/60 Hz	rpm	1500 / 1800
Device fuse		slow blow fuse 6.3 A
Motor protection		thermal cutout, manual reset*
Overvoltage category		II
Degree of protection IEC 60529		IP 40
Degree of protection UL 50E		type 1
Pollution degree		2
A-weighted emission sound pressure level** (uncertainty K_{pA} : 3 dB(A))	dB(A)	45

* In case of supply voltage below 115 V, the lock of the cutout might be restricted.

** Measurement according to EN ISO 2151:2004 and EN ISO 3744:1995 at 230V/50Hz and ultimate vacuum with (optional) silencer at outlet.

Gas inlet temperatures

Operating condition	Inlet pressure	Permitted range of gas temperatures at inlet
Continuous operation	> 75 Torr (100 mbar) (high gas load)	➔ 50 °F to 104 °F (+10 °C to +40 °C)
Continuous operation	< 75 Torr (100 mbar) (low gas load)	➔ 32 °F to 140 °F* (0 °C to +60 °C*)
Short-time (< 5 minutes)	< 75 Torr (100 mbar) (low gas load)	➔ 14 °F to 176 °F* (-10 °C to +80 °C*)

* if pumping potentially explosive atmospheres: 50 °F to 104 °F (+10°C to +40°C)

We reserve the right for technical modification without prior notice!

Type		ME 4 NT ME 4S NT	MZ 2 NT	MZ 2S NT
ATEX approval if the ATEX marking is shown on the rating plate Inner part (pumped gases)		II 3/- G Ex h IIC T3 Gc X Internal Atm. only Tech.File: VAC-EX02		
Maximum pumping speed 50/60 Hz (ISO 21360)	cfm (m ³ /h)	2.4 / 2.6 (4.0 / 4.4)	1.3 / 1.4 (2.2 / 2.4)	1.2 / 1.4 (2.0 / 2.3)
Ultimate vacuum (absolute)	Torr (mbar)	52 (70) ME 4S NT: 56 (75)	5.2 (7)	5.2 (7)
Maximum permissible inlet pressure (absolute)	psi (bar)	16 (1.1)		
Maximum permissible outlet pressure (absolute)	psi (bar)	29 (2)		
Maximum pressure difference between inlet and outlet	psi (bar)	29 (2)		
Rated motor power	hp (kW)	0.24 (0.18)		
Maximum permissible range of supply voltage (±10%) Attention: Observe specifications of rating plate! Dual voltage motor		100-115 V~ 50/60 Hz, 120 V~ 60 Hz 230 V~ 50/60 Hz 100-115 V~ 50/60 Hz, 120 V 60 Hz / 200-230 V~ 50/60 Hz		
Maximum rated current at: 100-115 V~ 50/60 Hz, 120 V~ 60 Hz 200-230 V~ 50/60 Hz 230 V~ 50/60 Hz	A A A	3.4 1.8 1.8		
Inlet		hose nozzle for tubing I.D. 3/8" (hose nozzle DN 10 mm)		
Outlet		thread G1/4"		
Dimensions L x W x H approx.	in (mm)	9.7 x 9.4 x 7.8 (246 x 239 x 198)		
Weight approx.	lbs. (kg)	24.2 (11.0)		

Type		MZ 2D NT	ME 8 NT	ME 8S NT
ATEX approval if the ATEX marking is shown on the rating plate Inner part (pumped gases)		II 3/- G Ex h IIC T3 Gc X Internal Atm. only Tech.File: VAC-EX02		
Maximum pumping speed 50/60 Hz (ISO 21360)	cfm (m ³ /h)	1.4 / 1.5 (2.3 / 2.5)	4.3 / 4.8 (7.3 / 8.1)	4.2 / 4.6 (7.1 / 7.8)
Ultimate vacuum (absolute)	Torr (mbar)	3 (4)	52 (70)	60 (80)
Maximum permissible inlet pressure (absolute)	psi (bar)	16 (1.1)	16 (1.1)	
Maximum permissible outlet pressure (absolute)	psi (bar)	16 (1.1)	29 (2)	
Maximum pressure difference between inlet and outlet	psi (bar)	16 (1.1)	29 (2)	
Rated motor power	hp (kW)	0.24 (0.18)	0.34 (0.25)	
Maximum permissible range of supply voltage (±10%) Attention: Observe specifications of rating plate! Dual voltage motor		100-115 V~ 50/60 Hz, 120 V~ 60 Hz -	100 V~ 50/60 120 V~ 60 230 V~ 50/60 Hz	
Maximum rated current at:				
100 V~ 50/60 Hz	A	-	5.0	
120 V~ 60 Hz	A	-	4.0	
230 V~ 50/60 Hz	A	1.8	3.0	
100-115 V~ 50/60 Hz, 120 V~ 60 Hz	A	3.4	5.7	
200-230 V~ 50/60 Hz	A	1.8	3.0	
Inlet		small flange KF 16	hose nozzle for tubing I.D. 3/8" (hose nozzle DN 10 mm)	
Outlet		silencer / G1/4"	2x thread G1/4"	
Dimensions L x W x H approx.	in (mm)	9.7 x 9.5 x 7.8 (246 x 242 x 198)	12.9 x 9.4 x 7.8 (328 x 239 x 198)	
Weight approx.	lbs. (kg)	25.1 (11.4)	36.2 (16.4)	

Type		MD 4S NT	MD 4 NT	MV 2 NT
ATEX approval if the ATEX marking is shown on the rating plate Inner part (pumped gases)		II 3/- G Ex h IIC T3 Gc X Internal Atm. only Tech.File: VAC-EX02		
Maximum pumping speed 50/60 Hz (ISO 21360)	cfm (m ³ /h)	2.2 / 2.5 (3.8 / 4.3)		1.3 / 1.4 (2.2 / 2.4)
Ultimate vacuum (absolute)	Torr (mbar)	1.5 (2)	0.75 (1.0)	0.4 (0.5)
Maximum permissible inlet pressure (absolute)	psi (bar)	16 (1.1)		
Maximum permissible outlet pressure (absolute)	psi (bar)	16 (1.1)		
Maximum pressure difference between inlet and outlet	psi (bar)	16 (1.1)		
Rated motor power	hp (kW)	0.34 (0.25)		
Maximum permissible range of supply voltage (±10%) Attention: Observe specifications of rating plate! Dual voltage motor		100-115 V~ 50/60 Hz, 120 V~ 60 Hz 230 V~ 50/60 Hz 100-115 V~ 50/60 Hz, 120 V 60 Hz / 200-230 V~ 50/60 Hz		
Maximum rated current at: 100-115 V~ 50/60 Hz, 120 V~ 60 Hz 200-230 V~ 50/60 Hz 230 V~ 50/60 Hz	A A A	5.7 3.0 3.0		
Inlet		hose nozzle for tubing I.D. 3/8" (hose nozzle DN 10 mm)	small flange KF 16	
Outlet		hose nozzle for tubing I.D. 3/8" (hose nozzle DN 10 mm)	silencer / G1/4"	
Dimensions L x W x H approx.	in (mm)	12.9 x 9.4 x 7.8 (328 x 239 x 198)		
Weight approx.	lbs. (kg)	36.2 (16.4)		

Type		ME 4R NT	ME 2 NT
ATEX approval if the ATEX marking is shown on the rating plate Inner part (pumped gases)		-	II 3/- G Ex h IIC T3 Gc X Internal Atm. only Tech.File: VAC-EX02
Maximum pumping speed 50/60 Hz (ISO 21360)	cfm (m ³ /h)	2.2 / 2.5 (3.8 / 4.2)	1.2 / 1.3 (2.0 / 2.2)
Ultimate vacuum (absolute)	Torr (mbar)	75 (100)	52 (70)
Maximum permissible inlet pressure (absolute)	psi (bar)	16 (1.1)	
Maximum permissible outlet pressure (absolute)	psi (bar)	58 (4)	29 (2)
Maximum permissible outlet pressure (manometer reading)	psi (bar)	44 (3)	-
Maximum pressure difference between inlet and outlet	psi (bar)	58 (4)	29 (2)
Rated motor power	hp (kW)	0.24 (0.18)	
Maximum permissible range of supply voltage (±10%) Attention: Observe specifications of rating plate!		100-115 V~ 50/60 Hz, 120 V 60 Hz 230 V~ 50/60 Hz	
Maximum rated current at: 100-115 V~ 50/60 Hz, 120 V~ 60 Hz 230 V~ 50/60 Hz	A A	3.4 1.8	
Inlet		hose nozzle for tubing I.D. 3/8" (hose nozzle DN 10 mm)	
Outlet		hose nozzle for tubing I.D. 3/8" (hose nozzle DN 10 mm)	thread G1/4"
Dimensions L x W x H approx.	in (mm)	10.0 x 10.6 x 11.4 (254 x 268 x 290)	9.7 x 8.3 x 7.8 (246 x 211 x 198)
Weight approx.	lbs. (kg)	25.4 (11.5)	22.5 (10.2)

Type	MD 4CRL NT	
ATEX approval if the ATEX marking is shown on the rating plate Inner part (pumped gases)	II 3/- G Ex h IIC T3 Gc X Internal Atm. only Tech.File: VAC-EX02	
Maximum pumping speed 50/60 Hz (ISO 21360)	cfm (m ³ /h)	2.0 / 2.2 (3.4 / 3.8)
Ultimate vacuum (absolute)	Torr (mbar)	1.1 (1.5)
Maximum permissible inlet pressure (absolute)	psi (bar)	16 (1.1)
Maximum permissible outlet pressure (absolute)	psi (bar)	16 (1.1)
Maximum pressure difference between inlet and outlet	psi (bar)	16 (1.1)
Leak rate (integral)	Torr*cfm (mbar*l/s)	0.0016 (0.001)
Rated motor power	hp (kW)	0.34 (0.25)
Maximum permissible range of supply voltage (±10%) Attention: Observe specifications of rating plate!	100-115 V~ 50/60 Hz, 120 V 60 Hz / 200-230 V~ 50/60 Hz	
Maximum rated current at: 100-115 V~ 50/60 Hz, 120 V~ 60 Hz 200-230 V~ 50/60 Hz	A A	5.7 3.0
Inlet	small flange KF 16	
Outlet	small flange KF 16	
Dimensions L x W x H approx.	in (mm)	12.9 x 9.6 x 7.8 (328 x 243 x 198)
Weight approx.	lbs. (kg)	43.7 (19.8)

Wetted parts

Components	Wetted materials
Housing cover	aluminum alloy (AlMgSi0.5 or AlSi12)
Head cover	aluminum alloy (AlSi12)
Diaphragm clamping disc	aluminum alloy (AlSi12)
Diaphragm clamping disc (ME 4S NT / MZ 2S NT / ME 8S NT / MD 4S NT)	ETFE glass fiber reinforced
Diaphragm	FPM
Diaphragm (ME 4S NT / MZ 2S NT / ME 8S NT / MD 4S NT / ME 4R NT)	PTFE
Valves	FPM
Valves (MZ 2D NT)	FPM / PTFE
Valves (ME 4S NT / MZ 2S NT / ME 8S NT / MD 4S NT)	FFKM
Valves (ME 4R NT)	PTFE
O-rings	FPM
Connection tube	aluminum alloy (AlMgSi0.5)
Small flange	stainless steel
Hose nozzle	PBT
Hose nozzle (ME 4 NT / ME 4S NT)	stainless steel
Silencer (MD 4 NT / MV 2 NT / MZ 2D NT)	aluminum alloy / silicone
Silencer, optional (ME 2 NT / ME 4(S) NT / ME 8(S) NT / MZ 2(S) NT)	PA / PE / aluminium
Fittings (ME 4 NT / ME 4R NT / ME 4S NT / MZ 2 NT / MZ 2S NT / MZ 2D NT)	aluminum, anodized
Tubing (ME 4(R) NT / MZ 2 NT / MZ 2D NT)	PE
Tubing (ME 4S NT / MZ 2S NT)	PTFE
Seal rings (ME 4 NT / ME 4R NT / ME 4S NT / MZ 2 NT / MZ 2S NT / MZ 2D NT)	PVC
MD 4CRL NT	
Housing cover	stainless steel
Head cover	ETFE carbon fiber reinforced
Diaphragm clamping disc	ETFE carbon fiber reinforced
Diaphragm	PTFE

Components	Wetted materials
Valves	FFKM
Connection tube	PTFE
MD 4CRL NT	
Fittings	stainless steel
Seal rings	FPM
Vacuum / pressure adjustment device (ME 4R NT)	
O-ring	NBR
Valve block	aluminum alloy
Seal ring at manometer	copper
Hollow bolt, dispensing screw	stainless steel
Overpressure safety relief device	FPM

We reserve the right for technical modification without prior notice!

Abbreviations

ETFE: Ethylene/Tetrafluoroethylene

FFKM: Perfluoro elastomer

FPM: Fluoroelastomer

NBR: Nitrile butadiene rubber

PA: Polyamide

PBT: Polybutylene terephthalate

PE: Polyethylene

PTFE: Polytetrafluoroethylene

PVC: Polyvinyl chloride

Pump parts

Position	Component
1	Inlet
2	Outlet
3	ON/OFF switch
4	Power connection
5	Handle
6	Pump rating plate
7	Fan
8	Inlet with vacuum adjustment device
9	Outlet with pressure adjustment device
10	Dispensing screw
11	Overpressure manometer
12	Vacuometer
13	Overpressure safety relief device
14	Voltage selection switch

We reserve the right for technical modification without prior notice!

Power connection (all pump designs)

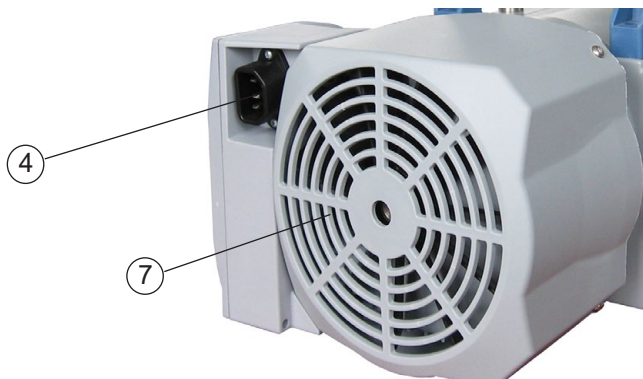

ME 2 NT

(fig.: with optional silencer)



ME 4 NT / ME 4S NT

(fig.: ME 4 NT with optional silencer)



ME 4R NT

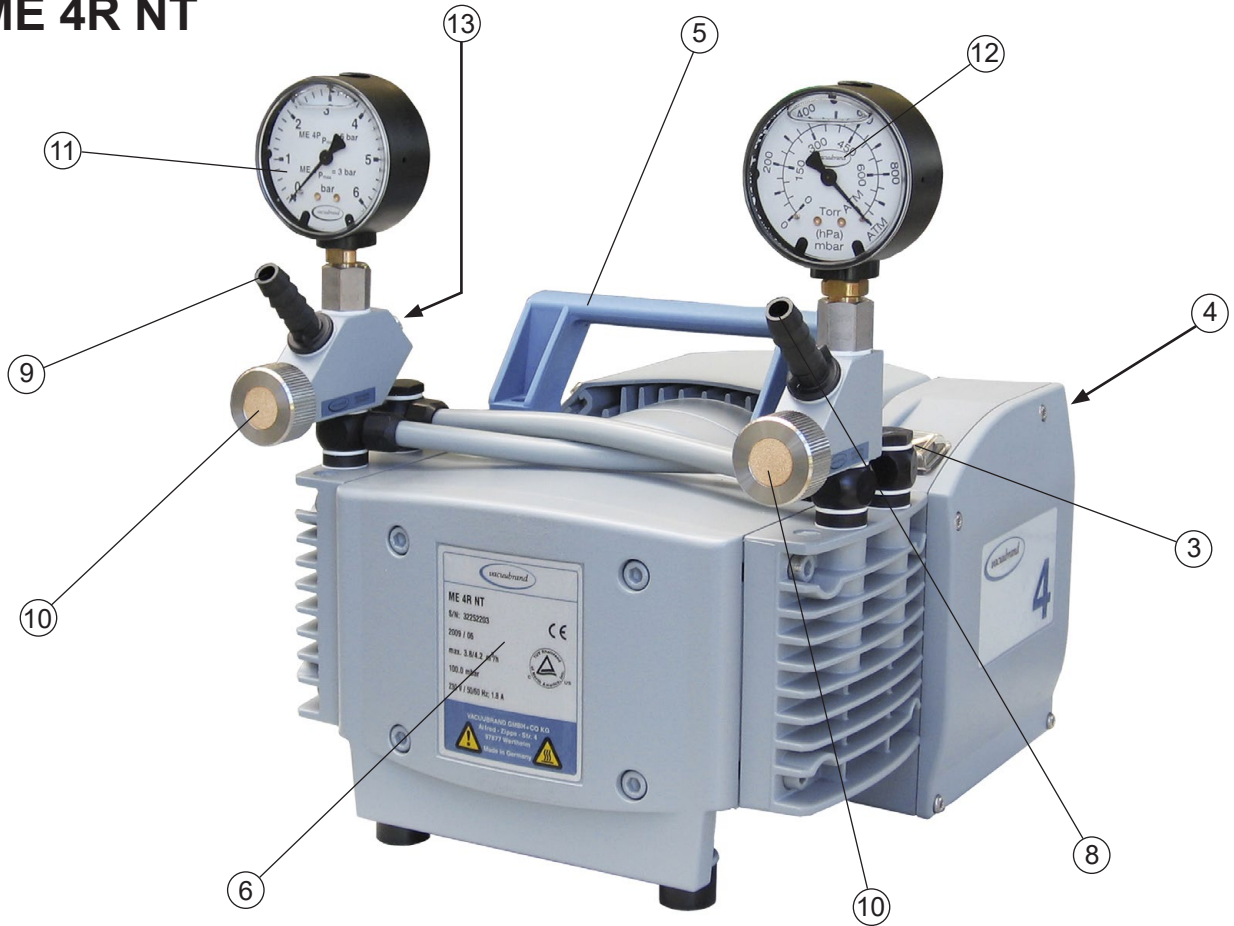

MZ 2 NT / MZ 2S NT

(fig.: MZ 2 NT with optional silencer)



MZ 2D NT



ME 8 NT / ME 8S NT (fig.: with optional silencers)



MD 4 NT / MV 2 NT

(fig.: MD 4 NT)

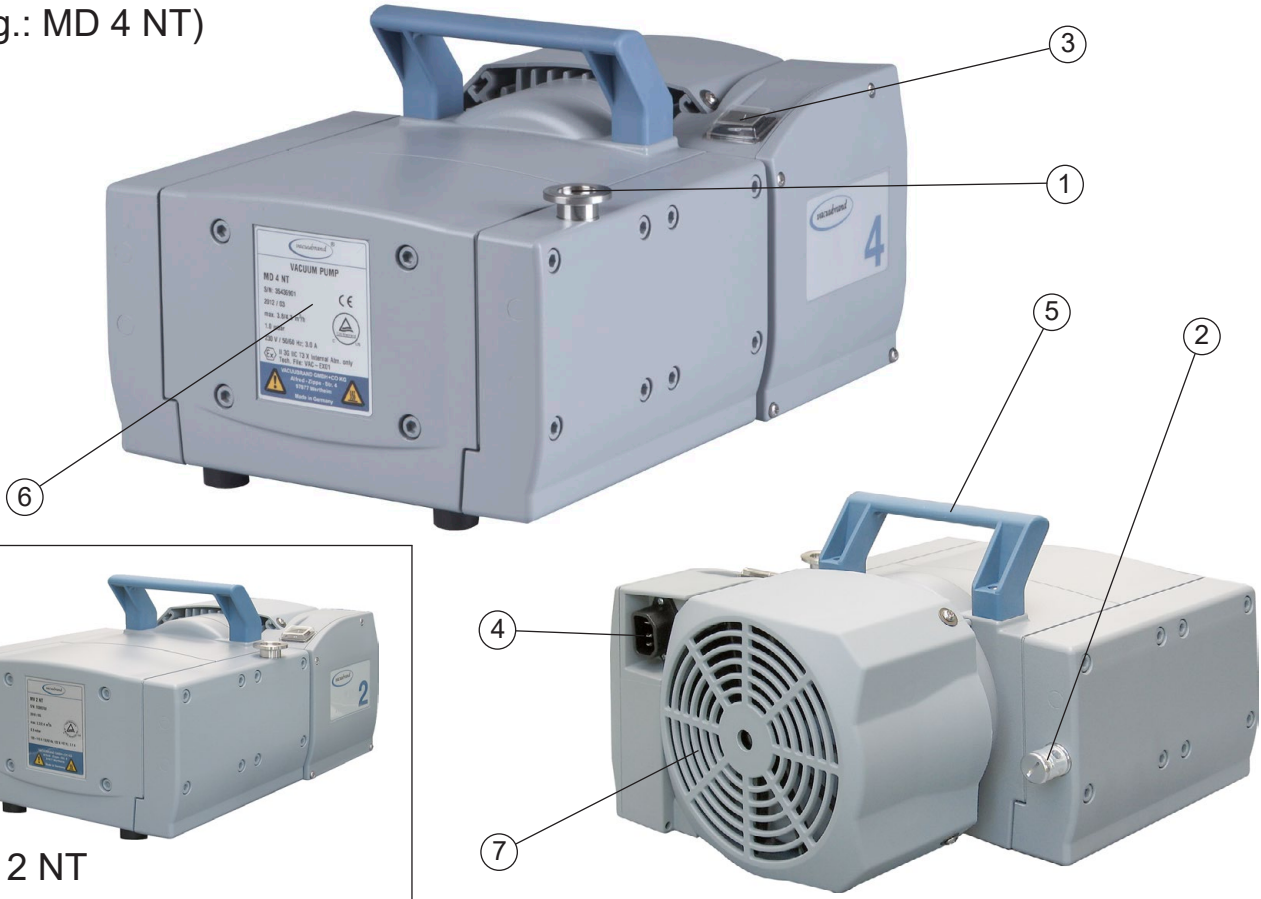

MD 4S NT

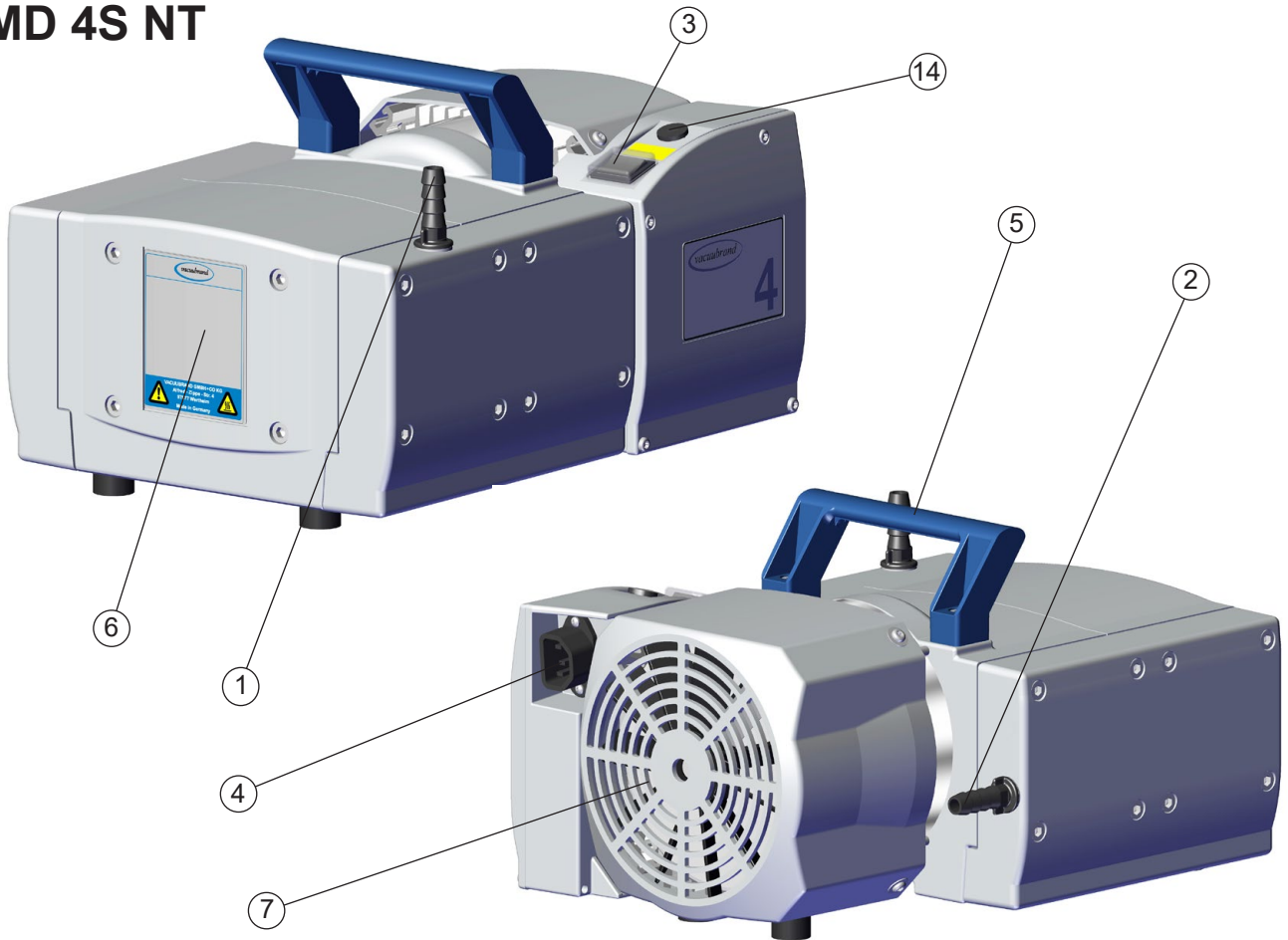

MD 4CRL NT



Only pumps with dual-voltage motor:



Voltage selection switch:

1. Disconnect the electrical power cord.
2. Use a screw driver to adjust the **voltage selection switch** at the terminal box of the pump to the supply voltage:

"115/120" corresponds to 100-120 V and

"230/240" corresponds to 200-230 V.

CAUTION

- Check that the voltage selection switch is positioned correctly.
Note: If the pump is switched on with wrong voltage selection, the motor may be damaged!
- Check every time before starting the pump.
- **Change the selection at the voltage selection switch only if the pump is unplugged from the power source.**

Use and operation

Installation

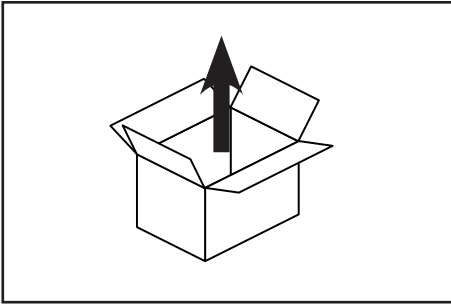

Remove the product from its packing-box.

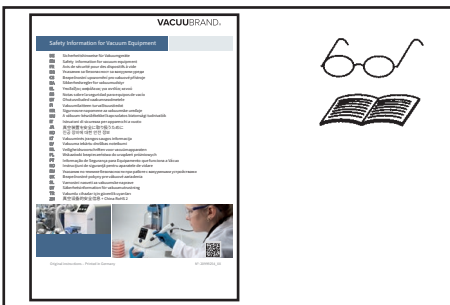

Read the document "Safety information for vacuum equipment" and observe the instructions contained therein!



Put the pump in place.

Keep a minimum distance of 2 in (5 cm) between the cooling fan and surrounding items (e.g., housing, walls, etc.), or else install an external automatic ventilation system. The mains plug is a disconnecting device to separate the pump from the supply voltage.

Ensure that the mains plug is easily accessible at all times to allow the separation of the device from the power supply.

WARNING

☞ Make sure ventilation is adequate, especially if the pump is installed in an enclosure, or if the ambient temperature is elevated. Provide external ventilation, if necessary.

ME 2 NT / ME 4 NT / ME 8 NT / MZ 2 NT:

Prior to switch-on, remove the grip plug at the outlet and assemble the enclosed silencer or the enclosed hose nozzle for tubing I.D. 3/8" (10 mm) at the outlet (see section "Connecting the outlet", pg. 43).

ME 4S NT / ME 8S NT / MZ 2S NT:

Prior to switch-on, remove the grip plug at the outlet and assemble the enclosed silencer or a hose nozzle for tubing I.D. 3/8" (10 mm) (see "Accessories", pg. 53) at the outlet (see section "Connecting the outlet", pg. 43).

Vacuum connection (inlet)

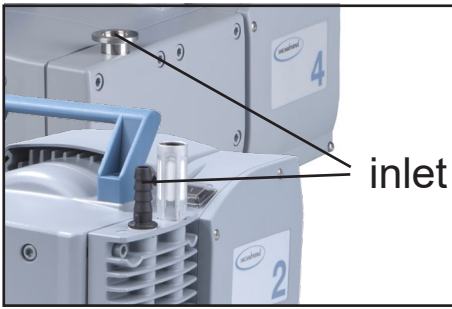

Inlet:

Hose nozzle for tubing I.D. 3/8" (10 mm) or small flange KF DN 16.

Connect the vacuum line (e.g., vacuum hose I.D. 3/8" (DN 10 mm) at the inlet of the pump.

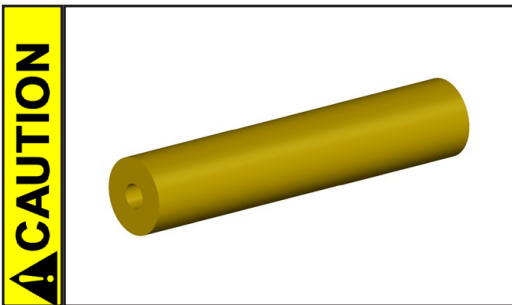

- Reduce the transmission of vibration. Prevent mechanical load due to rigid pipelines. Insert elastic hoses or flexible elements as couplings between the pump and rigid pipes.

Note: Flexible elements will compress or flatten when evacuated if not designed for use under vacuum.

- Hose connections at the pump inlet must always be gas tight and secured against loosening, for example, with a hose clamp.

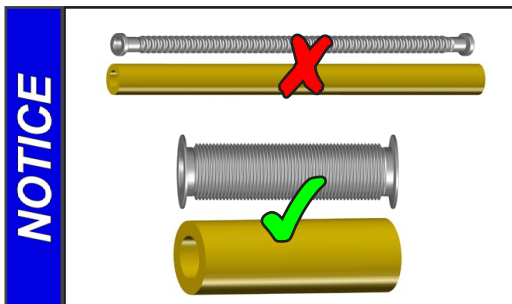

Use connecting hoses with large diameter and keep them as short as possible to avoid flow losses. Locate the pump as closely as possible to the application.

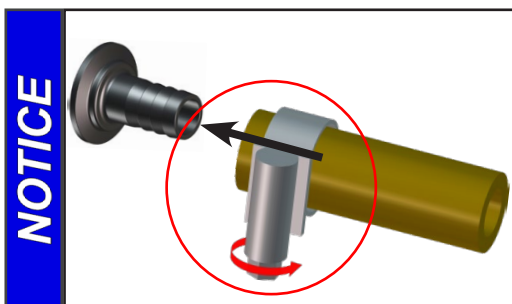

Secure hose connections at the pump appropriately, e.g., with hose clamps, to protect against accidental detachment.



☞ Particles and dust must not be aspirated. If necessary, you must install appropriate filters. You must ensure their suitability concerning gas flow, chemical resistance and resistance to clogging prior to use.

CAUTION

- A power failure may cause accidental ventilation of the pump. If this constitutes a potential source of danger, take appropriate safety measures.

NOTICE

When assembling, ensure **vacuum-tightness**. After assembly, check the whole system for leaks.

Use a suitable valve to isolate the pump from the vacuum application. This is to allow the pump to warm up before pumping condensable vapors and to clean the pump after use before it is switched off.

Connecting the outlet**ME 2 NT / ME 4 NT / ME 8 NT / MZ 2 NT:**

Outlet via thread G 1/4". Remove the grip plug at the outlet. Assemble the enclosed silencer or the enclosed hose nozzle for tubing I.D. 3/8" (10 mm) at the outlet.

ME 4S NT / ME 8S NT / MZ 2S NT:

Outlet via thread G 1/4". Remove the grip plug at the outlet. Assemble the enclosed silencer or a hose nozzle for tubing I.D. 3/8" (10 mm) (see "Accessories", pg. 53) at the outlet.

MD 4 NT / MV 2 NT / MZ 2D NT:

Outlet via silencer.

MD 4S NT / ME 4R NT:

Outlet via hose nozzle for tubing I.D. 3/8" (10 mm).

MD 4CRL NT:

Outlet via small flange KF DN 16.

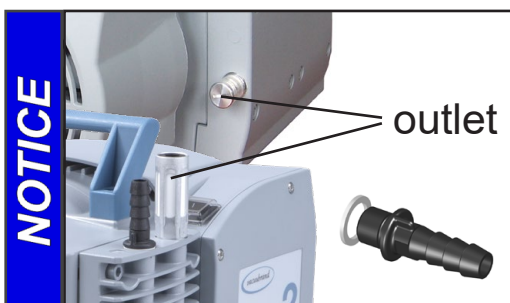

Attention: Use the (optional) silencer only in case of low gas throughput. Check the silencer regularly for permeability! In case, install a hose nozzle with sealing ring instead (see "Accessories", pg. 53).

Connecting an exhaust line at the outlet of a pump with silencer at the outlet:

Unscrew the silencer and install a hose nozzle DN 10 mm with sealing ring (thread G1/4").

! DANGER

➔ If dangerous or polluting fluids could be released at the outlet, install an appropriate system to catch and dispose of those fluids.

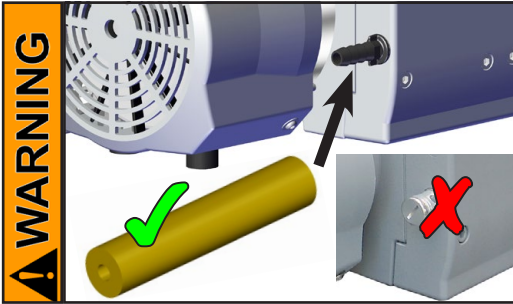

☞ Connect a gas-tight exhaust line at the pump outlet nozzle and secure against loosening, for example, with a hose clamp. Always vent exhaust gases appropriately (e.g., into a fume hood). In case, replace silencer with hose nozzle, see above).

☞ MD 4CRL NT: Connect a gas-tight exhaust line at the pump outlet (small flange KF DN 16).

☞ Never block the gas outlet. The exhaust line must always be free of obstructions (no back pressure) to ensure an unimpeded discharge of gas. The cross-section of the outlet tubing must be at least the size of the pump's exhaust connection.

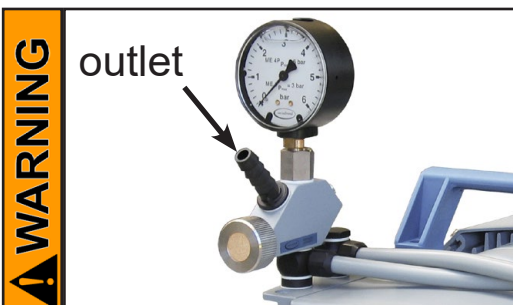

ME 4R NT:

☞ When **operating the pump as a compressor**, check that the system which you are going to pressurize is mechanically stable. Check that the maximum generated overpressure is compatible with the mechanical stability of the pressure vessel. Do not generate overpressure in vessels other than in those designed for that purpose. **Risk of bursting!**

Install an additional overpressure safety relief device in the pressure system, if necessary.

☞ Especially when using the pump as vacuum pump provide a free and pressureless exhaust outlet to avoid damage to pump valves and risk of bursting.

CAUTION

- Reduce the transmission of vibration. Prevent mechanical load due to rigid pipelines. Insert elastic hoses or flexible elements as couplings between the pump and rigid pipes.
- **ME 2 NT / ME 4(S) NT / ME 8(S) NT / MZ 2(S) NT:** The surface temperature of the optional silencer might be elevated in case of high gas throughput. In case of high gas throughput, replace the optional silencer with a hose nozzle.

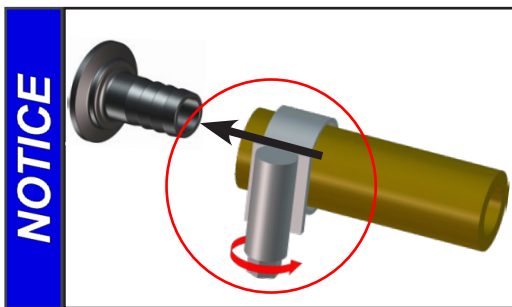

NOTICE

Secure hose connections at the pump appropriately, e.g., with hose clamps, to protect against accidental detachment.

To reduce pump noise emanating from the pump exhaust port (ME 4R NT / MD 4S NT), connect an exhaust hose or use a silencer (see “Accessories”, pg. 53).

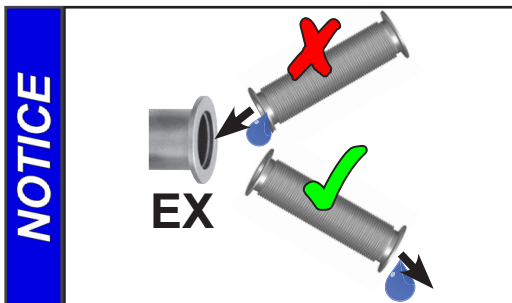

NOTICE

Always install outlet tubing descending from the pump or provide other measures to avoid backflow of condensate towards the pump.

Notes prior to the use of the manometers (ME 4R NT)

The manometers are filled with glycerin. The overpressure manometer indicates the overpressure relative to the atmospheric pressure at the place of operation. The vacuum meter indicates the underpressure relative to the atmospheric pressure at the place of operation but with absolute scaling.

- ☞ Install the pump in the room of operation.
- ☞ **Vent the reference chambers** prior to use. Else, not venting the manometers may lead to a systematic measuring error.

There are different types of manometers. To vent the reference chamber check which types of manometers are installed at the pump and proceed according to the given instructions:

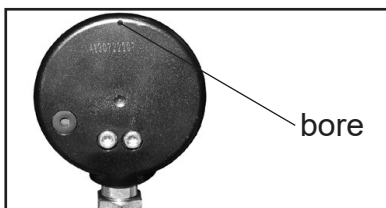

A: Manometer with bore at the rear side

Pierce the hole at the rear side of the manometer. Some outflow of liquid is normal.

- ☞ Do not tilt pump during transport.



B: Manometer with pin

Lift the pin to vent the manometer. Do not remove the pin completely! Close after venting.

- ☞ Repeat if necessary until the dial shows ATM with the measuring connection at atmospheric pressure.

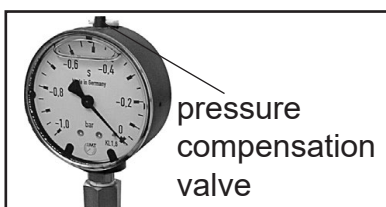

C: Manometer with pressure compensation valve

Vent the manometer using the pressure compensation valve. Close the valve after ventilation.

- ☞ Repeat if necessary until dial shows zero with measuring connection at atmospheric pressure.



D: Manometer without bore, pin or pressure compensation valve

Do **not** vent the reference chamber of this manometer!

Electrical connection

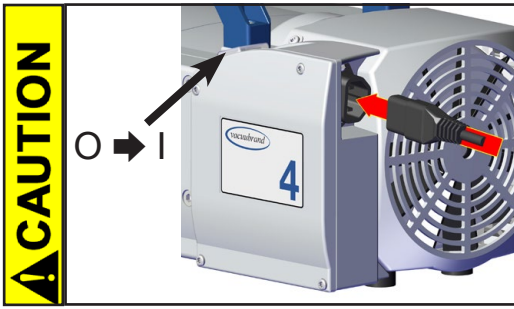

Plug in the power cord.

- Check the power source and the pump's rating plate to be sure that the power source and the equipment match in voltage, phase, and frequency.

Switch the pump on.



Pump with dual-voltage motor:

- Check the power source and the pump's rating plate to be sure that the power source and the equipment match in voltage, phase, and frequency.
- Check that the voltage selection switch is positioned correctly. Check every time before starting the pump. **Note:** If the pump is switched on with wrong voltage selection, the motor may be damaged!



Changing the selection at the voltage selection switch:

- Change the selection at the voltage selection switch only, if the pump is unplugged from the power source.

1. **Disconnect the electrical power cord.**
2. Use a screw driver to adjust the voltage selection switch to the supply voltage:

"115/120" corresponds to 100-120 V and
"230/240" corresponds to 200-230 V.

During operation



➔ Vent and dispose of **potentially dangerous gases or vapors** at the outlet of the pump appropriately.



☞ Due to the high compression ratio, the pump might generate overpressure at the outlet. Check pressure compatibility with system components (e.g., exhaust tubing or exhaust valve) at the outlet. Ensure that the pump outlet is neither blocked nor restricted.



☞ **Maximum ambient temperature:** 104 °F (40 °C)

Check the maximum temperatures, if installing the pump in a cabinet or a housing. Make sure ventilation is adequate, especially if the ambient temperature is elevated.

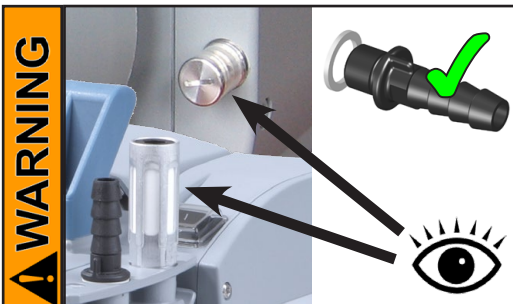

☞ **Operation with (optional) silencer at the outlet:** Operating the pump at a high inlet pressure or pumping dusty gases for a long time may cause clogging of the (optional) silencer. Check the silencer regularly and replace if necessary, or install a hose nozzle with sealing ring instead (see “Accessories”, pg. 53).

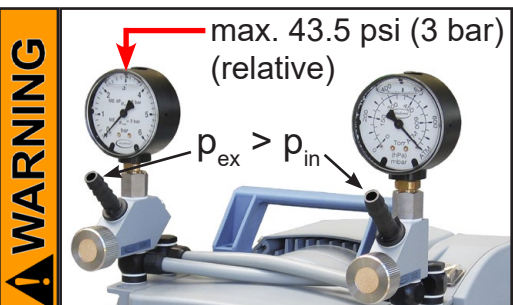

ME 4R NT:

☞ In case of continuous operation with inlet pressures above atmospheric pressure: the inlet pressure (p_{in}) must not exceed the outlet pressure (p_{ex}). **Maximum permissible outlet pressure:** 58 psi (4 bar) absolute.

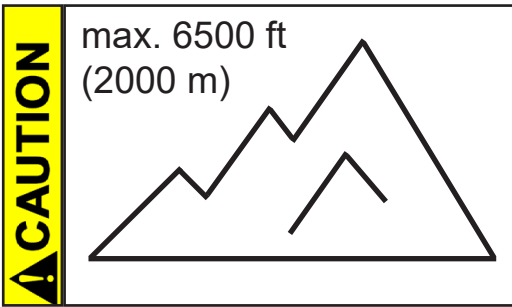

- If the pump is installed at an altitude of more than 6500 ft (2000 m) above mean sea level, check compatibility with applicable safety requirements, and adopt suitable measures. There is a risk of the motor overheating due to insufficient cooling.

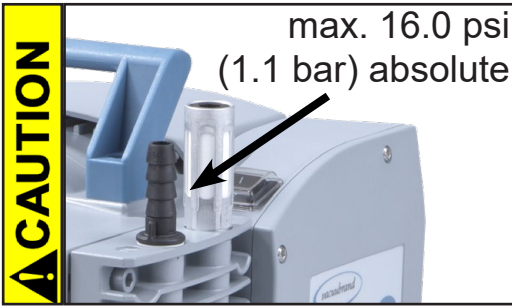

- Check compatibility with the **maximally permitted pressure** at inlet and at outlet and the **maximum pressure difference** between inlet and outlet ports.

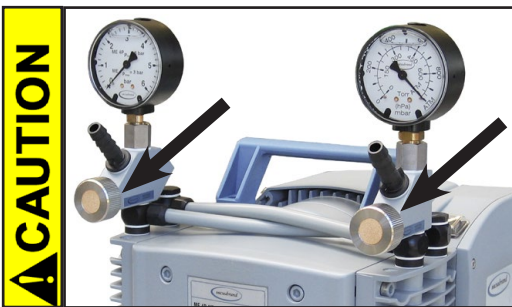

ME 4R NT:

- **Note:** There are no stops at the end of the dispensing screws' threads! Do not completely unscrew the dispensing screws!

NOTICE

Do not start the pump if the **pressure difference between inlet and outlet ports exceeds max. 16.0 psi (1.1 bar)**. Attempts to start the pump at higher pressure difference may cause stalling and damage of the motor.

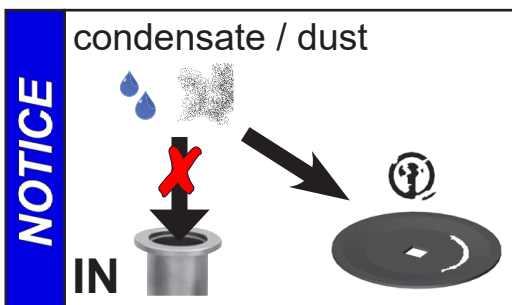

Prevent internal condensation, transfer of liquids or dust. The diaphragms and valves will be damaged, if liquids are pumped in significant amounts.

Check the pump regularly for external soiling and deposits. Clean the pump if necessary to avoid an increase of the pump's operating temperature.

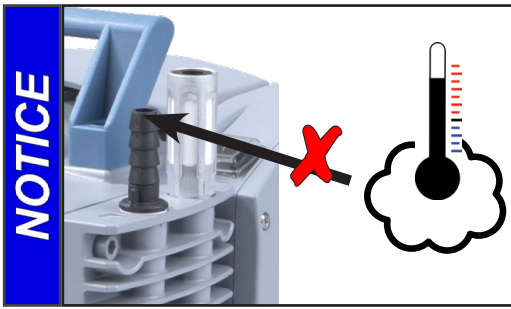

Avoid overheating (e.g., due to hot process gases). Maximum permissible temperature range: see “Gas inlet temperatures”, pg. 26.

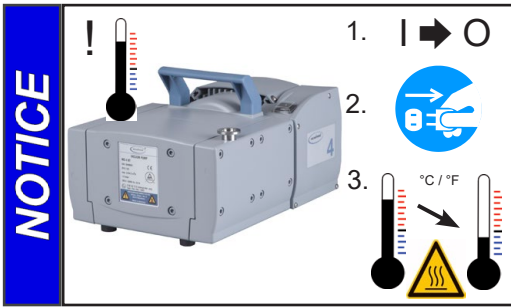

In case of overload, the motor is shut down by a **self-hold thermal cutout** in the winding. **Note:** Only manual reset is possible. Switch off the pump and disconnect the electrical power cord. Identify and eliminate the cause of failure. Allow the pump to cool down sufficiently before restart.

CAUTION

- **Note:** In case of **supply voltage below 115 V**, the lock of the cutout might be impaired and the pump may restart on its own after sufficient cooling down. Take appropriate precautions, if an automatic restart of the pump may lead to a dangerous situation (e.g., switch off the pump and disconnect from the power source).

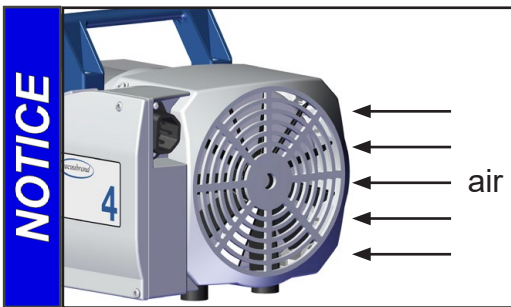

Make sure the fan's air supply is adequate. Check fan regularly for dust/dirt. Clean fan guard grill if necessary to avoid a reduction of ventilation.



A warm up period (approximately 15 min.) is required to ensure that the rated ultimate vacuum and pumping speed are attained.

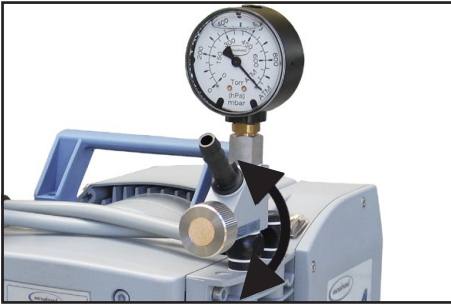

ME 4R NT:

Use the vacuum adjustment device at the inlet port of the pump to **control the vacuum** in the system. Turning the dispensing screw controls the amount of gases pumped from the vacuum system:

- Turning the dispensing screw counterclockwise: vacuum is decreased (higher pressure) (Intake of additional bleed air via the dispensing screw.)
- Turning the dispensing screw clockwise: vacuum is increased (lower pressure)

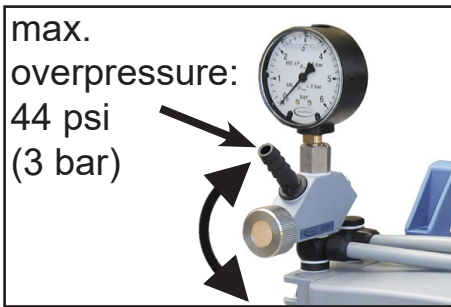

Use the pressure adjustment device at the outlet port of the pump to control the **overpressure** accordingly:

- Turning the dispensing screw counterclockwise: pressure is decreased (Pump blows off via dispensing screw.)
- Turning the dispensing screw clockwise: pressure is increased

WARNING

Note: Maximum permissible overpressure at the outlet side of the ME 4R NT pump: 44 psi (3 bar)!

Shutdown & storage

The pump can be switched off under vacuum.

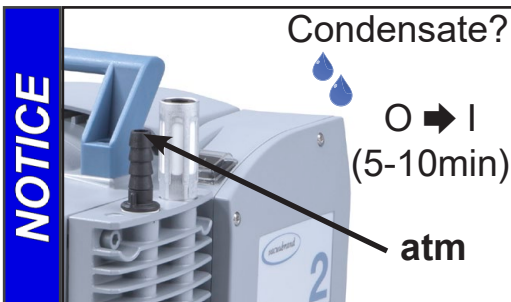

Short-term:

- Has the pump been exposed to condensate?
Allow the pump to continue to run at atmospheric pressure for a few minutes.
- Has the pump been exposed to media which may damage the pump materials or form **deposits**?
Check and clean pump heads if necessary.

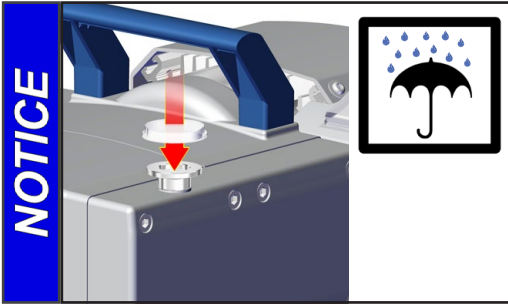

Long-term:

- Take measures as described above regarding short-term shutdown.
- Separate the pump from the application.
- Close inlet and outlet ports (e.g., with transport caps).
- Store the pump under dry conditions.

Accessories



Vacuum gauge DVR 2pro**20682906**

Vacuum hose (caoutchouc) I.D. 3/8" (10 mm ID)	20686002
Antistatic PTFE tubing KF DN 16 (500 mm).....	20686030
Antistatic PTFE tubing KF DN 16 (1000 mm).....	20686031
Tubing, stainless steel KF DN 16 (500 mm).....	20673316
Tubing, stainless steel KF DN 16 (1000 mm).....	20673336
Adapter small flange KF DN 16 to hose nozzle 1/2"	20636004
Adapter hose nozzle 3/8" (DN 10mm) to hose nozzle 1/2"	20636002
VACUU•LAN® Mini-Network with three VCL 01 modules	22614455
Vacuum adjustment device with manometer	20696840
Hose nozzle for tubing I.D. 3/8" (DN 10 mm) internal thread G 1/8", stainless steel	20639758
Sealing ring for hose nozzle 639758	20639729
Silencer for hose nozzle 3/8" (DN 10 mm)	20636588

Attention: Dust-laden gases, deposits and condensed solvent vapor can restrict air flow out the silencer. The resultant back pressure can lead to damage of pump bearings, diaphragms, and valves. Under those conditions, a silencer must not be used.



Check valve (flapper valve).....**20639683**
 (Simultaneous operation of two systems at different pressure levels, stainless steel/FFKM, leak rate < 1.6*10⁻³ Torr*cfm for pressure differences > 375 Torr (500 mbar))

For additional accessories such as vacuum valves, small-flange components, vacuum gauges or vacuum controllers refer to www.vacuubrand.com

Troubleshooting

Fault	Possible cause	Remedy
<input type="checkbox"/> Pump does not start or stops immediately.	<ul style="list-style-type: none"> ➔ Electrical power cord not plugged in, electrical supply failure? ➔ Device fuse blown? ➔ Overpressure in outlet line or in the system (at outlet side)? ➔ Motor overloaded? 	<ul style="list-style-type: none"> ✓ Plug in power cord. Check fuse. ✓ Identify cause of failure. Replace device fuse. ✓ Remove blockage in line, open valve, or reduce overpressure in the system (pressure adjustment device ME 4R NT). ✓ Allow motor to cool down, identify and eliminate cause of failure. Manual reset is necessary. Switch off pump or unplug.
<input type="checkbox"/> Pump does not achieve its ultimate vacuum or usual pumping speed.	<ul style="list-style-type: none"> ➔ Centring ring at small flange connection not correctly positioned, or leak in the pipeline or vacuum system? ➔ Vacuum adjustment device open (ME 4R NT)? ➔ Long, narrow vacuum line? ➔ Pump has been exposed to condensate? ➔ Deposits have been formed inside the pump? ➔ Diaphragms or valves damaged? ➔ Outgassing substances or vapor generated in the process? 	<ul style="list-style-type: none"> ✓ Check pump directly - connect vacuum gauge directly at pump inlet - then check connection, pipeline and vacuum system if necessary. ✓ Close vacuum adjustment device. ✓ Use lines with larger diameter, length as short as possible. ✓ Allow pump to run for some minutes with atmospheric pressure at the inlet to purge. ✓ Clean and inspect the pump heads. ✓ Replace diaphragms and/or valves. ✓ Check process parameters.

Fault	Possible cause	Remedy
<input type="checkbox"/> Pump too noisy.	<ul style="list-style-type: none"> ➔ Atmospheric or high pressure at the pump inlet? ➔ Diaphragm crack or diaphragm clamping disc loose? ➔ Other than above mentioned causes? 	<ul style="list-style-type: none"> ✓ Connect hose or silencer to pump outlet. Be careful not to cause outlet over-pressure, especially with condensable vapors. ✓ Perform maintenance. ✓ Contact local distributor.
<input type="checkbox"/> Pump seized.		<ul style="list-style-type: none"> ✓ Contact local distributor.

➔ A service manual with exploded view drawings, spare parts list and directions for repair is available on request.

👉 The service manual is intended for trained service people only.

Service kit for ME 2 NT.....	20696877
Service kit for ME 4 NT / MZ 2 NT	20696860
Service kit for MD 4 NT / MV 2 NT	20696861
Service kit for ME 8 NT	20696862
Service kit for MZ 2D NT	20696863
Service kit for ME 4S NT / MZ 2S NT	20696868
ME 8SNT/MD 4S NT	2x 20696868
Service kit for ME 4R NT	20696859
Service kit for MD 4CRL NT	20696870
Diaphragm key (width 66 mm)	20636554

Replacing diaphragms and valves

☞ Please read section "Replacing diaphragms and valves" completely before starting maintenance.

The pictures may show other versions of pumps. This does not change the method of replacing diaphragms and valves.

! DANGER

➔ Never operate the pump if covers or other parts of the pump are disassembled.



➔ Before starting maintenance, **disconnect the electrical power cord. Wait five seconds** after isolating the equipment from AC power to allow the capacitors to discharge.

➔ Ensure that the pump cannot be operated accidentally.

➔ **Note:** The pump might be contaminated with the process chemicals that have been pumped during operation. Ensure that the pump is decontaminated before maintenance.

➔ Avoid the release of pollutants.

! WARNING

☞ **Never operate a defective or damaged pump.**

☞ Check every motor capacitor regularly by measuring its capacity and estimating its service life. Replace old capacitors early enough to prevent a failure. The capacitors must be replaced by a trained electrician.



☞ Take adequate precautions to protect people from the effects of dangerous substances that may have contaminated the pump and may be released upon disassembly. Ensure that the maintenance technician is familiar with the safety procedures which relate to the products processed by the pumping system.

Use appropriate protective clothing, safety goggles and protective gloves.

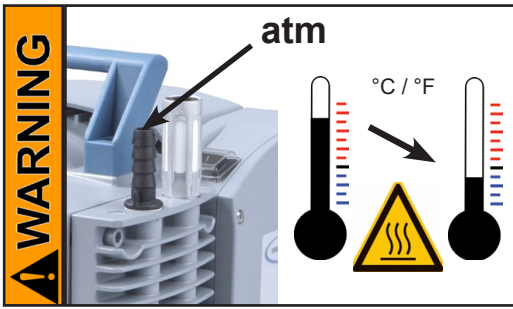

- ☞ Allow sufficient cooling of the pump before starting maintenance.
- ☞ **Vent the pump and isolate it from the vacuum system before you start maintenance.**

NOTICE

Ensure that maintenance is done only by suitably trained and supervised technicians.

The valves and diaphragms as well as the motor capacitors are wear parts. If the rated ultimate vacuum is no longer achieved or in case of increased noise level, the pump interior, the diaphragms and the valves must be cleaned and the diaphragms and valves must be checked for cracks or other damage.

All bearings are encapsulated and are filled with long-life lubricant. Under normal operating conditions, the drive system is maintenance free.

In demanding circumstances, it may be efficient to check and clean the pump heads on a regular basis. In normal use, the lifetime of the diaphragms and valves is typically 15,000 operating hours.

- Prevent internal condensation, transfer of liquids or dust. The diaphragms and valves will be damaged if liquid is pumped in significant amount.
- Carry out maintenance frequently if the pump is exposed to corrosive media or in case of deposits.
- Regular maintenance will improve the lifetime of the pump and also protect both users and the environment.

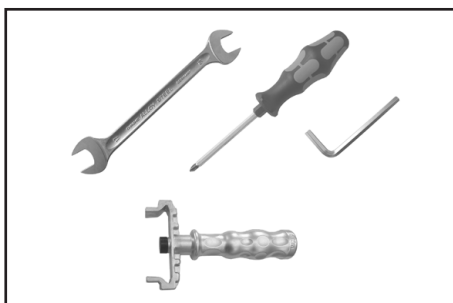

Tools required (metric):

- Phillips screwdriver size 2 (MZ 2D NT) ⊕
- 2 open end wrenches width 17 / 20 ⊖
(ME 4(R) NT, MZ 2(D, S) NT, MD 4CRL NT)
- 5 mm wide Allen key ⊖
- Diaphragm key width 66 mm

Checking diaphragms and valves (except MZ 2D NT)

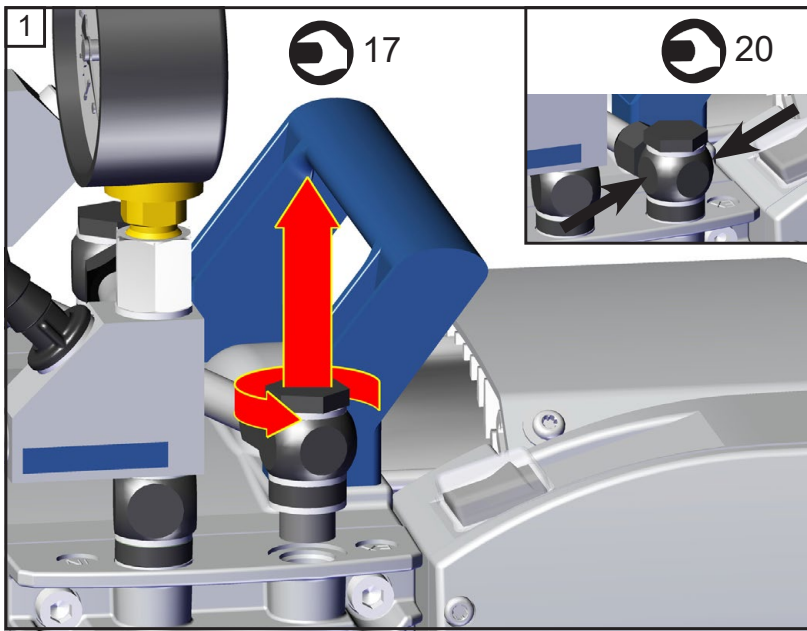

ME 4R NT

17 mm

20 mm

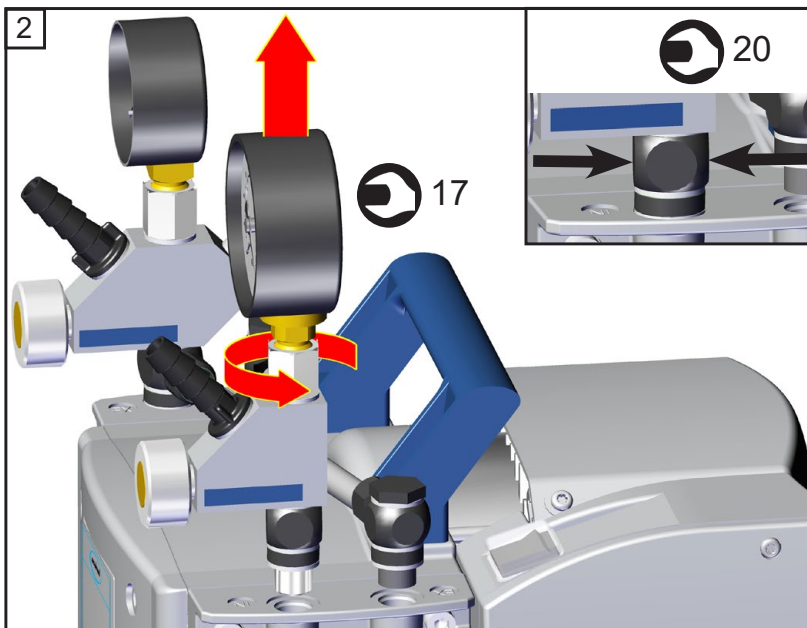

ME 4R NT

17 mm

20 mm

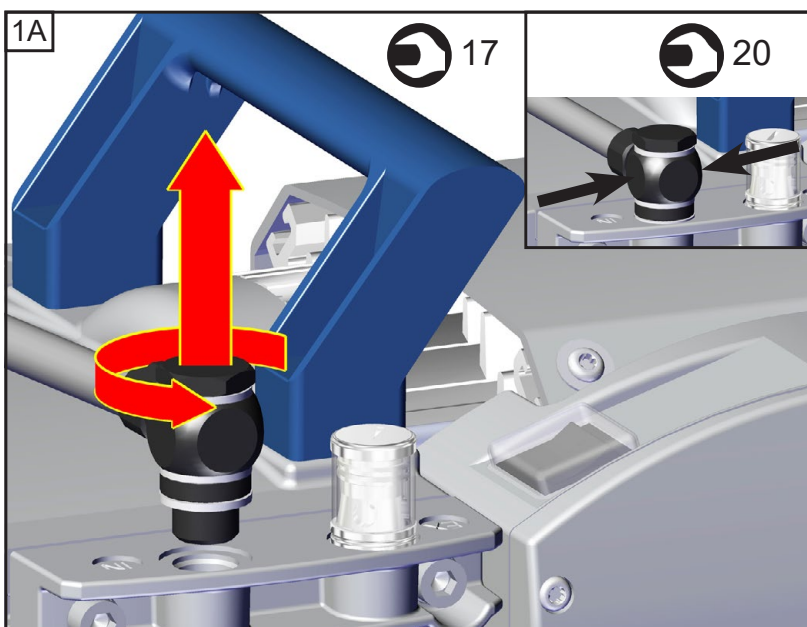

ME 4(S) NT / MZ 2(S) NT

17 mm

20 mm

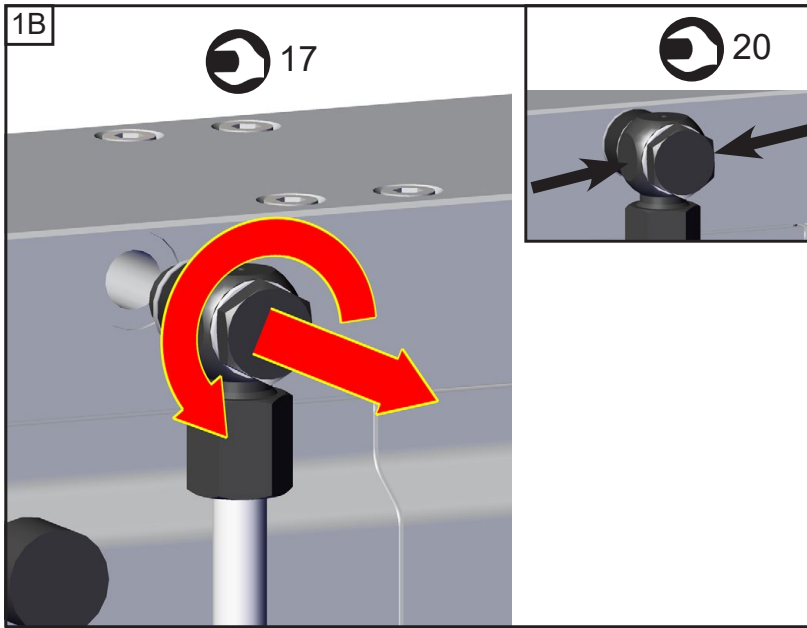

MD 4CRL NT

 17 mm

 20 mm

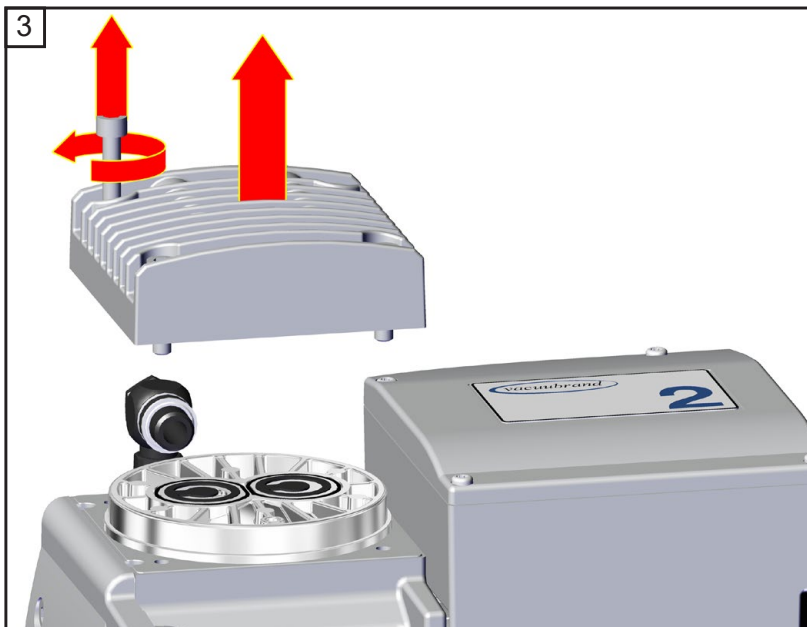

ME 2 NT / ME 4(R, S) NT MZ 2(S) NT

 5
4x

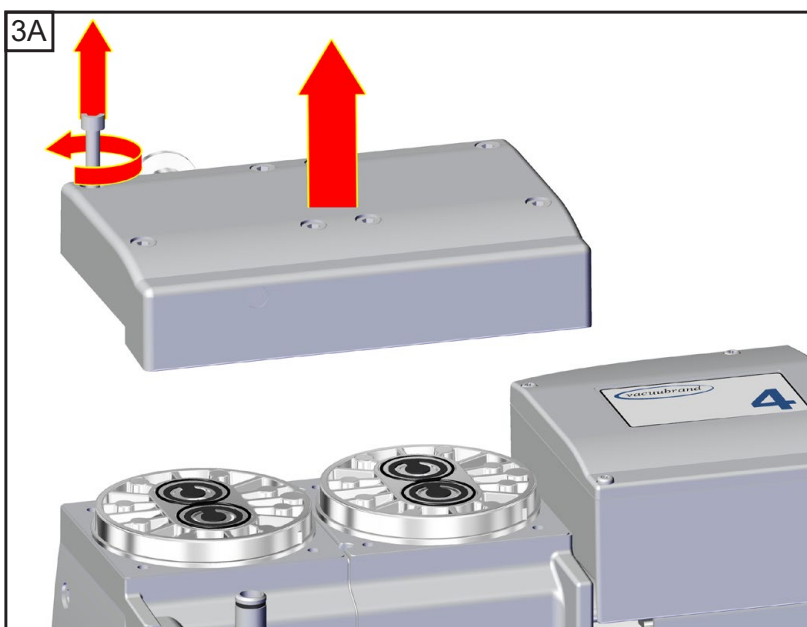

ME 8 NT / MV 2 NT / MD 4(S, CRL) NT

 5
8x

ME 2 NT
ME 4(R, S) NT
MZ 2(S) NT

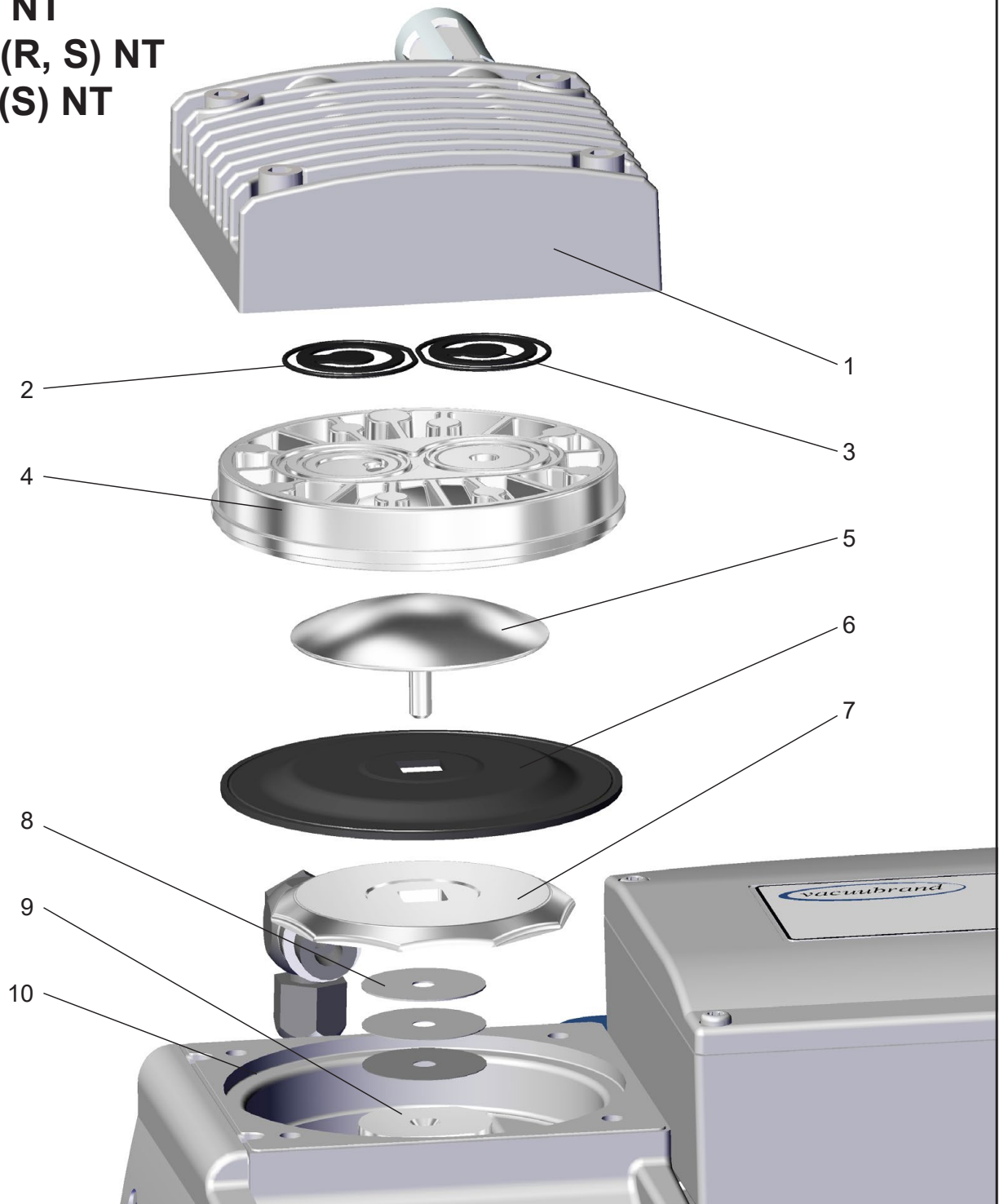

Position	Component
1	Housing cover
2	O-rings
3	Valves
4	Head cover
5	Diaphragm clamping disc with square head screw

Position	Component
6	Diaphragm
7	Diaphragm support disc
8	Washers
9	Connecting rod
10	Housing

**ME 8 NT / MD 4(S, CRL) NT
MV 2 NT**

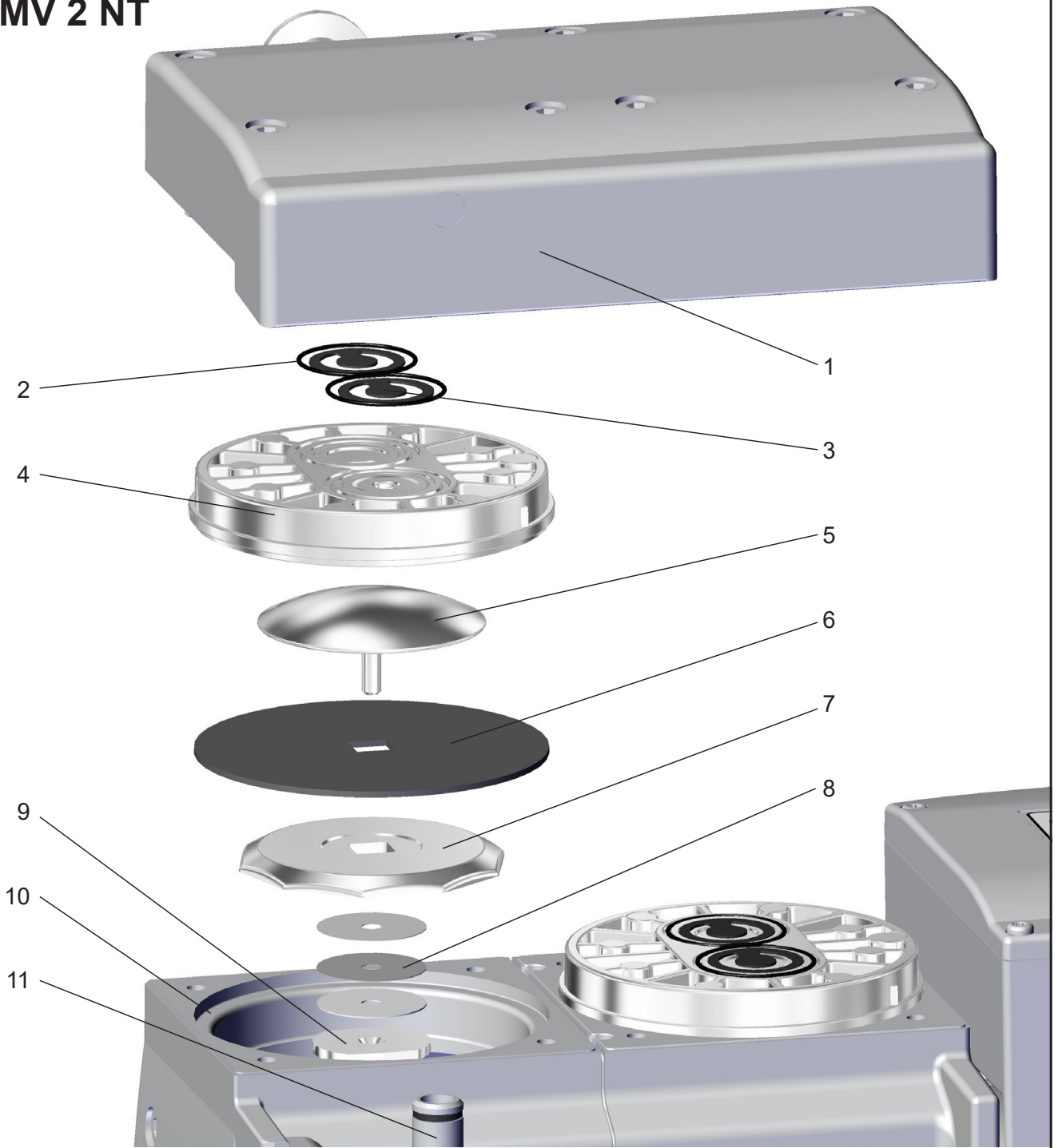

Position	Component
1	Housing cover
2	O-rings (not ME 8 NT)
3	Valves
4	Head cover
5	Diaphragm clamping disc with square head screw
6	Diaphragm

Position	Component
7	Diaphragm support disc
8	Washers
9	Connecting rod
10	Housing
11	Connecting tube with O-ring (MD 4CRL NT with screw-in fitting)

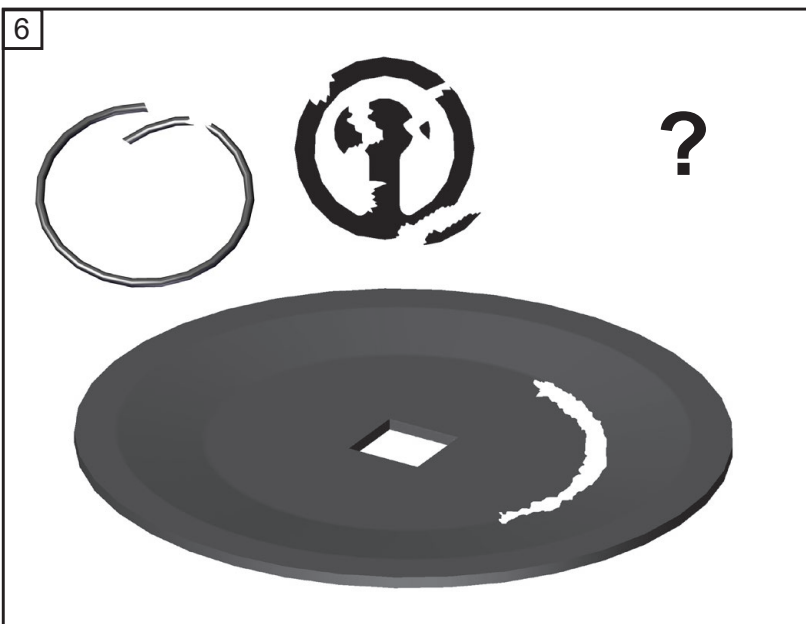
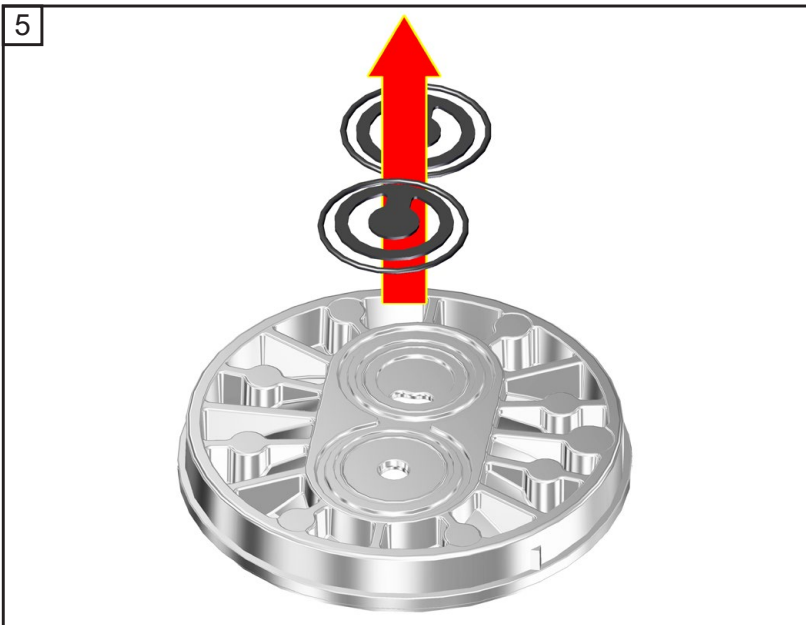
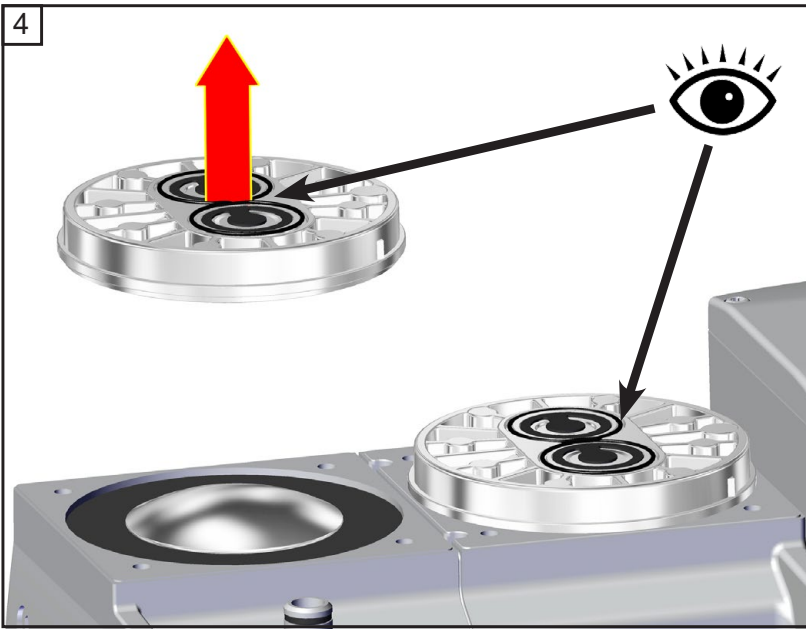

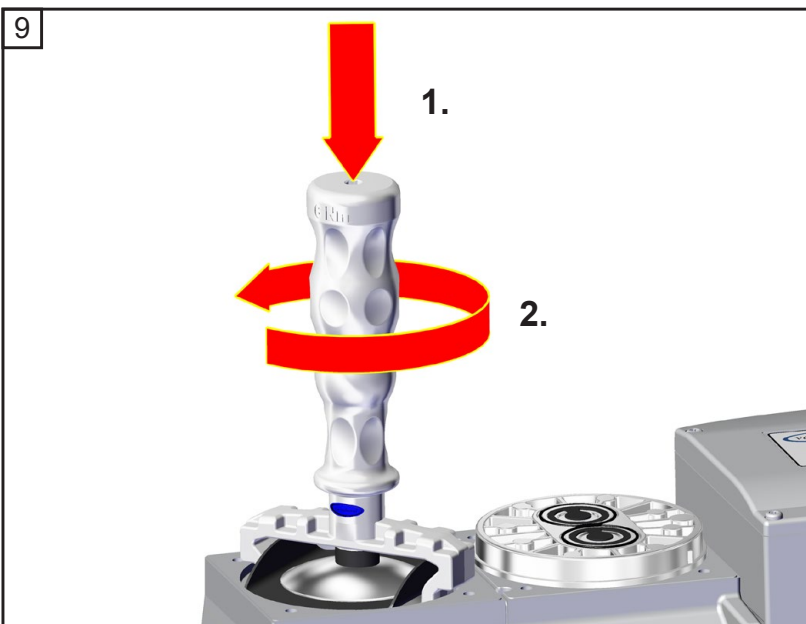
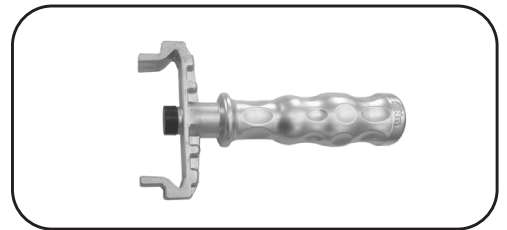
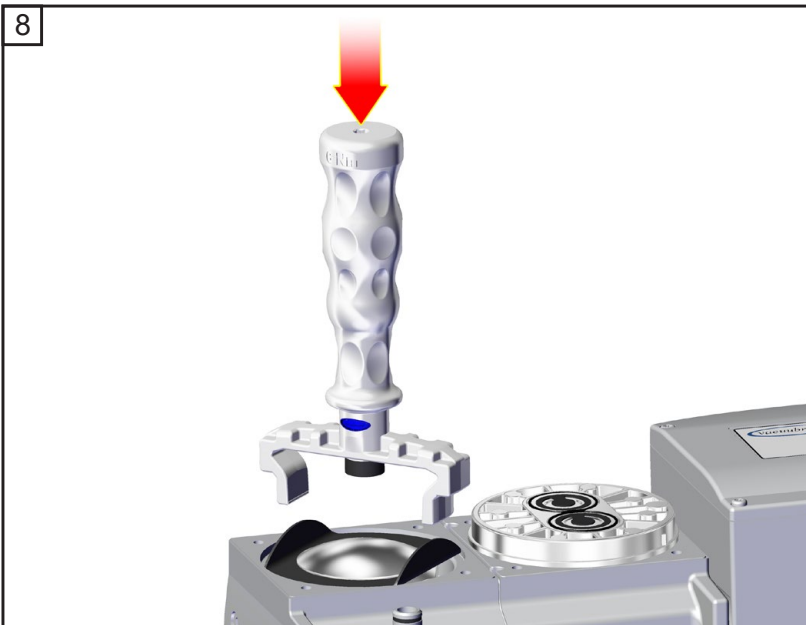
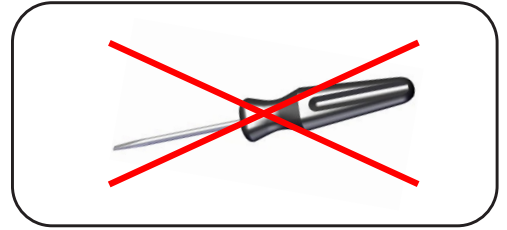

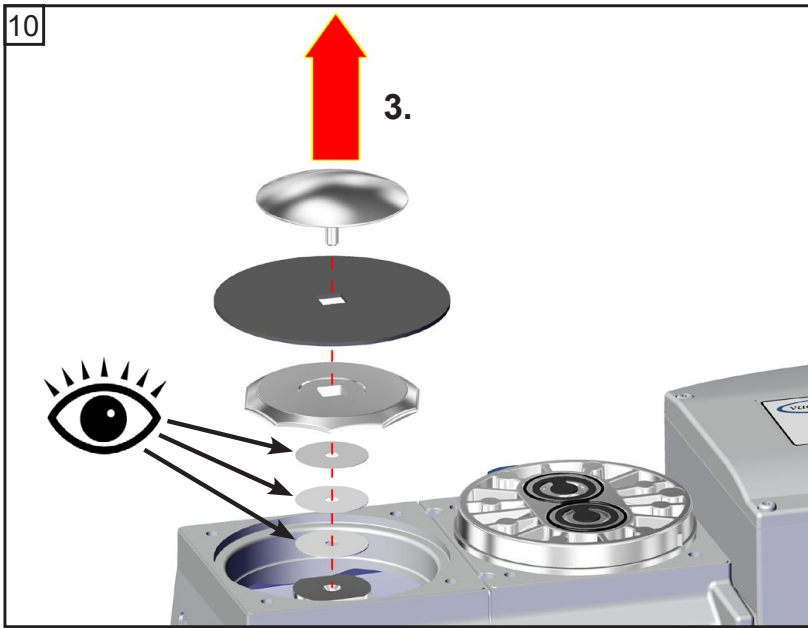

☞ Pay attention to washers!
Assemble same number and thickness.

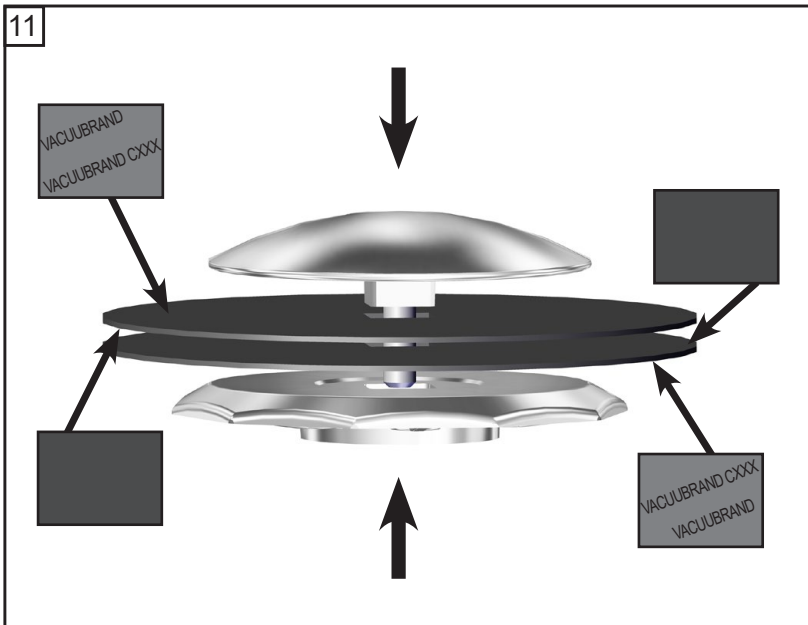

**ME 2 NT / ME 4 NT /
MZ 2 NT / ME 8 NT /
MD 4 NT / MV 2 NT**

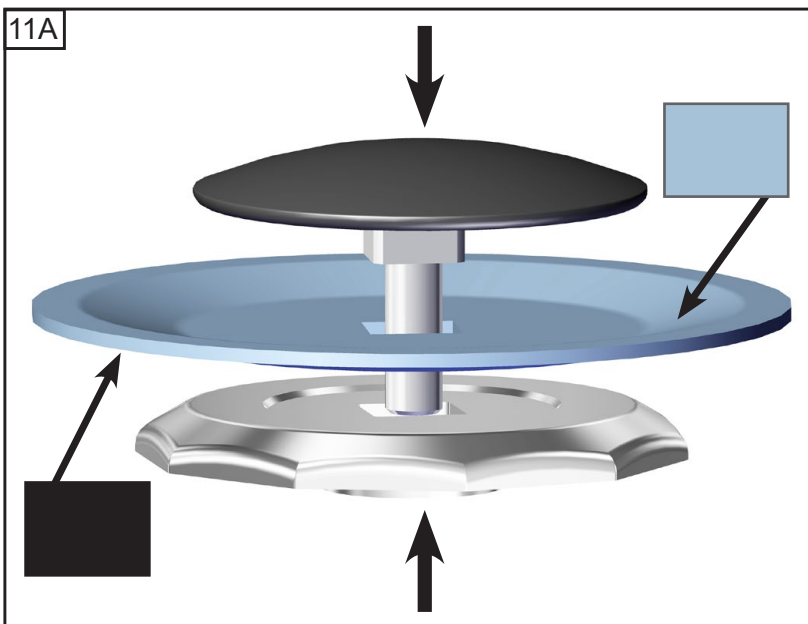
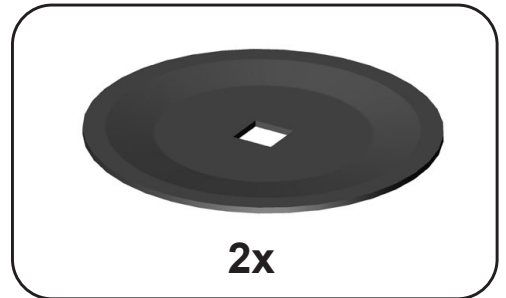

**ME 4S NT / MZ 2S NT /
ME 8S NT / ME 4R NT /
MD 4S NT /
MD 4CRL NT**

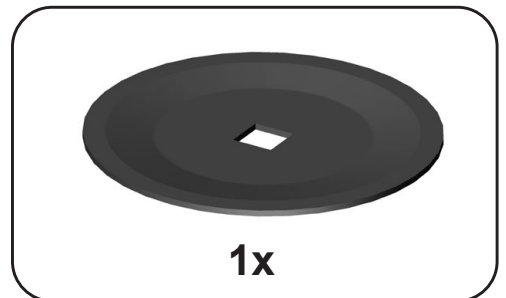

12

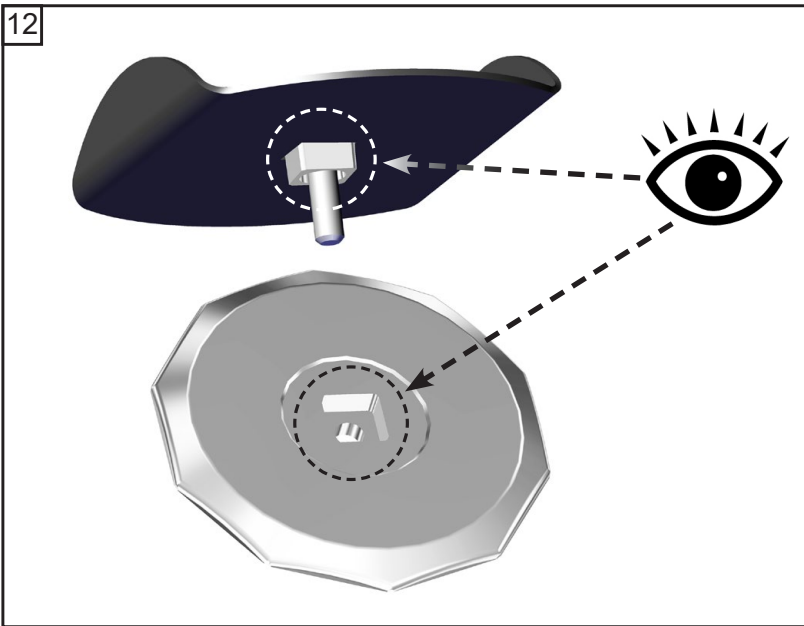

13

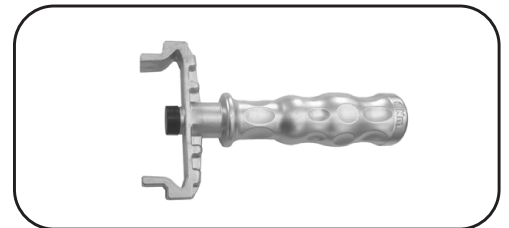
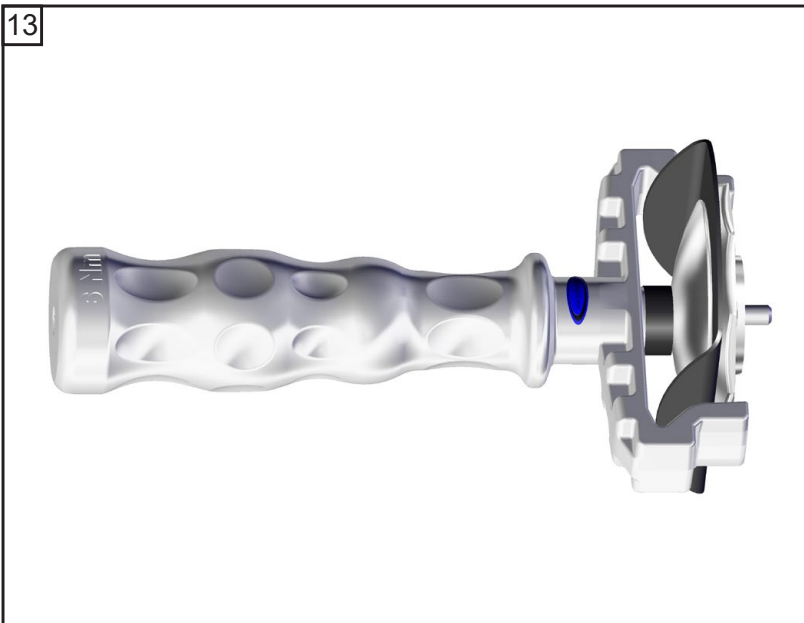

14

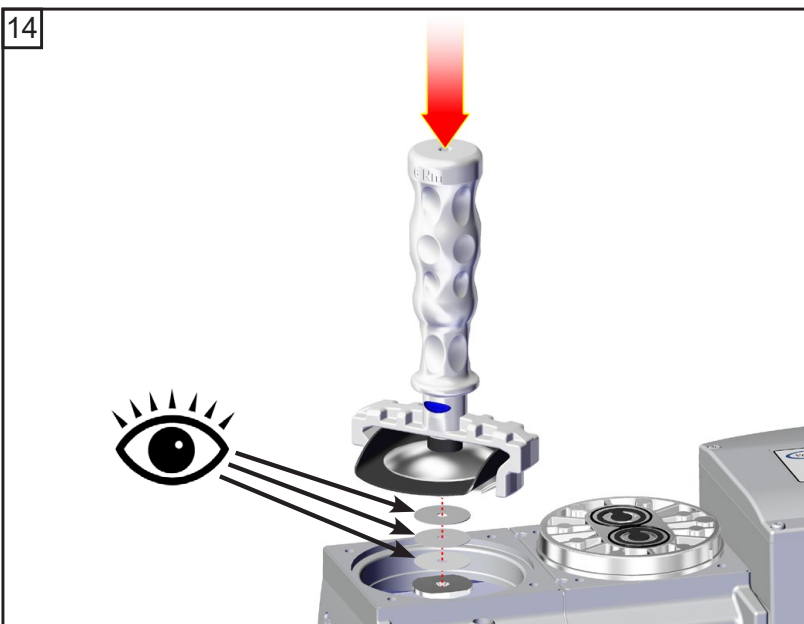

☞ Pay attention to washers! Assemble same number and thickness.

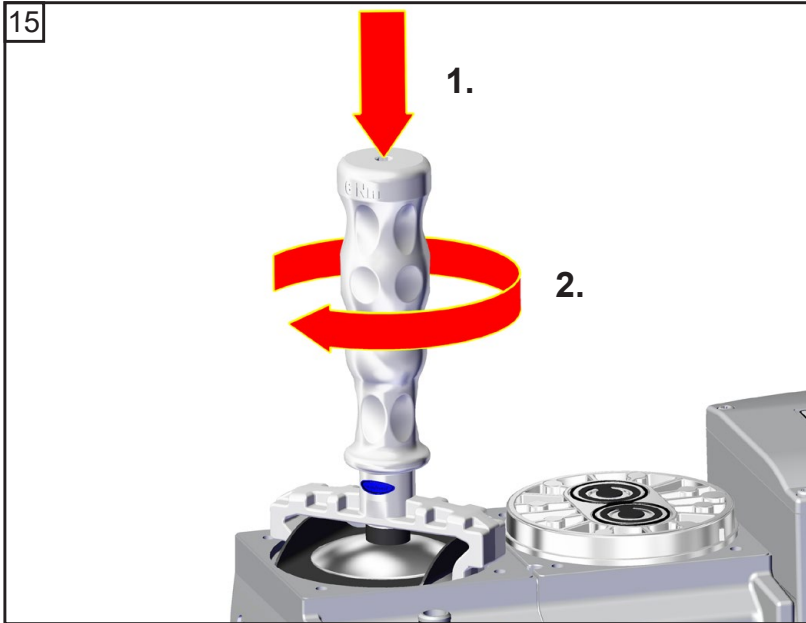

 **4.4 ft.lbf (6 Nm)**

It is recommended to use a torque wrench. Attach torque wrench to diaphragm key (hexagonal bolt  6 mm wide).

Replacing the valves and assembling the pump heads (except MZ 2D NT)

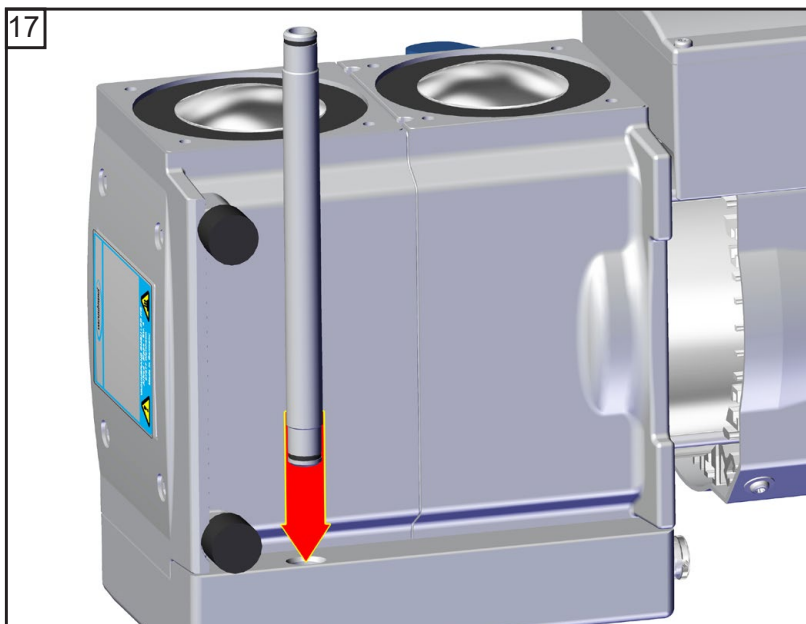
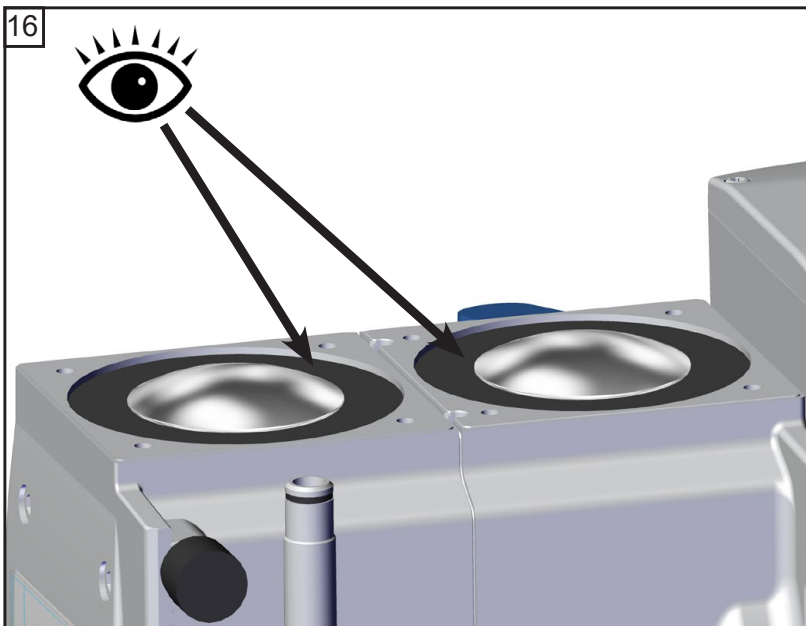

**ME 8 NT / MD 4 NT /
MV 2 NT**

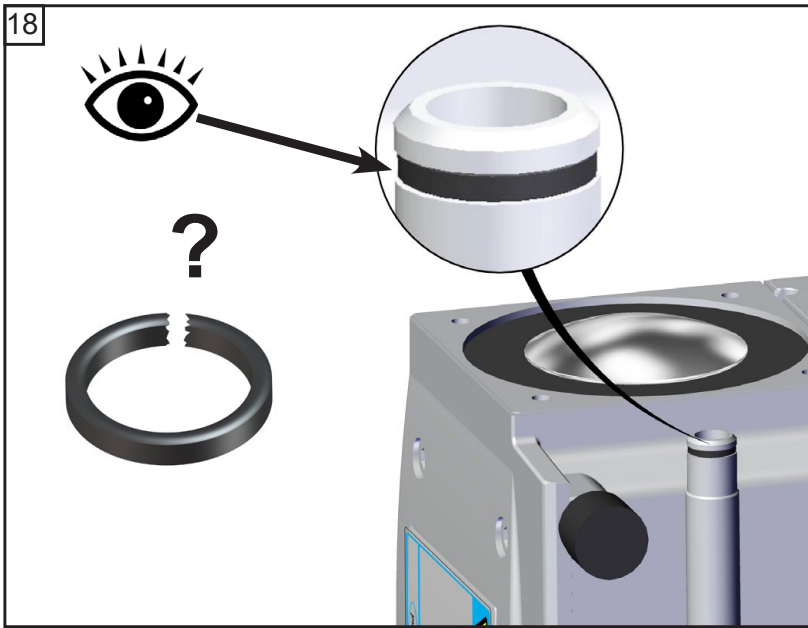

ME 8 NT / MD 4 NT /
MV 2 NT

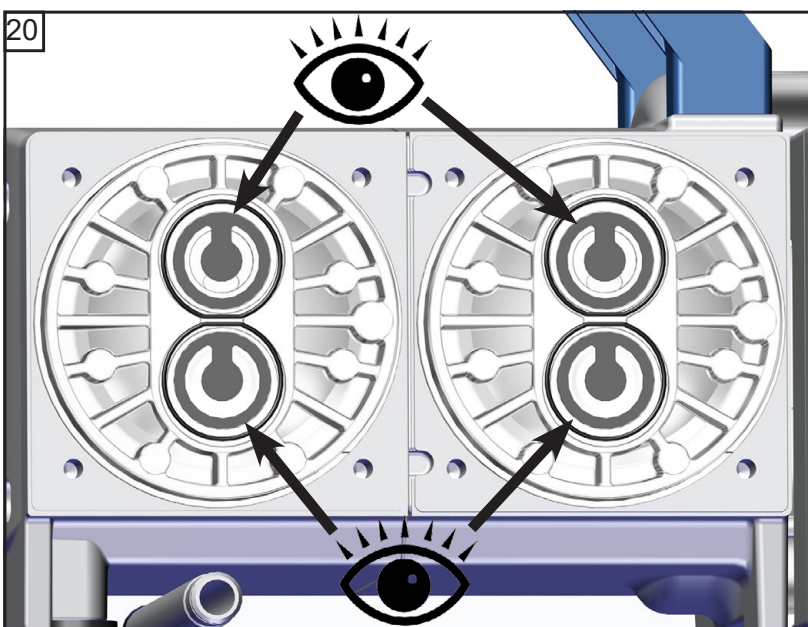
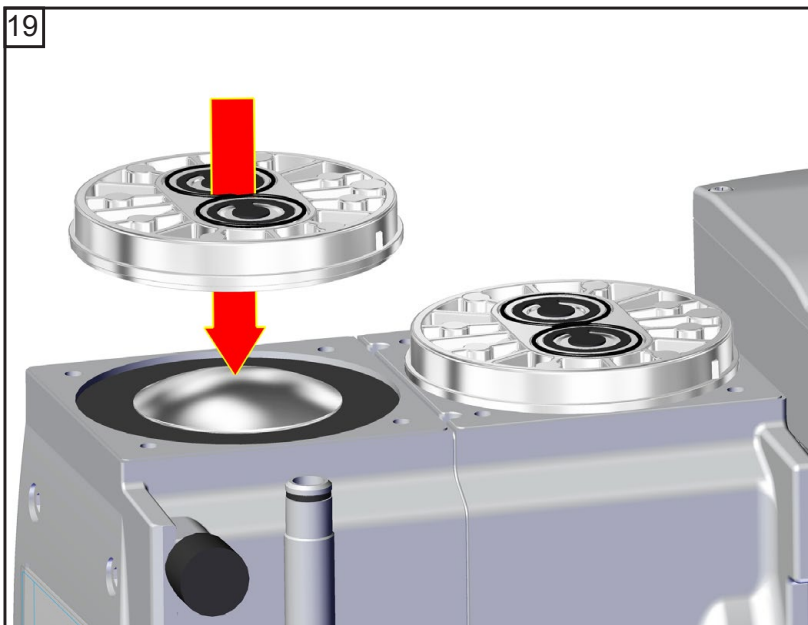
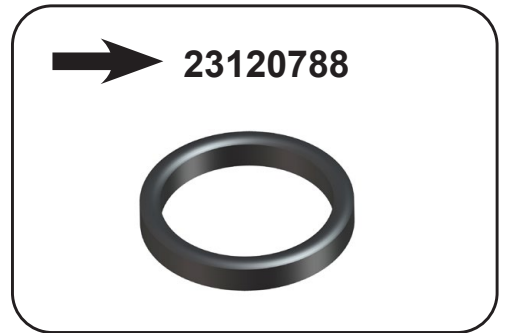

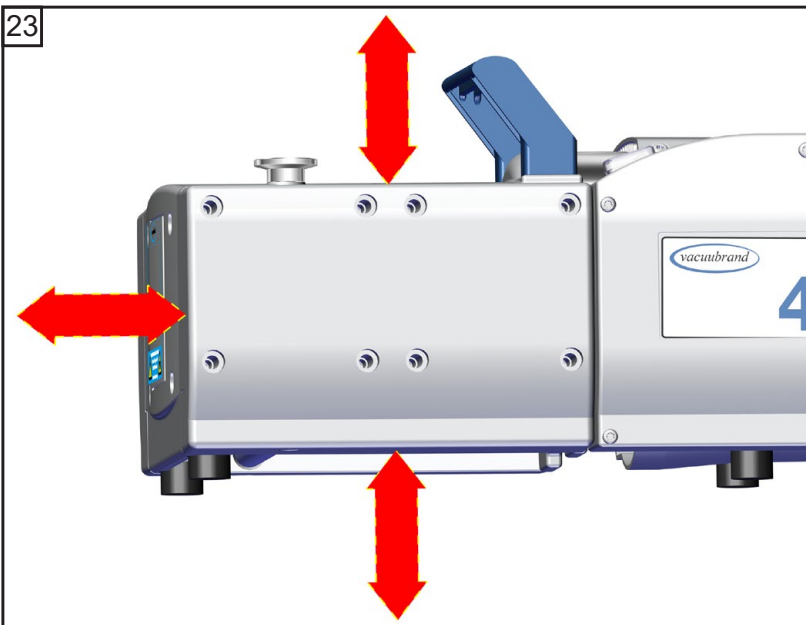
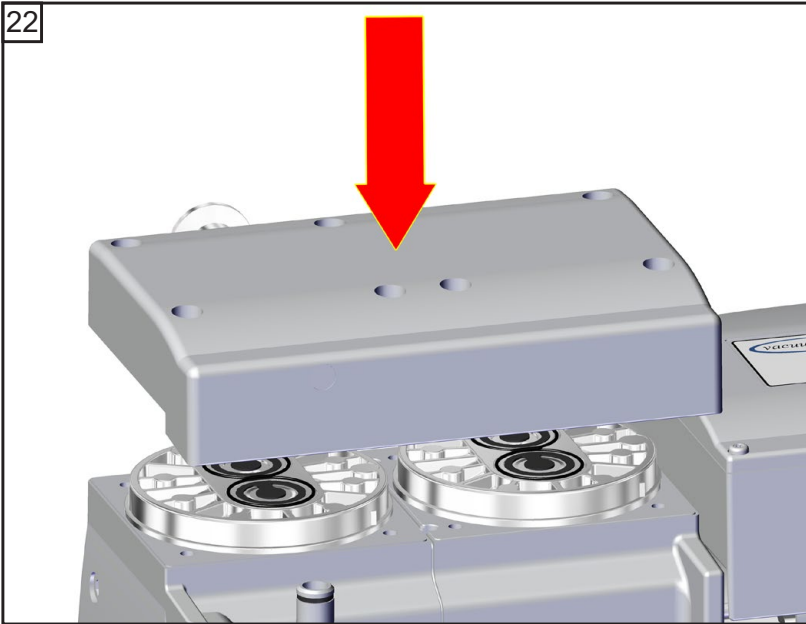
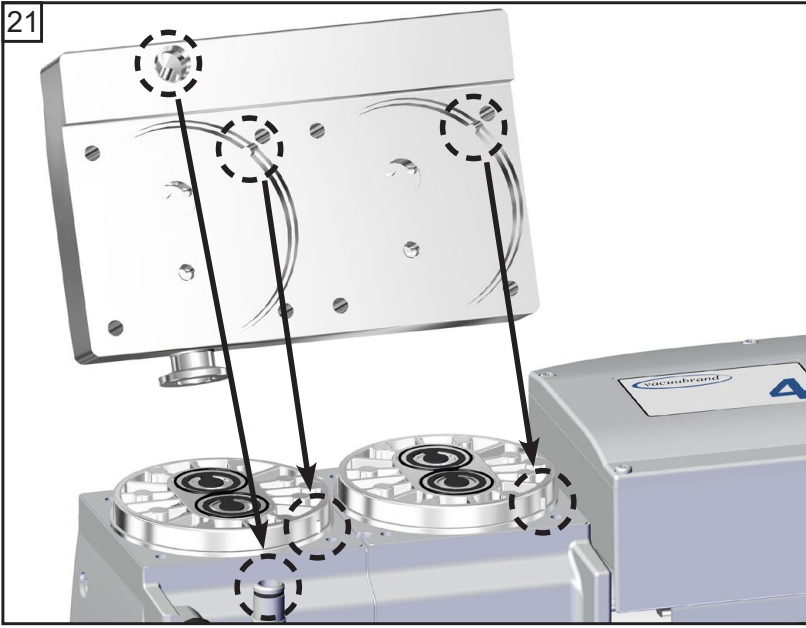

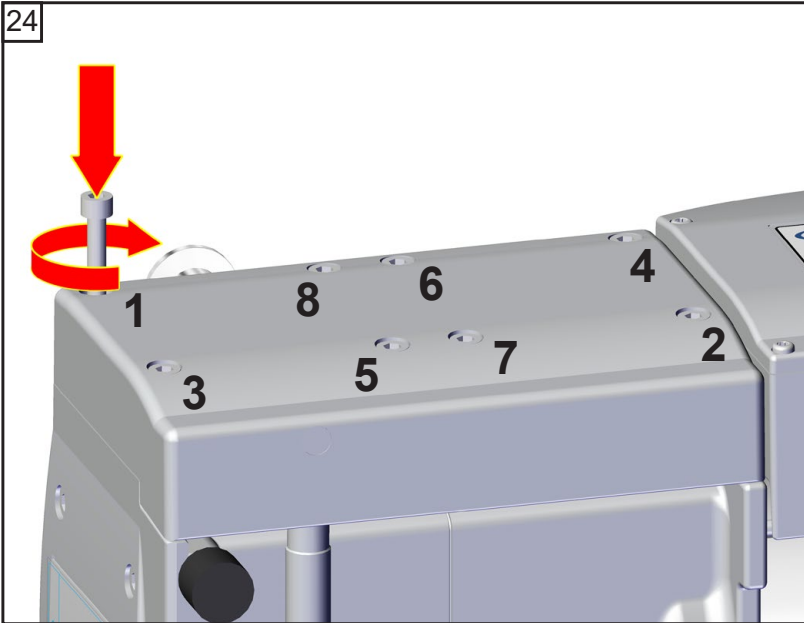

5

8x **ME 8 NT / MV 2 NT**
MD 4(S, CRL) NT
 (1 - 8)

4x **ME 2 NT /**
ME 4(R, S) NT /
MZ 2(S) NT (1 - 4)

☞ A: 1 - 8 (1 - 4)

hand-tight

☞ B: 1 - 8 (1 - 4)

8.9 ft.lbf (12 Nm)

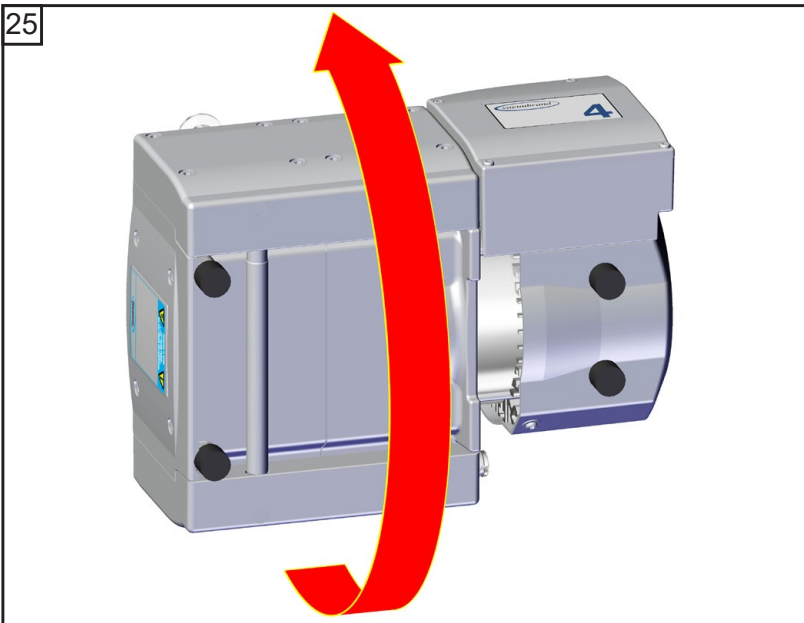

☞ Maintain all pump heads in the same way.

**Assembling the connecting hose
 (ME 4(R, S) NT, MZ 2(S) NT, MD 4CRL NT)**

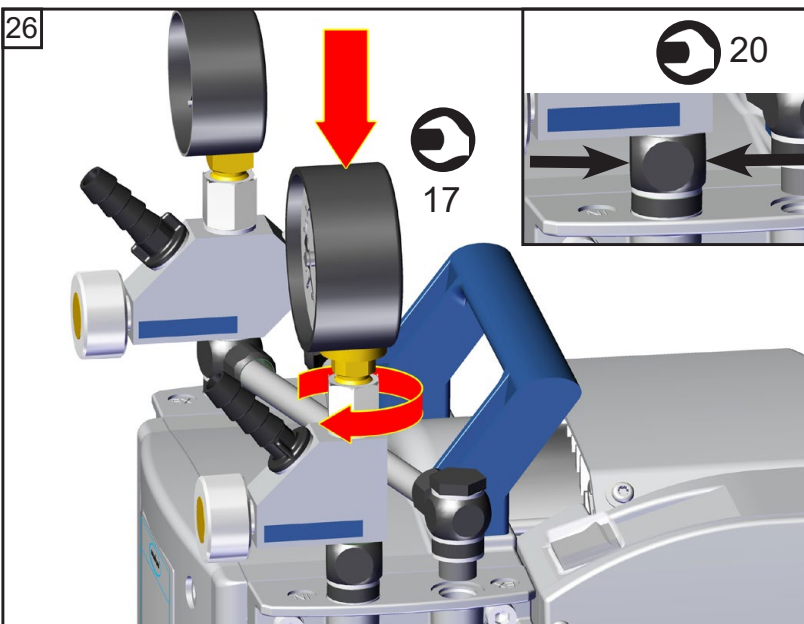

ME 4R NT

17 mm

20 mm

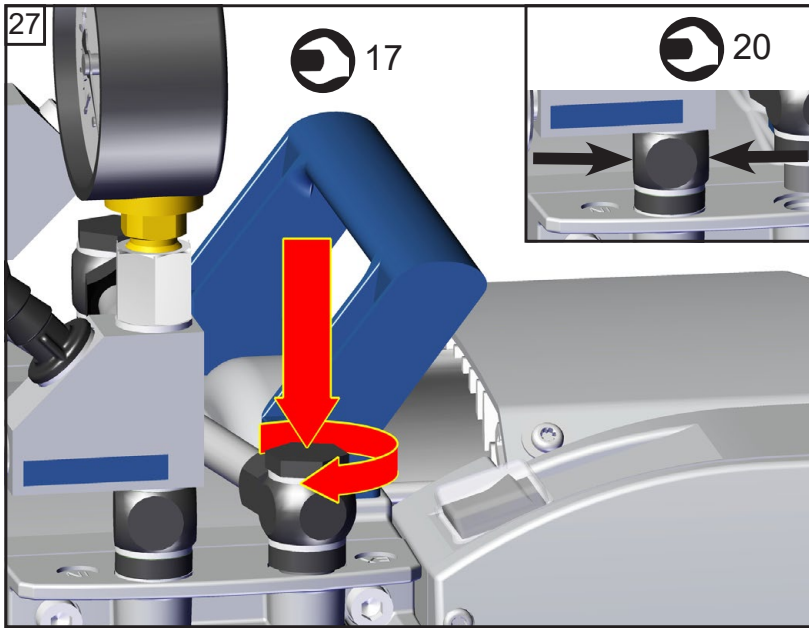

ME 4R NT

 17 mm

 20 mm

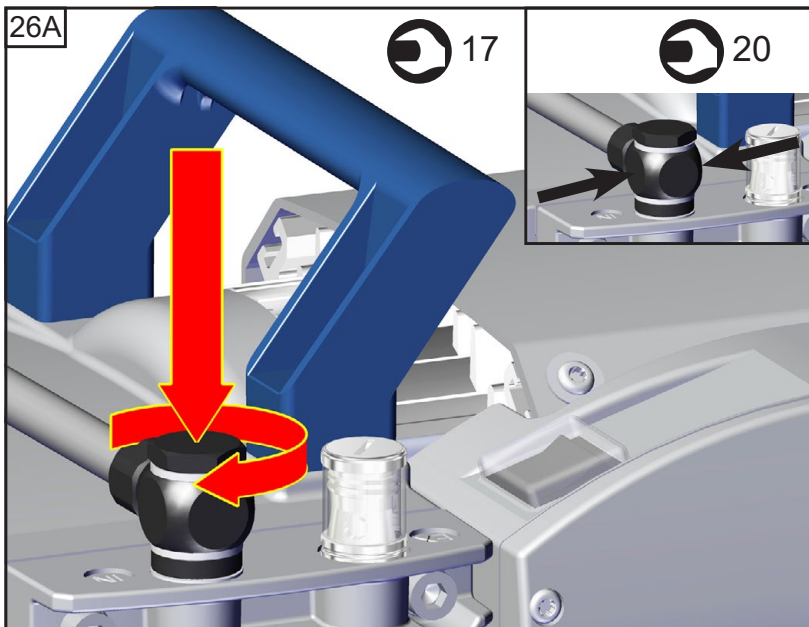

ME 4(S) NT / MZ 2(S) NT

 17 mm

 20 mm

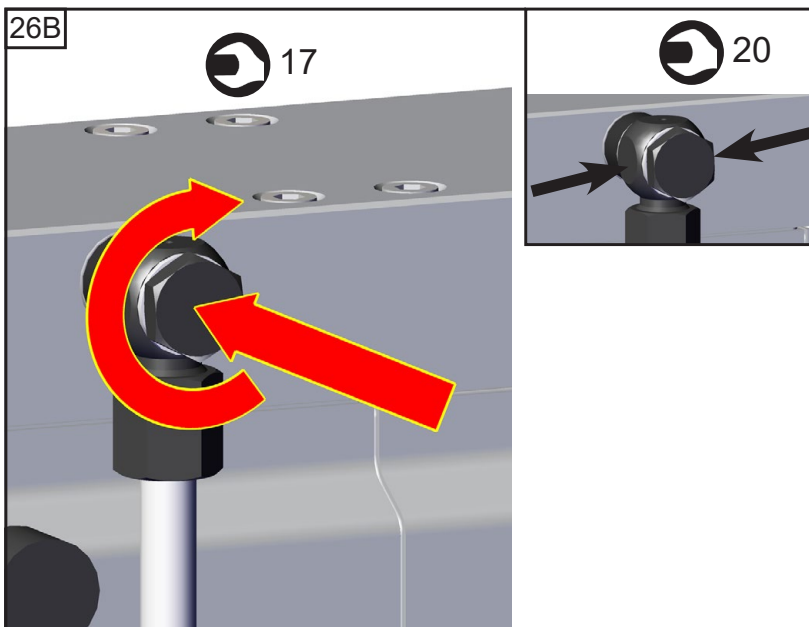

MD 4CRL NT

 17 mm

 20 mm

Checking diaphragms and valves (MZ 2D NT)

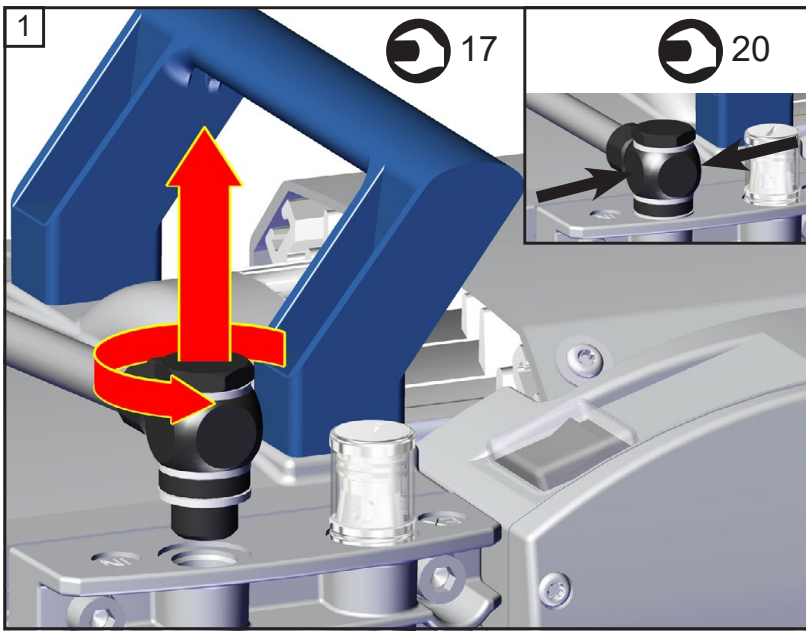

 17 mm

 20 mm

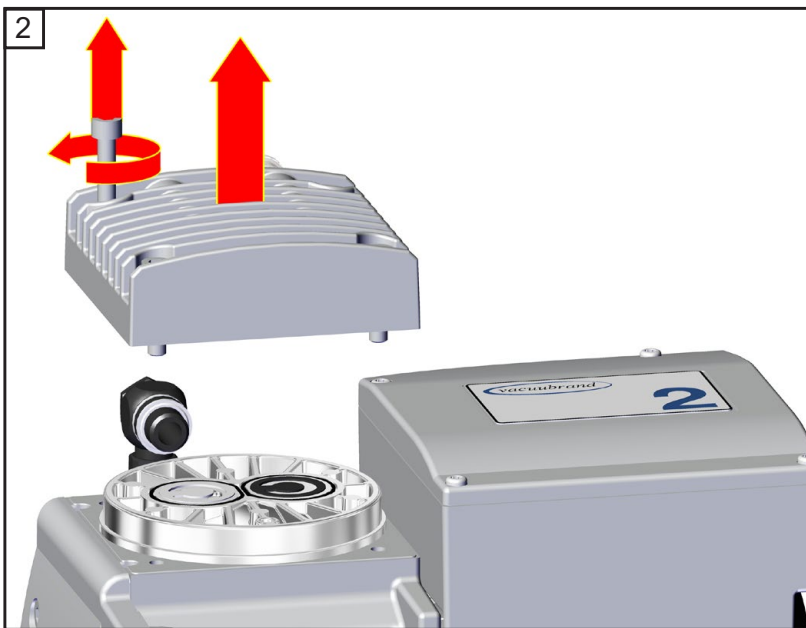

 5
4x

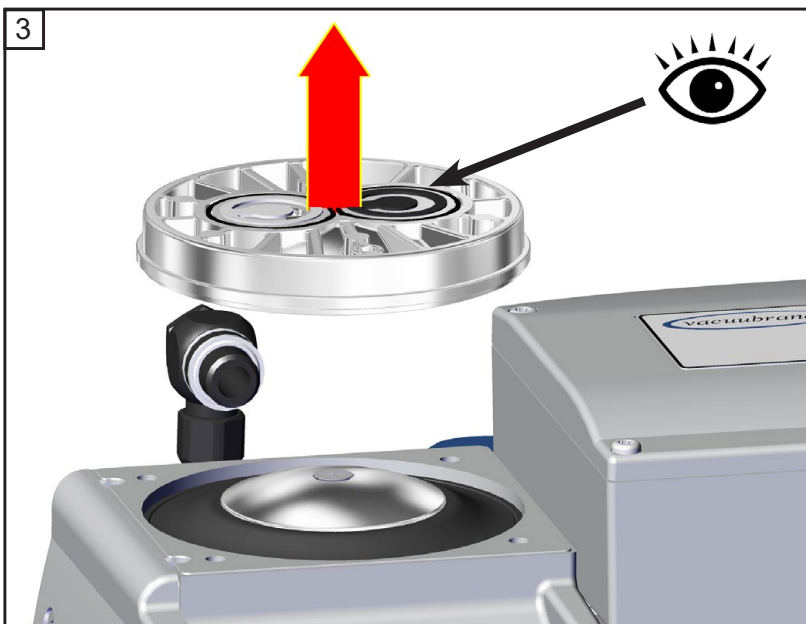

MZ 2D NT

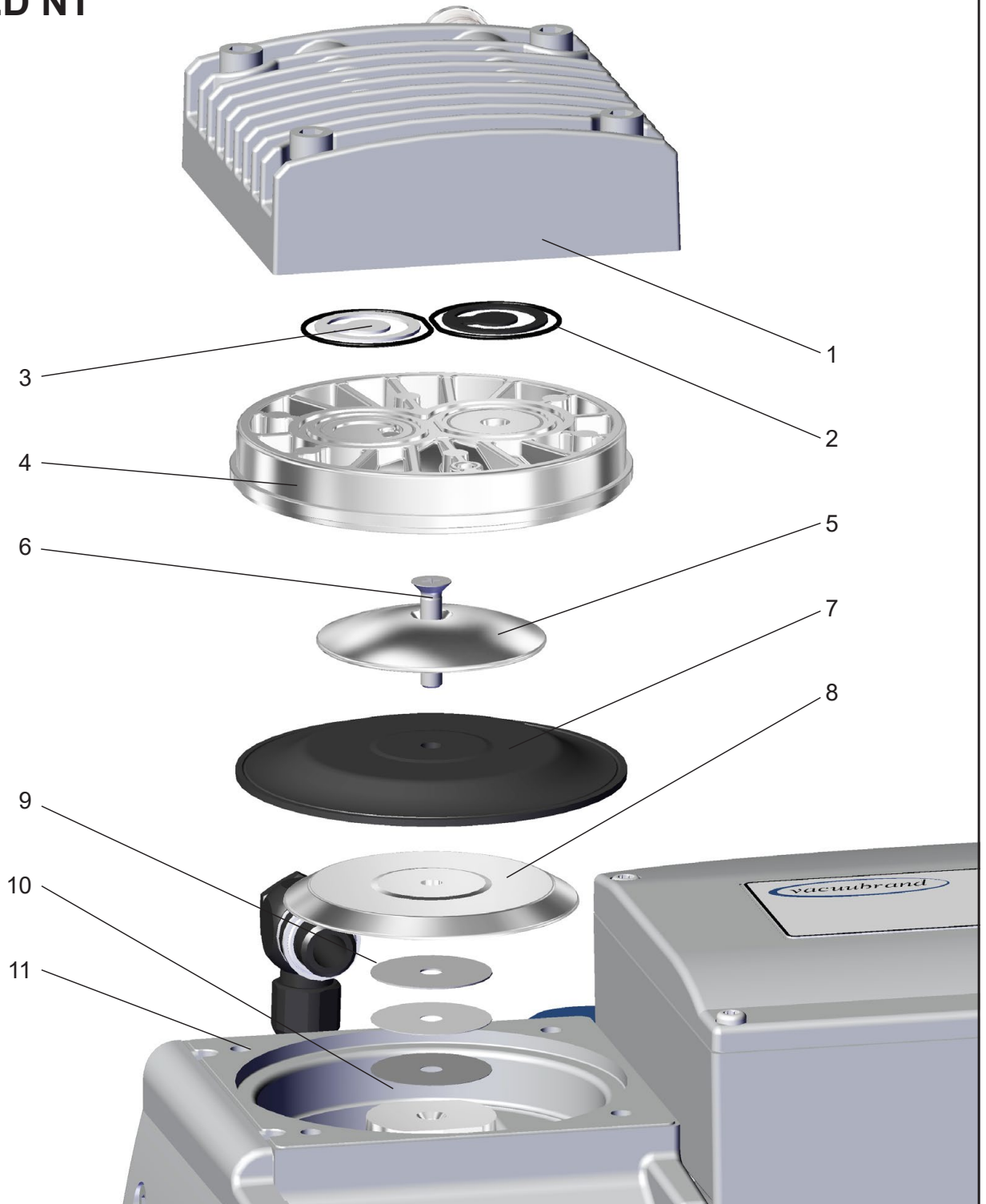

Position	Component
1	Housing cover
2	O-rings
3	Valves
4	Head cover
5	Diaphragm clamping disc
6	Countersunk head screw

Position	Component
7	Diaphragm
8	Diaphragm support disc
9	Washers
10	Connecting rod
11	Housing

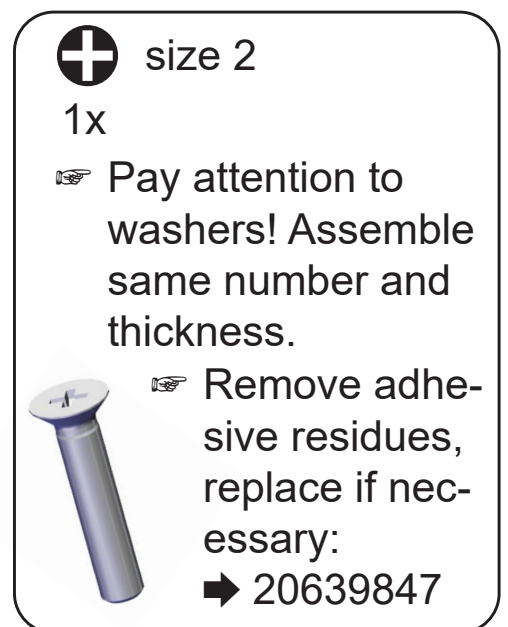
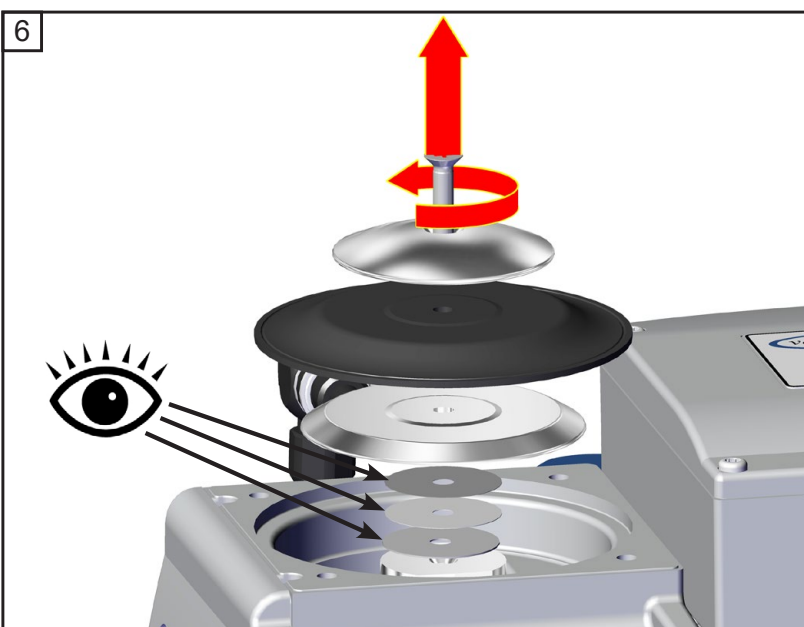
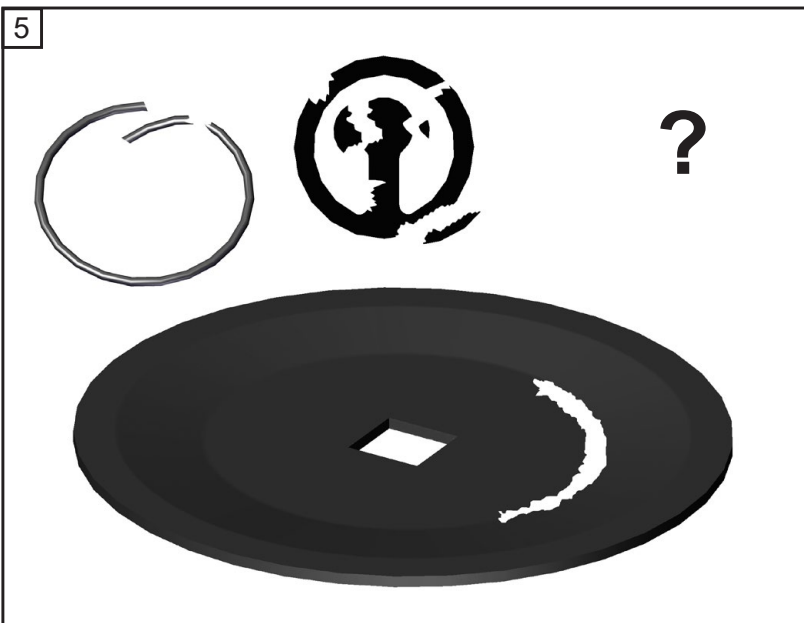
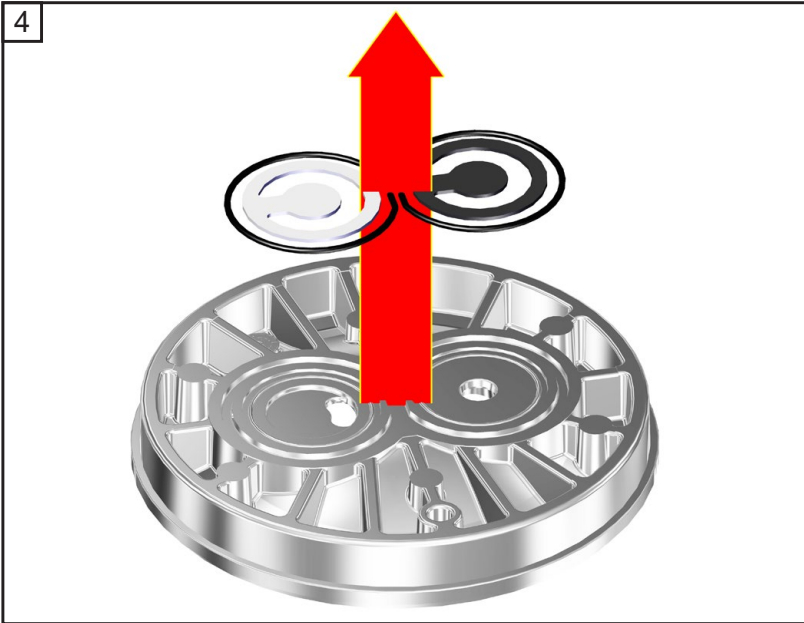

7

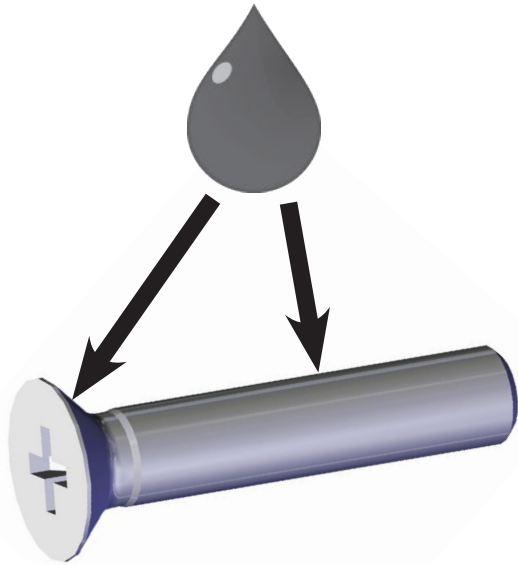

2x

Adhesive
(OmniFit® 50M
or Loctite® 243)

OmniFit® and Loctite® are registered trade marks of Henkel Technologies

8

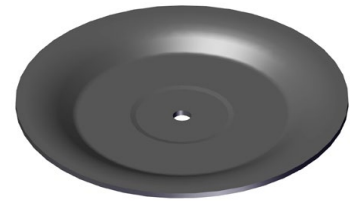
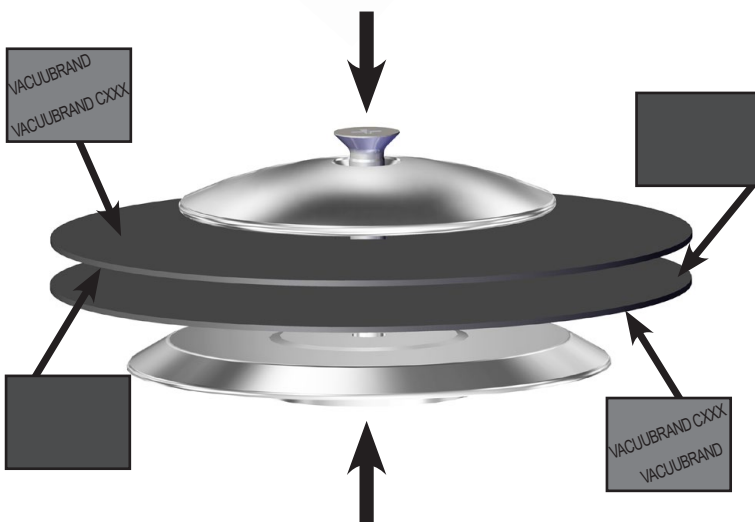

2x

9

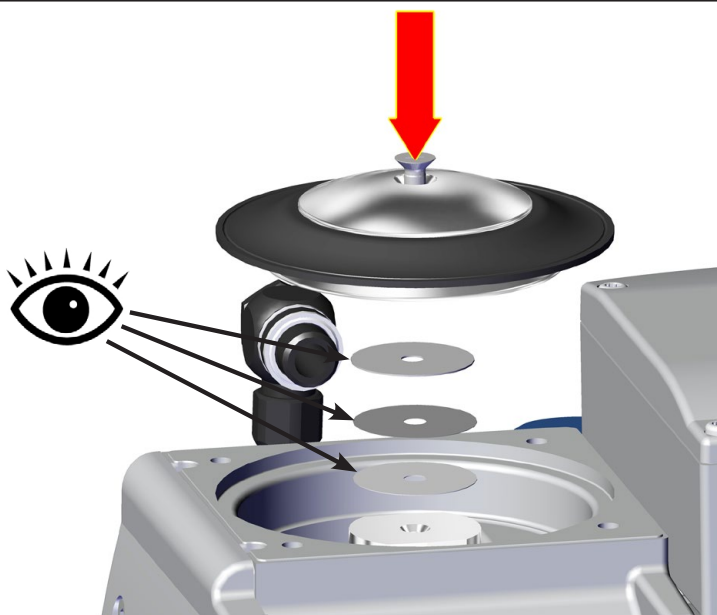

☞ Pay attention to washers!
Assemble same number and thickness.

10

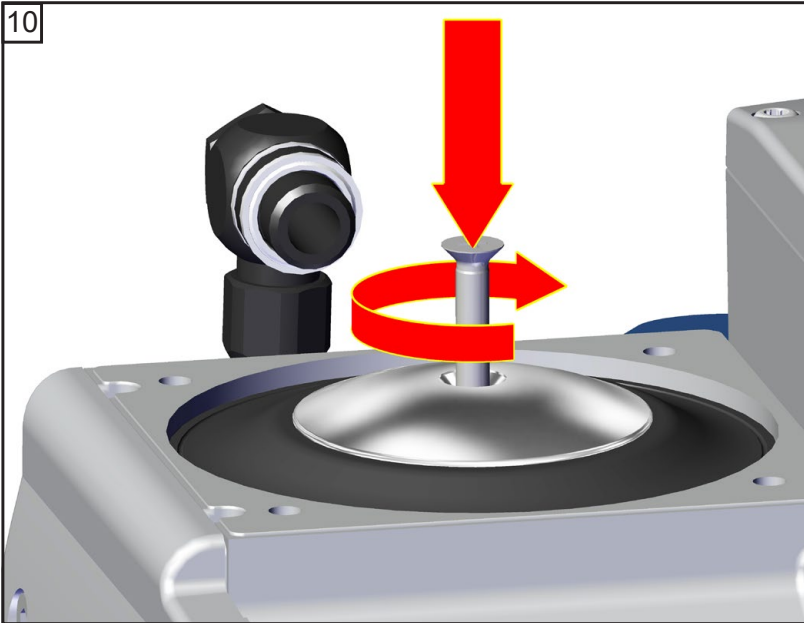

⊕ size 2
1x

***Replacing the valves and assembling the pump heads
(MZ 2D NT)***

11

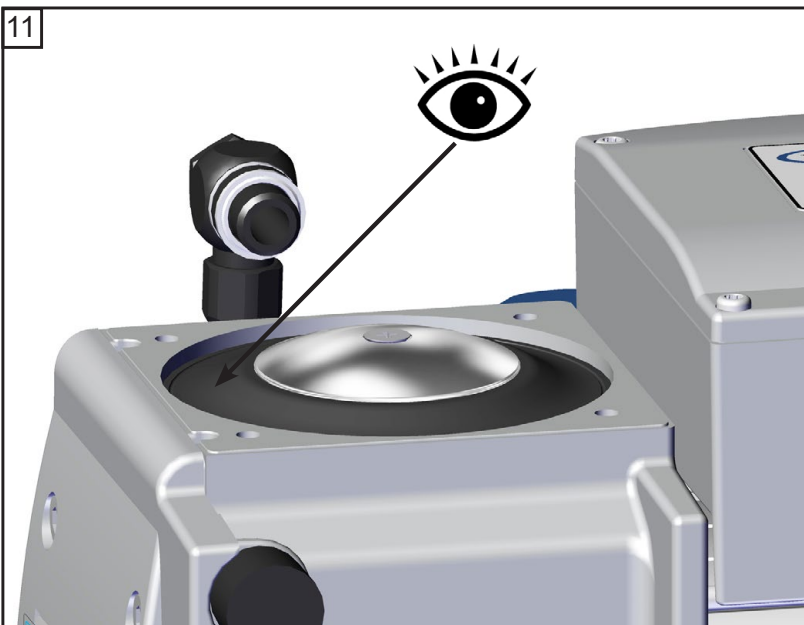

12

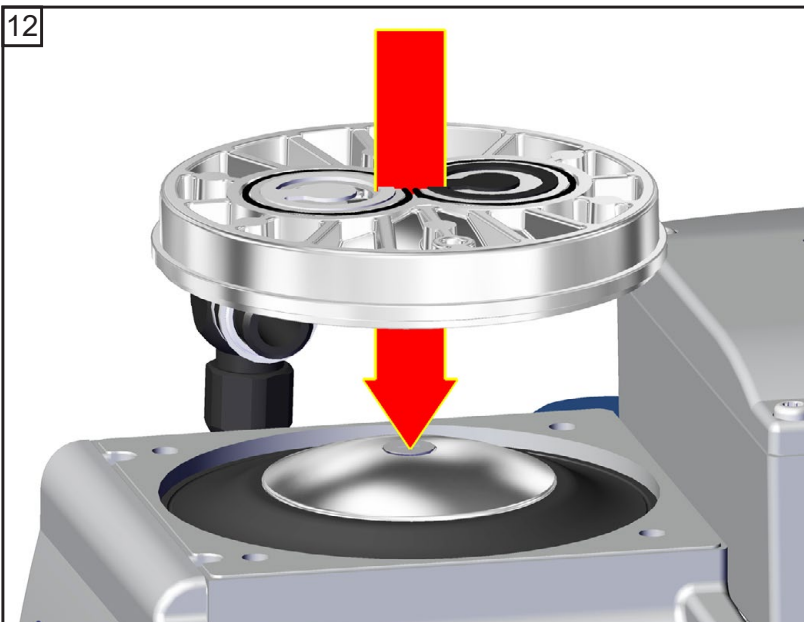

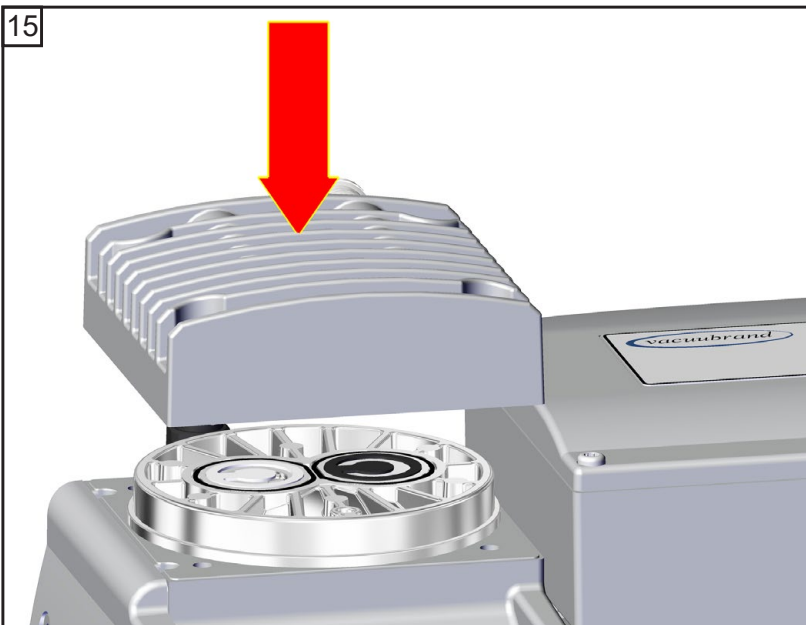
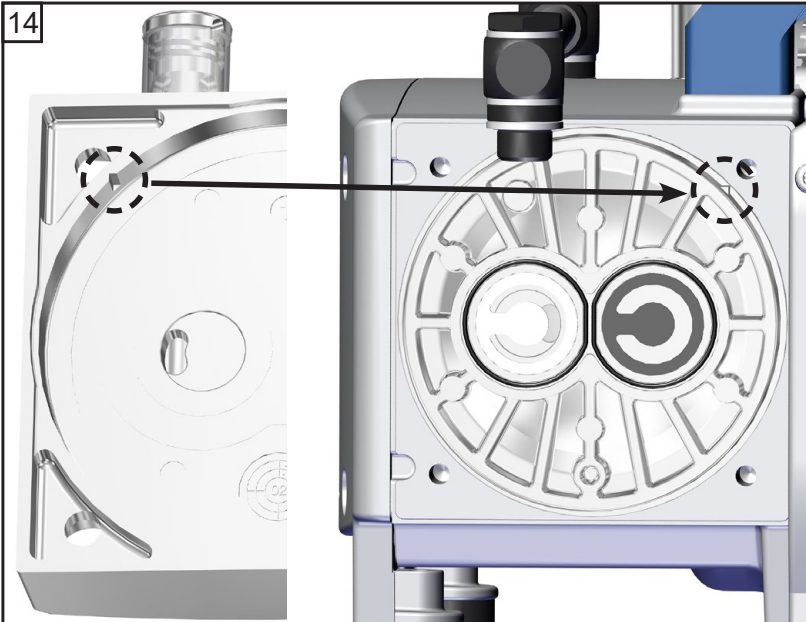
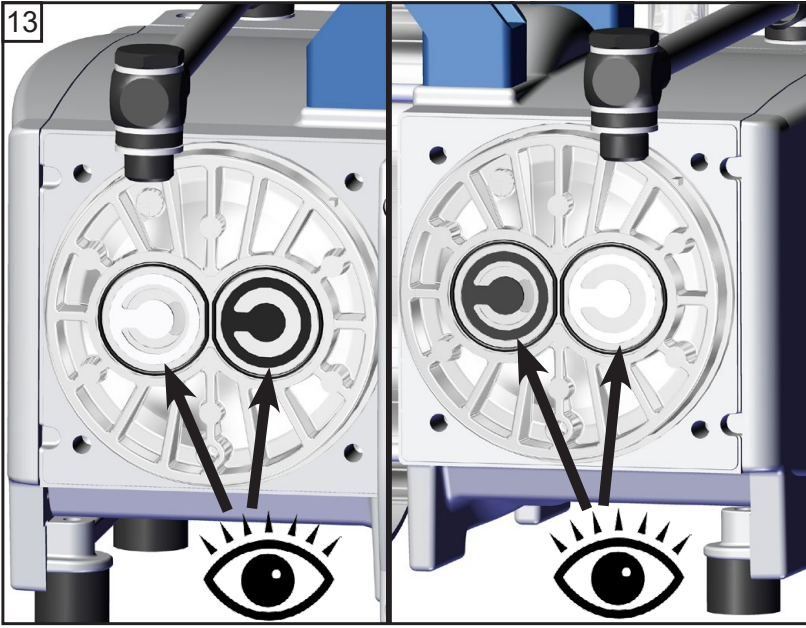

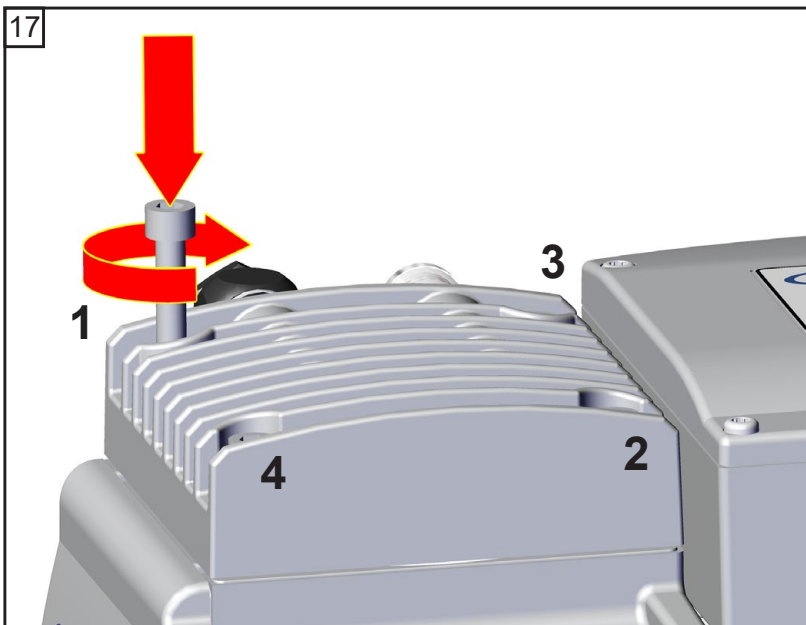
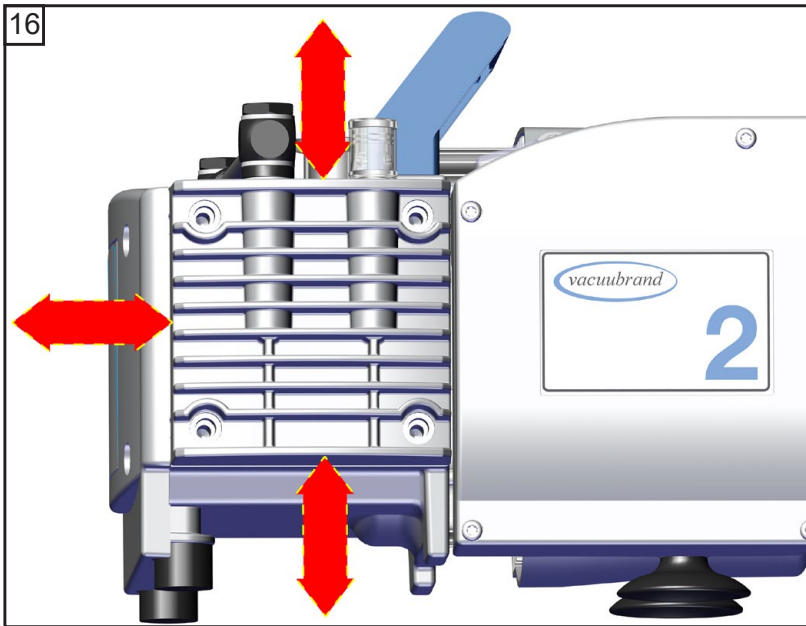

4x

👉 A: 1 - 4 hand-tight

👉 B: 1 - 4
8.9 ft.lbf (12 Nm)

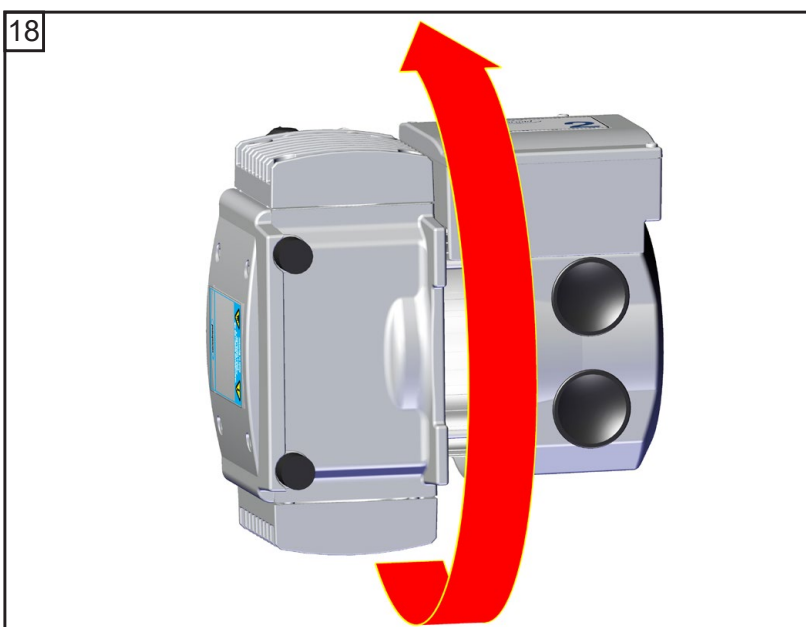

👉 Maintain all pump heads in the same way.

Assembling the connecting hose (MZ 2D NT)

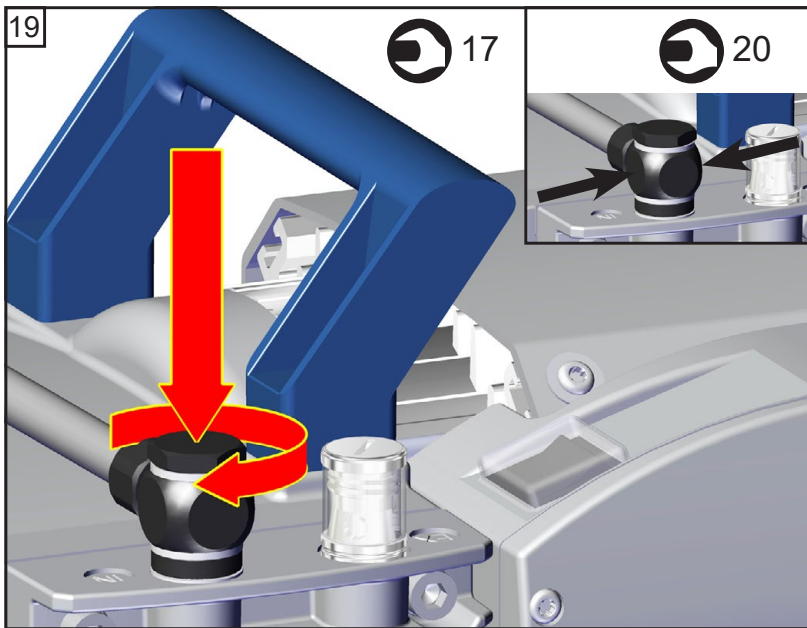

 17 mm

 20 mm

Checking the ultimate vacuum

- ➔ After any intervention at the equipment (e.g., repair / maintenance) the ultimate vacuum of the pump has to be checked. Only if the pump achieves its specified ultimate vacuum, the pump's leak rate is low enough to ensure that no explosive atmospheres will occur in the interior of the equipment.

If the pump does not achieve the ultimate vacuum:

- Whenever the diaphragms and valves have been replaced, a break-in period of several hours is required before the pump achieves its ultimate vacuum.
- In case of an unusual noise, switch off pump immediately and check clamping disc positions.

If the specified ultimate vacuum is not achieved, and if this does not change after the break-in period:

Check hose connectors at pump heads for leaks. If necessary recheck valve seats and pump chambers.

MD 4CRL NT:

- ➔ **Note:** Always perform a leak test using an appropriate leak detector (e.g., helium leak detector) after opening the pump! Leak rate (integral) see "Technical data", pg. 26.

Replacing the fuse

DANGER

➔ Danger due to electrical voltage.



➔ **Switch off the pump.**

➔ **Disconnect the electrical power cord** before opening the terminal box. After disconnecting from power, **wait five seconds** to allow the capacitors to discharge.

WARNING

☞ The replacing of the fuse has to be carried out by a trained electrician.

☞ After replacing the fuse, the pump must be checked for electric safety (see below)! Identify and eliminate the cause of failure before switching on the pump again.



 T20
4x

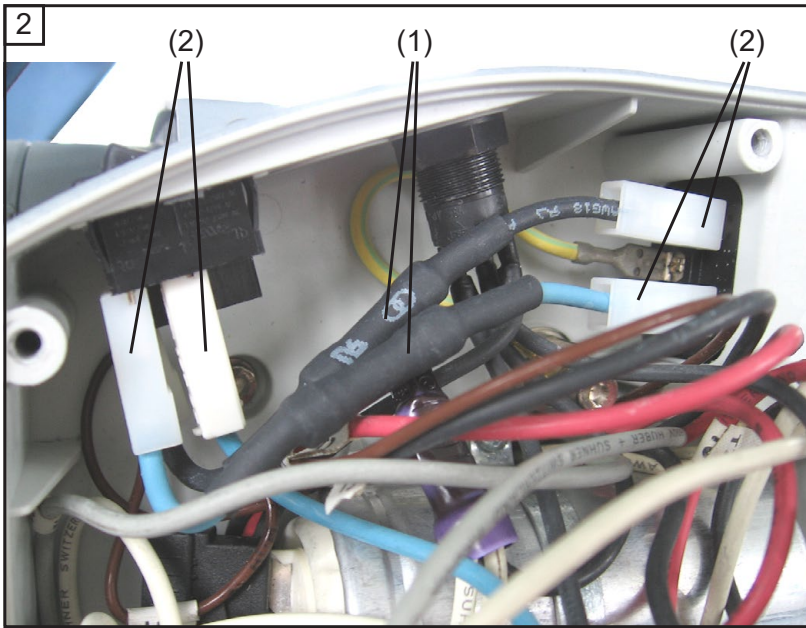

➔ **20636542**

✎ The pigtail fuses are integrated into wires ((1), black and blue) inside the terminal box. To replace the fuses it is necessary to replace both wires completely (fixed with flat pin bushings (2)).

➔ Remove both wires with integrated fuses (fixed with flat pin bushings (2), see figure). Mount the new wires (flat pin bushings).

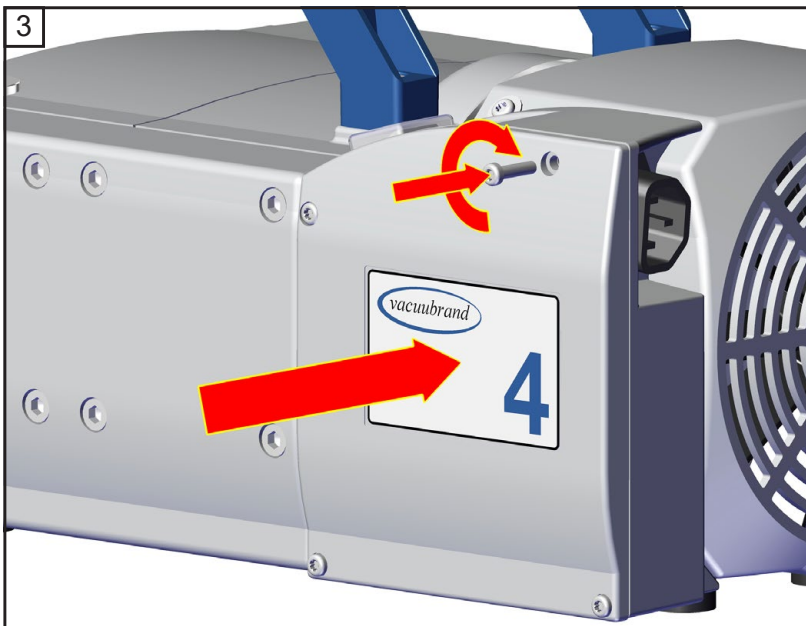

★ T20
4x

⚠ WARNING

Important: Check operability and safety of the pump after repair and after replacing the device fuse.

Check the electrical safety (protective conductor resistance, insulating resistance, high voltage test) according to IEC 61010 and national regulations.

Repair - Maintenance - Return - Calibration

IMPORTANT

Every employer (user) is held responsible for the health and safety of his employees. This also applies to service personnel performing repair, maintenance, return or calibration.

The **health and safety clearance form** informs the contractor about any possible contamination of the device and forms the basis for the risk assessment.

In case of devices which have been in contact with biological substances of risk level 2 contact the VACUUBRAND service absolutely before dispatching the device. These devices have to be completely disassembled and decontaminated by the user prior to shipment. Do not return devices which have been in contact biological substances of risk level 3 or 4. These devices cannot be checked, maintained or repaired. Also decontaminated devices must not returned to VACUUBRAND due to a residual risk. The same conditions apply to on-site work.

No repair, maintenance, return or calibration is possible unless the correctly completed health and safety clearance form is returned. Devices sent are rejected if applicable. Send a completed copy of the **health and safety clearance form** to us in advance. The declaration must arrive before the equipment. Enclose a second completed copy with the product.

Remove all components from the device that are no original VACUUBRAND components. VACUUBRAND will not be responsible for lost or damaged components that are no original components.

Drain the device completely of fluids and residues. Decontaminate the device. Close all openings airtight especially if using substances hazardous to health.

To expedite repair and to reduce costs, please enclose a detailed description of the problem and the product's operating conditions with every product returned.

If you do not wish a repair on the basis of our **quotation**, the device may be returned to you disassembled and at your expense.

In many cases, the components must be cleaned in the factory prior to repair.

For cleaning we use an environmentally friendly water based process. Unfortunately the combined attack of elevated temperature, cleaning agent, ultrasonic treatment and mechanical stress (from pressurised water) may result in damage to the paint. Please mark in the health and safety clearance form if you wish a repaint at your expense just in case such a damage should occur. We will also replace parts for cosmetic reasons at your request and at your expense.

Before returning the device

Pack the device properly, if necessary, please order original packaging materials at your costs. Mark the package completely



Enclose the completed [health and safety clearance form](#).

Notify the carrier of any possible contamination if required.

Scrapping and waste disposal

Dispose of the equipment and any components removed from it safely in accordance with all local and national safety and environmental requirements. Particular care must be taken with components and waste oil which have been contaminated with dangerous substances from your processes. Do not incinerate fluoroelastomer seals and O-rings. You may authorize us to dispose of the equipment **at your expense**. Otherwise we return the device at your expense.

Warranty

VACUUBRAND shall be liable for insuring that this product, including any agreed installation, has been free of defects at the time of the transfer of risk.

VACUUBRAND shall not be liable for the consequences of improper handling, use, servicing or operation of this product or the consequences of normal wear and tear of wearing parts such as diaphragms, seals, valves, vanes, condensers, oil and the breakage of glass or ceramic parts, for the consequences of chemical, electrochemical or electrical influences or the failure to follow the instructions in this manual.

Claims for defects against VACUUBRAND shall be limited to one year from delivery. The same shall apply to claims for damages irrespective of legal grounds.

For further information on general terms and conditions refer to www.vacuubrand.com.

EG-Konformitätserklärung für Maschinen
EC Declaration of Conformity of the Machinery
Déclaration CE de conformité des machines



Hersteller / Manufacturer / Fabricant:

VACUUBRAND GMBH + CO KG · Alfred-Zippe-Str. 4 · 97877 Wertheim · Germany

Hiermit erklärt der Hersteller, dass das Gerät konform ist mit den Bestimmungen der Richtlinien:

Hereby the manufacturer declares that the device is in conformity with the directives:

Par la présente, le fabricant déclare, que le dispositif est conforme aux directives:

- 2006/42/EG
- 2014/34/EU
- 2011/65/EU, 2015/863

Membranvakuumpumpe / Diaphragm vacuum pump / Pompe à membrane:

Typ / Type / Type: **ME 2 NT / ME 4 NT / ME 4S NT / MZ 2 NT / MZ 2D NT / MZ 2S NT / ME 8 NT / ME 8S NT / MD 4 NT / MD 4S NT / MD 4CRL NT / MV 2 NT**

Artikelnummer / Order number / Numéro d'article: **20730000, 20730002 / 20731000, 20731001, 20731002, 20731005 / 22613951 / 20732000, 20732001, 20732002, 20732005 / 20732200, 20732202, 20732205 / 20732100, 20732105 / 20734000, 20734001, 20734002 / 20734100 / 20736000, 20736001, 20736002, 20736005, 20736006 / 20736105 / 20736445 / 20738000, 20738001, 20738002**

Seriennummer / Serial number / Numéro de série: Siehe Typenschild / See rating plate / Voir plaque signalétique

Angewandte harmonisierte Normen / Harmonized standards applied / Normes harmonisées utilisées:

DIN EN ISO 12100:2011, DIN EN 1012-2:2011, DIN EN 61010-1:2020,

IEC 61010-1:2010 + COR:2011 + A1:2016, modifiziert / modified / modifié + A1:2016/COR1:2019

DIN EN 1127-1:2019; DIN EN ISO 80079-36:2016

DIN EN IEC 63000:2019

Bevollmächtigter für die Zusammenstellung der technischen Unterlagen / Person authorised to compile the technical file / Personne autorisée à constituer le dossier technique:

Dr. Constantin Schöler · VACUUBRAND GMBH + CO KG · Germany

Ort, Datum / place, date / lieu, date: Wertheim, 09.01.2023

(Dr. Constantin Schöler)

Geschäftsführer / Managing Director / Gérant

ppa.

*Technischer Leiter / Technical Director /
Directeur technique*

VACUUBRAND GMBH + CO KG

Alfred-Zippe-Str. 4
97877 Wertheim

Tel.: +49 9342 808-0

Fax: +49 9342 808-5555

E-Mail: info@vacuubrand.com

Web: www.vacuubrand.com

EG-Konformitätserklärung für Maschinen
EC Declaration of Conformity of the Machinery
Déclaration CE de conformité des machines



Hersteller / Manufacturer / Fabricant:

VACUUBRAND GMBH + CO KG · Alfred-Zippe-Str. 4 · 97877 Wertheim · Germany

Hiermit erklärt der Hersteller, dass das Gerät konform ist mit den Bestimmungen der Richtlinien:

Hereby the manufacturer declares that the device is in conformity with the directives:

Par la présente, le fabricant déclare, que le dispositif est conforme aux directives:

- 2006/42/EG
- 2011/65/EU, 2015/863

Membranvakuumpumpe / Diaphragm vacuum pump / Pompe à membrane:

Typ / Type / Type: **ME 4R NT**

Artikelnummer / Order number / Numéro d'article: **20731100, 20731102, 22614134**

Seriennummer / Serial number / Numéro de série: Siehe Typenschild / See rating plate / Voir plaque signalétique

Angewandte harmonisierte Normen / Harmonized standards applied / Normes harmonisées utilisées:

DIN EN ISO 12100:2011, DIN EN 1012-2:2011, DIN EN 61010-1:2020,

IEC 61010-1:2010 + COR:2011 + A1:2016, modifiziert / modified / modifié + A1:2016/COR1:2019

DIN EN IEC 63000:2019

Bevollmächtigter für die Zusammenstellung der technischen Unterlagen / Person authorised to compile the technical file / Personne autorisée à constituer le dossier technique:

Dr. Constantin Schöler · VACUUBRAND GMBH + CO KG · Germany

Ort, Datum / place, date / lieu, date: Wertheim, 09.01.2023

(Dr. Constantin Schöler)

Geschäftsführer / Managing Director / Gérant

ppa.

(Jens Haibel)

*Technischer Leiter / Technical Director /
Directeur technique*

VACUUBRAND GMBH + CO KG

Alfred-Zippe-Str. 4
97877 Wertheim

Tel.: +49 9342 808-0

Fax: +49 9342 808-5555

E-Mail: info@vacuubrand.com

Web: www.vacuubrand.com

Declaration of Conformity



Manufacturer:

VACUUBRAND GMBH + CO KG · Alfred-Zippe-Str. 4 · 97877 Wertheim · Germany

Hereby the manufacturer declares that the device is in conformity with the directives:

- Supply of Machinery (Safety) Regulations 2008 (S.I. 2008 No. 1597, as amended by S.I. 2019 No. 696)
- The Equipment and Protective Systems Intended for Use in Potentially Explosive Atmospheres Regulations 2016 (S.I. 2016 No. 1107, as amended by S.I. 2019 No. 696)
- The Restriction of the Use of Certain Hazardous Substances in Electrical and Electronic Equipment Regulations 2012 (S.I. 2012 No. 3032)

Diaphragm vacuum pump

Type: **ME 2 NT / ME 4 NT / ME 4S NT / MZ 2 NT / MZ 2D NT / MZ 2S NT / ME 8 NT / ME 8S NT / MD 4 NT / MD 4S NT / MD 4CRL NT / MV 2 NT**

Order number: **20730000, 20730002 / 20731000, 20731001, 20731002, 20731005 / 22613951 / 20732000, 20732001, 20732002, 20732005 / 20732200, 20732202, 20732205 / 20732100, 20732105 / 20734000, 20734001, 20734002 / 20734100 / 20736000, 20736001, 20736002, 20736005, 20736006 / 20736105 / 20736445 / 20738000, 20738001, 20738002**

Serial number: See rating plate

Designated standards applied:

EN ISO 12100:2010, EN 1012-2:1996+A1:2009, EN 61010-1:2010+A1:2019, EN 61010-1:2010/A1:2019/AC:2019-04
EN 1127-1:2019, EN ISO 80079-36:2016
EN IEC 63000:2018

Person authorised to compile the technical file:

Dr. Constantin Schöler · VACUUBRAND GMBH + CO KG · Germany

Place, date: Wertheim, 09.01.2023

(Dr. Constantin Schöler)

Managing Director

ppa.

Technical Director

VACUUBRAND GMBH + CO KG

Alfred-Zippe-Str. 4
97877 Wertheim

Tel.: +49 9342 808-0
Fax: +49 9342 808-5555
E-Mail: info@vacuubrand.com
Web: www.vacuubrand.com

Declaration of Conformity



Manufacturer:

VACUUBRAND GMBH + CO KG · Alfred-Zippe-Str. 4 · 97877 Wertheim · Germany

Hereby the manufacturer declares that the device is in conformity with the directives:

- Supply of Machinery (Safety) Regulations 2008 (S.I. 2008 No. 1597, as amended by S.I. 2019 No. 696)
- The Restriction of the Use of Certain Hazardous Substances in Electrical and Electronic Equipment Regulations 2012 (S.I. 2012 No. 3032)

Diaphragm vacuum pump

Type: **ME 4R NT**

Order number: **20731100, 20731102, 22614134**

Serial number: See rating plate

Designated standards applied:

EN ISO 12100:2010, EN 1012-2:1996+A1:2009, EN 61010-1:2010+A1:2019, EN 61010-1:2010/A1:2019/AC:2019-04
EN IEC 63000:2018

Person authorised to compile the technical file:

Dr. Constantin Schöler · VACUUBRAND GMBH + CO KG · Germany

Place, date: Wertheim, 09.01.2023

(Dr. Constantin Schöler)

Managing Director

ppa.

(Jens Kaibel)

Technical Director

VACUUBRAND GMBH + CO KG

Alfred-Zippe-Str. 4
97877 Wertheim

Tel.: +49 9342 808-0
Fax: +49 9342 808-5555
E-Mail: info@vacuubrand.com
Web: www.vacuubrand.com

Certificate



Certificate no.

CU 72225884 01

License Holder:
 VACUUBRAND GMBH + CO KG
 Alfred-Zippe-Str. 4
 97877 Wertheim
 Deutschland

Manufacturing Plant:
 VACUUBRAND GMBH + CO KG
 Alfred-Zippe-Str. 4
 97877 Wertheim
 Deutschland

Test report no.: USA- DE22ZTJM 001

Client Reference: Agnes Wollschläger

Tested to: UL 61010-1:2012 R7.19

CAN/CSA-C22.2 NO. 61010-1-12/ + GI1 + GI2 (R2017) + A1

Certified Product: Vacuum Pumps for Laboratory Use

License Fee - Units

Model : Mw xyyy NT yy z; PC 101 NT; PC 201 NT
 Designation (w=E,Z,D,V; x=2,4,6,8; y=A-Z or blank;
 z=+AK, +EK, +2AK, +AK+EK, +AK+EK TE, +IK+EK,
 +AK SYNCHRO+EK, +AK+M+D or blank)
 Input ratings : 100-115V 50/60Hz 3.4A / 120V 60Hz 3.4A; or
 100-115V 50/60Hz 5.7A / 120V 60Hz 5.7A; or
 120V 60Hz 4,0A; or 230V 50/60Hz 1.8A; or
 100#115V 50/60Hz 5.7A / 120V 60Hz 4.0A /
 200#230V 50/60Hz 3.0A; or 230V 50/60Hz 3.0A; or
 100#115V 50/60Hz 3.4A / 120V 60Hz 2.9A /
 200#230V 50/60Hz 1.8A
 Protection: Class I; IP 40/Type 1(UL50E)

7

7

Appendix: 1, 1-11

Licensed Test mark:



Date of Issue
 (day/mo/yr)
 02/12/2022

TUV Rheinland of North America, Inc., 12 Commerce Road, Newtown, CT 06470, Tel (203) 426-0888 Fax (203) 426-4009

This certificate is only valid for pumps with the respective mark (Licensed Test mark) on the pump rating plate.

DECLARATION OF CONFORMITY – China RoHS 2

VACUUBRAND GMBH + CO KG has made reasonable efforts to ensure that hazardous materials and substances may not be used in its products.

In order to determine the concentration of hazardous substances in all homogeneous materials of the subassemblies, a “Product Conformity Assessment” (PCA) procedure was performed. As defined in GB/T 26572 the “Maximum Concentration Value” limits (MCV) apply to these restricted substances:

- Lead (Pb): 0.1%
- Mercury (Hg): 0.1%
- Cadmium (Cd): 0.01%
- Hexavalent chromium (Cr(+VI)): 0.1%
- Polybrominated biphenyls (PBB): 0.1%
- Polybrominated diphenyl ether (PBDE): 0.1%

Environmentally Friendly Use Period (EFUP)

EFUP defines the period in years during which the hazardous substances contained in electrical and electronic products will not leak or mutate under normal operating conditions. During normal use by the user such electrical and electronic products will not result in serious environmental pollution, cause serious bodily injury or damage to the user’s assets. The Environmentally Friendly Use Period for VACUUBRAND products is 40 years.



MATERIAL CONTENT DECLARATION FOR VACUUBRAND PRODUCTS						
有毒有害物质或元素 Hazardous substances						
部件名称 Part name	铅 Pb	汞 Hg	镉 Cd	六价铬 Cr(+VI)	多溴联苯 PBB	多溴二苯醚 PBDE
包装 Packaging	0	0	0	0	0	0
塑料外壳 / 组件 Plastic housing / parts	0	0	0	0	0	0
真空油 Vacuum oil	0	0	0	0	0	0
电池 Battery	0	0	0	0	0	0
玻璃 Glass	X	0	0	0	0	0
电子电气组件 Electrical and electronic parts	X	0	0	0	0	0
控制器 / 测量设备 Controller / measuring device	X	0	0	0	0	0
金属外壳 / 组件 Metal housing / parts	X	0	0	0	0	0
电机 Motor	X	0	0	0	0	0
配件 Accessories	X	0	0	0	0	0
此表格是按照SJ/T 11364-2014中规定所制定的。 This table is created according to SJ/T 11364-2014.						

- O: 表示该有毒有害物质在该部件所有均质材料中的含量均在GB/T 26572规定的限量要求以下。
 O: Indicates that the above mentioned hazardous substance contained in all homogeneous materials of the part is below the required limit as defined in GB/T 26572.
- X: 表示该有毒有害物质至少在该部件某一均质材料中的含量超出GB/T 26572规定的限量要求。
 X: Indicates that the above mentioned hazardous substance contained in at least one of the homogeneous materials of this part is above the required limit as defined in GB/T 26572.

电池、玻璃器皿和配件可能不属于所附设备所包含的内容，它们可能有各自单独的EFUP标记和/或可能正在维护其部件EFUP标记的更新。

Batteries, glassware and accessories might not be content of the enclosed device and may have its own EFUP-marking and/or might be maintaining parts with changing EFUP-marking.

除上表所示信息外，还需声明的是，这些部件并非是有意图用铅（Pb）、汞（Hg）、镉（Cd）、六价铬（Cr(+VI)）、多溴联苯（PBB）或多溴二苯醚（PBDE）来制造的。

Apart from the disclosures in the above table, the subassemblies are not intentionally manufactured or formulated with lead (Pb), mercury (Hg), cadmium (Cd), hexavalent chromium (Cr+VI), polybrominated biphenyls (PBB), and polybrominated diphenyl ethers (PBDE).

Products manufactured by VACUUBRAND may enter into further devices (e.g., rotary evaporator) or can be used together with other appliances (e.g., usage as booster pumps).

With these products and appliances in particular, please note the EFUP labeled on these products. VACUUBRAND will not take responsibility for the EFUP of those products and appliances.

Place, date: Wertheim, 06 September 2022



(Dr. Constantin Schöler)
 Managing Director



ppa. (Jens Kaibel)
 Technical Director

VACUUBRAND GMBH + CO KG

Alfred-Zippe-Str. 4
 97877 Wertheim
 Germany

Tel.: +49 9342 808-0
 Fax: +49 9342 808-5555
 E-Mail: info@vacuubrand.com
 Web: www.vacuubrand.com

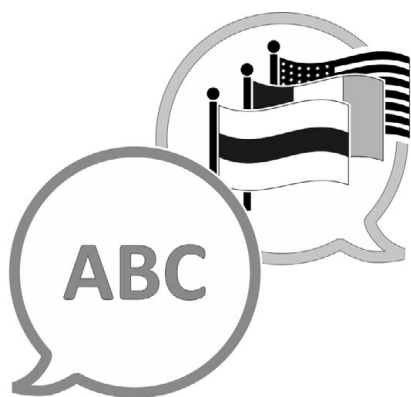
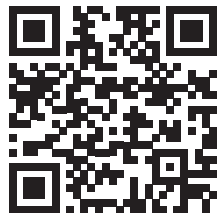

[VACUUBRAND > Support > Manuals](#)

Manufacturer:

VACUUBRAND GMBH + CO KG
Alfred-Zippe-Str. 4
97877 Wertheim
GERMANY

Phone:

Head office +49 9342 808-0
Sales +49 9342 808-5550
Service +49 9342 808-5660

Fax: +49 9342 808-5555

Email: info@vacuubrand.com

Web: www.vacuubrand.com