

# CHEMISTRY-HYBRID-PUMP

RC 6

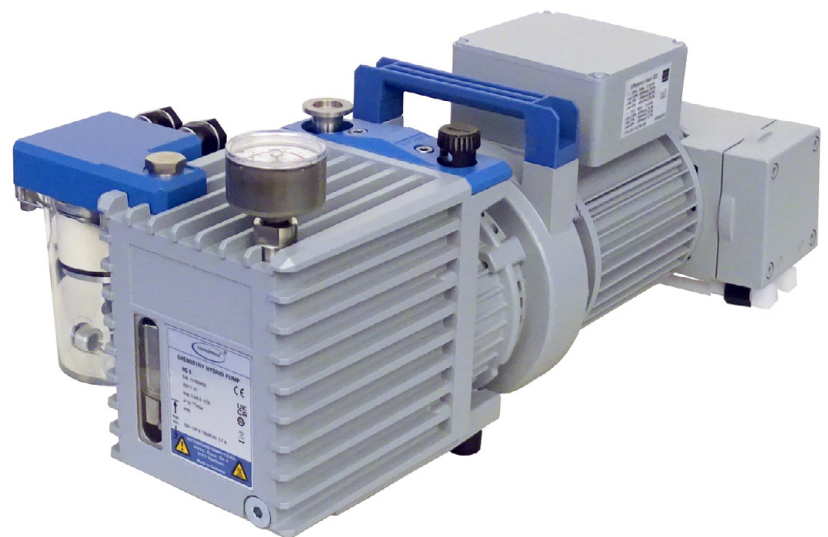

## Instructions for use



Dear customer,

Your VACUUBRAND pumps are designed to provide you with many years of trouble-free service with optimal performance. Through our long experience in design, construction and operation of vacuum pumps, combined with the latest developments in material and manufacturing technology, we have accumulated a wealth of application and safety insights that we want to share with you.

Please read these instructions for use before the initial operation of your pump.

Our quality maxim is the "zero fault principle":

Every pump, before leaving our factory, is tested intensively, including an endurance run of 32 hours. Any faults, even those which occur rarely, are identified and can be eliminated immediately.

After completion of the endurance run, every pump is tested, and must achieve specifications before shipment.

We are committed to providing our customers only pumps that meet this high quality standard.

While our pumps cannot eliminate all of your work, we design, manufacture and test them to ensure that they will be an effective and trouble-free tool to assist you in that work.

Yours,

VACUUBRAND GMBH + CO KG

### **After sales service:**

**Contact your local dealer or call +49 9342 808-5500.**

### **Trademark index:**

VACUU·LAN® (US-Reg.No 3,704,401), VACUU·BUS®, VACUU·CONTROL®, VACUU·SELECT® (US-Reg.No 5,522,260), VARIO® (US-Reg.No 3,833,788), VACUUBRAND® (US-Reg.No 3,733,388), VACUU·VIEW®, GREEN VAC® (US-Reg.No. 4,924,553), VACUU·PURE® (US-Reg.No. 5,559,614) and also the shown company logos are registered trademarks of VACUUBRAND GMBH + CO KG in Germany and/or other countries.

# Contents



<b>Safety information!</b> .....	<b>5</b>
Important information! .....	5
General information .....	7
Intended use.....	8
Improper use .....	9
Foreseeable misuse .....	10
Setting up and installing the equipment .....	11
Ambient conditions .....	13
Operating conditions .....	14
Safety during operation .....	15
Maintenance and repair.....	19
<b>Technical data</b> .....	<b>22</b>
Gas inlet temperatures .....	24
Wetted parts .....	24
Abbreviations.....	24
Pump parts .....	25
Replacing the device fuses (120 version only).....	28
<b>Use and operation</b> .....	<b>29</b>
Unpacking .....	29
Initial operation / Pouring in the pump oil .....	30
Installing a pump in a vacuum system .....	31
During operation.....	33
Important notes regarding the use of gas ballast .....	37
Operating the pump with condensate in the catchpots .....	38
Pumping chemically aggressive or toxic gases and vapors .....	39
Shutdown .....	40
<b>Oil change</b> .....	<b>41</b>
Oil change procedure .....	42
Notes on the pump oil .....	44
<b>Accessories</b> .....	<b>45</b>
<b>Troubleshooting</b> .....	<b>47</b>
<b>Replacing diaphragms and valves</b> .....	<b>50</b>
Cleaning and inspecting the diaphragm pump heads .....	52
Replacing the diaphragm .....	54
Assembling the pump heads .....	56
Assembling the connecting hose.....	57
Checking the operability of the diaphragm pump .....	58

Replacing the filter element in the oil mist filter .....	59
Inspecting the safety pop valve .....	59
<b>Repair - Maintenance - Return - Calibration.....</b>	<b>60</b>
<b>Warranty .....</b>	<b>62</b>
<b>Declarations and certificates.....</b>	<b>63</b>

# Safety information!

## *Important information!*

### **WARNING**

-  **Keep this manual complete and accessible to personnel at all times!**
-  **Read this manual carefully before installing or operating the equipment. Observe the instructions contained in this manual.**
-  **Do not modify the equipment without authorization.**

### **NOTICE**

This manual is an integral part of the equipment described therein. It describes the safe and proper use of the vacuum pump.

**Make operating personnel aware of dangers arising from the pump and the pumped substances.**

**VACUUBRAND disclaims any liability for inappropriate use of these pumps and for damage from failure to follow instructions contained in this manual.**

This manual is only to be used and distributed in its complete and original form. It is strictly the users' responsibility to check carefully the validity of this manual with respect to his product.

Manual-no.: 20901388

**The document "Safety information for vacuum equipment" is part of this manual! Read the "Safety information for vacuum equipment" and observe the instructions contained therein!**

**The following signal word panels and safety symbols are used throughout this manual:**



This is the safety alert symbol. It is used to alert you to potential personal injury hazards. Obey all safety messages that follow this symbol to avoid possible injury and death.



➔ DANGER indicates a hazardous situation which, if not avoided, will result in death or serious injury.



☞ WARNING indicates a hazardous situation which, if not avoided, could result in death or serious injury.



• CAUTION indicates a hazardous situation which, if not avoided, could result in minor or moderate injury.



NOTICE is used to address practices not related to personal injury.



Caution! Hot surface!



Caution! Electrical voltage!



Disconnect equipment from AC power.



Electronic components must not be disposed of in the domestic waste at the end of their service life. Used electronic devices contain harmful substances that can cause damage to the environment or human health. End users are legally obliged to take used electric and electronic devices to a licensed collection point.

### Formatting used in this manual:

**Note:** The signal word panels in all sections of this manual always refer to all paragraphs of the same format (➔ / ☞ / • / plain text) following each signal word panel.

## General information

### NOTICE

Remove all packing material from the packing box. Carefully lift the vacuum pump out of the packaging and retain all packaging until the equipment is inspected and tested. Observe the notes on unpacking, see section “Initial operation / Pouring in the pump oil”, pg. 30. Remove the protective caps from the inlet and outlet ports and retain for future use. Inspect the equipment promptly and carefully.

If the equipment is damaged, notify the supplier and the carrier in writing within three days. Retain all packing material for inspection. State the item number of the product together with the order number and the supplier’s invoice number. Failure to check and give notice of damage will void any and all warranty claims for those deficiencies. Replace the protective caps, if the equipment is not used immediately. Store the equipment in dry and non-corrosive conditions (see also “Technical data”, pg. 22).

### ⚠ WARNING

👉 **Do not use any damaged equipment.**

### ⚠ CAUTION

- Check the pump’s oil level.
- The pump is delivered without oil filling. **Fill with oil before operating the pump**, see section “Use and operation”, pg. 29.
- Aging of the oil (as indicated by darker color compared to new oil, strange odor of the oil, particles in the oil, or contamination) necessitates an oil change.
- Use the handle when moving the pump. Note that the weight of the vacuum pump is approx. 25 kg.

## ***Intended use***

The RC 6 is a combination of an oil-sealed rotary vane pump and a chemistry diaphragm pump for improved corrosion resistance for the fine vacuum range in the laboratory. The diaphragm pump permanently evacuates the oil reservoir of the rotary vane pump, freeing it from corrosive gases and vapors.

The vacuum pump may only be used indoors in a dry, non-explosive atmosphere.

### **Intended use also includes:**

- ☞ Observing the information in the document Safety information for vacuum equipment.
- ☞ Observing the manual.
- ☞ Complying with all notes on correct vacuum and electrical connections; see section “Use and operation”, pg. 29.
- ☞ Observing the manual of connected components.
- ☞ Regularly inspecting the vacuum pump according to its operating conditions and have this carried out by qualified personnel.
- ☞ Using only original VACUUBRAND parts and original accessories / approved accessories or spare parts.
- ☞ The pumps are designed for **ambient temperatures** during operation between +54°F and +104°F (+12°C and +40°C). Periodically check maximum temperatures if installing the pump in a cabinet or a housing. Make sure ventilation is adequate to maintain recommended operating temperature. Install an external automatic ventilation system if necessary. If pumping hot process gases, make sure that the maximum permitted gas inlet temperature is not exceeded. The maximum permitted gas inlet temperature depends on several parameters like inlet pressure and ambient temperature (see “Technical data”, pg. 22).

Any other use is considered improper use.



## ***Improper use***

Incorrect use or any application which does not correspond to the technical data may result in injury or damage to property.

### **Improper use includes:**

- ☞ Using the product contrary to its intended use,
- ☞ Using the product in non-commercial environments, unless the necessary protective measures and precautions have been taken by the company,
- ☞ Operation under inadmissible environmental and operating conditions,
- ☞ Operation despite obvious errors or defective safety devices,
- ☞ Unauthorized extensions, conversions, or repairs, in particular when these impair safety,
- ☞ The use of unauthorized accessories or spare parts,
- ☞ Usage despite incomplete assembly,
- ☞ operation by insufficiently trained or qualified personnel,
- ☞ Switching on/off with tools or one's foot,
- ☞ Operation with sharp-edged objects,
- ☞ Pulling plug-in connections on the cable out of the socket,
- ☞ Extracting or conveying solids or liquids.

- ☞ Ensure that the individual components are only connected, combined and operated according to their design and as indicated in the instructions for use.

Use only **original manufacturer's spare parts and accessories**. Otherwise the safety and performance of the equipment, as well as the electromagnetic compatibility of the equipment might be reduced.

The CE mark may be voided if not using original manufacturer's spare parts.

- ☞ Do not use the pump to generate pressure.
- ☞ Particles and dust must not enter the pump.

☞ Do not pump liquids.

## ⚠ CAUTION

- Ensure that the pump is chemically resistant to the pumped substances prior to operation.

## NOTICE

Use the equipment **only as intended**, that is, for generation of vacuum in vessels designed for that purpose. Any other use will automatically invalidate all warranty and liability claims. Remain aware of safety and risks.

### ***Foreseeable misuse***

In addition to improper use, there are types of use which are prohibited when handling the pump:

#### **Prohibited types of use include, in particular:**

- ☞ use on humans or animals,
- ☞ installation and operation in potentially explosive atmospheres,
- ☞ use in mines or underground,
- ☞ using the product to generate pressure,
- ☞ using the product with closed pump outlet,
- ☞ fully exposing vacuum equipment to the vacuum,
- ☞ immersing vacuum equipment in liquids, or exposing it to water spray or steam jets,
- ☞ pumping oxidizing and pyrophoric substances, liquids or solids,
- ☞ pumping hot, unstable, or explosive media,
- ☞ pumping substances which may react explosively under impact and/or elevated temperature without an air supply.

## ***Setting up and installing the equipment***

### **! DANGER**

➔ Equipment must be connected only to a **suitable electrical supply** and a suitable ground point. As such, the plug must be plugged into an outlet that is properly grounded. Failure to connect the motor to ground may result in deadly electrical shock.

The supply cable may be fitted with a molded European IEC plug or a plug suitable for your local electrical supply. The cable contains wires color coded as follows: green or green and yellow: ground; blue or white: neutral; brown or black: hot.

### **! WARNING**

☞ Due to the high compression ratio, the pump may generate overpressure at the outlet. Check pressure compatibility with system components (e.g., exhaust pipeline) at the outlet.

☞ Do not permit any **uncontrolled pressurizing**. Make sure that the exhaust tubing cannot become blocked. If there is an exhaust isolation valve, make sure that you cannot operate the equipment with the valve closed.

☞ Keep the electrical power cord away from heated surfaces.

☞ Keep the electrical power cord away from hot surfaces.

### **! CAUTION**

- Provide a firm, level platform for the equipment. Check that the system which you are going to evacuate is mechanically stable. Check that all fittings are secure. Ensure a stable position of the pump without any mechanical contact other than the pump feet.

- Do not operate the pump with closed outlet. Closing the outlet during operation may cause damage to pump or components next in line.

- Comply with **maximum permissible pressures** at inlet and outlet and with **maximum permissible pressure differences** between inlet and outlet. See section “Technical data”, pg. 22. Do not operate the pump with overpressure at the inlet.

- Avoid overpressure of more than 17.5 psi absolute (1.2 bar absolute) in the event that gas or inert gas is connected to the pump, to the gas ballast or to a venting valve.
- **Note:** Flexible elements will shrink when evacuated.
- Connect hoses gas tight at inlet and outlet of the pump.
- Ensure that no foreign objects can be drawn into the pump.



- Risk of burns from hot surfaces.  
In case of failure the pump surface can heat up to temperatures  $> 105\text{ }^{\circ}\text{C}$ . Provide a suitable contact guard to protect yourself from accidental contact with hot surfaces.  
Ensure the cooling-down of the pump prior to any further work. Wear adequate personal protective equipment, if necessary.
- Check the power source and the pump's rating plate to be sure that the power source and the equipment match in voltage, phase, and frequency.
- Use only oil of the recommended type. Other oils or operating fluids may cause damage of the pump or danger.
- Take adequate precautions when handling pump fluids, lubricants, and solvents. Use appropriate protective clothing, safety goggles and protective gloves to avoid excessive contact with the skin and possible skin irritations (including dermatitis). Do not inhale or swallow! Ensure that the pump location is well ventilated and that possible toxic effects of certain vapors are avoided. Maintain adequate levels of hygiene and cleanliness.
- Comply with all relevant statutory requirements and regulations concerning the handling, storage and disposal of oil.

**Note:** Do not allow oils to enter the drainage system or other bodies of water. Spillage can cause accidents (slip hazard)!

## **NOTICE**

Make sure ventilation is adequate to maintain recommended operating temperature. Keep a minimum distance of 2 in (5 cm) between the cooling fan and surrounding items (e.g., housing, walls, etc.), or else install an external automatic ventilation system. Check fan regularly for dust/dirt. Clean fan guard if necessary to avoid a reduction of ventilation.

The mains plug is a disconnecting device to separate the pump from the supply voltage. Ensure that the mains plug is easily accessible at all times to allow the separation of the device from the power supply.

The On/Off switch is located at the rear of the terminal box.

Use only hoses at the inlet and outlet of the pump with an inner diameter at least as large as the diameter of the pump's connections (to avoid overpressure at the outlet, and reduction of pumping speed at the inlet).

Allow the equipment to equilibrate to ambient temperature if you bring it from cold environment into a room prior to operation. Notice if there is water condensation on cold surfaces.

Comply with all **applicable and relevant safety requirements** (regulations and guidelines). **Implement the required actions and adopt suitable safety measures.**

## ***Ambient conditions***

### **! DANGER**

➔ Do not reach for this product if it has fallen into liquid. There is a risk of deadly electrical shock. Unplug the system immediately.

**WARNING**

- ☞ Do not use this product in an area where it can fall or be pulled into water or other liquids.

**CAUTION**

- This product may only be used indoors in a non-explosive atmosphere, and in a dry environment. Adopt suitable measures in case of differences from recommended conditions, e.g., installation in higher altitudes (risk of insufficient cooling), conductive pollution or external condensation on the pump.
- Do not operate this product near flames.

**NOTICE**

To the best of our knowledge the equipment is in compliance with the requirements of the applicable EC-directives and harmonized standards (see "Declaration of Conformity") with regard to design, type and model. Directive EN 61010-1 gives in detail the conditions under which the equipment can be operated safely (see also IP degree of protection, "Technical data", pg. 22).

***Operating conditions*****DANGER**

- ➔ These pumps are not approved for operation in potentially explosive atmospheres. **Do not operate the pumps in potentially explosive atmospheres.**
- ➔ These pumps are not approved for the pumping of potentially explosive atmospheres. **Do not pump potentially explosive atmospheres.**
- ➔ The pumps are **not suitable** to pump any of the substances listed below.

**Do not pump:**

- **unstable substances**
- substances which react explosively under **impact** (mechanical stress) without air
- substances which react explosively when being exposed to **elevated temperatures** without air,
- **self inflammable** substances,
- substances which are **inflammable without air**
- **explosive substances.**

- ➔ The pumps are **not approved** for operation below ground. **Do not operate** the pump **below ground**.

## CAUTION

- **Do not pump** substances which may form **deposits** inside the pump. The pumps are not suitable for pumping substances which may form deposits inside the pump. Deposits and condensate in the pump may lead to increased temperatures even to the point of exceeding the maximum permitted temperatures. Deposits may cause seizing of the pump unit.
- Check the inlet and outlet of the pump and its oil condition, if there is a danger of forming **deposits** inside the pump, e.g., in the pump unit of the rotary vane pump or in the pump chamber of the diaphragm pump. Inspect the pump regularly and clean if necessary.
- Install a cold trap in front of the pump if pumping aggressive or corrosive gases or vapors.
- **Consider interactions and chemical reactions of the pumped media.** Ensure that the materials of the pump's wetted parts are compatible with the pumped substances, see section "Technical data", pg. 22. When changing the substances pumped, we recommend purging the pump with air or inert gas prior to changing the pumped media. Purging the pump will pump out residues and it will reduce the possibility of reactions of the pumped substances with each other and with the pump's materials.

## ***Safety during operation***

## DANGER

- ➔ Adopt suitable measures to prevent the release of dangerous, toxic, explosive, corrosive, noxious or polluting fluids, vapors and gases. To prevent any emission of such substances from the pump outlet, install an appropriate collecting and disposal system and take protective action for pump and environment.

- ➔ Drain and dispose of appropriately potentially dangerous gases and vapors at the outlet of the pump.
- ➔ You must take suitable precautions to prevent any formation of explosive mixtures in the expansion chamber, in the oil reservoir, in the pump chamber of the diaphragm pump, or at the outlet of the pump. In case, e.g., of a diaphragm failure, mechanically generated sparks, hot surfaces or static electricity may ignite these mixtures. Use inert gas for gas ballast or venting, if necessary.
- ➔ Drain appropriately or otherwise remove any potentially explosive mixtures at the outlet of the pump, or dilute them to non-explosive concentrations.
- ➔ Never operate this pump if it has a damaged cord or plug.

 **WARNING**

- ☞ If the pump is not working properly, has been dropped or has fallen into water, contact your pump service provider.
- ☞ Prevent any part of the human body from coming into contact with vacuum.
- ☞ Always provide a free and pressureless exhaust outlet. Make sure that the exhaust tubing cannot become blocked. Do not exceed an pressure of 16 psi (1.1 bar) in the exhaust tubing.
- ☞ Comply with applicable regulations when disposing of chemicals. Take into consideration that chemicals may be contaminated. Take adequate precautions to protect people from the effects of dangerous substances (chemicals, oil mist, thermal decomposition products of fluoroelastomers). Use appropriate protective clothing and safety goggles.



- ☞ Even if the pumped medium is only air or a pure gas, the discharge from rotary vane pumps will contain small quantities of oil vapor and petroleum fractions. These substances are particularly contaminating in closed spaces or in case of insufficient ventilation.

The discharge from the pump invariably contains the pumped gases or vapors! Connect a gas-tight exhaust line at the pump outlet if necessary. Always vent exhaust gases appropriately (e.g., into a fume hood).

Prevent any dangerous reactions with oil or oil vapors and the formation of impermissible or dangerous emissions.

- ☞ Failure of the pump (e.g., due to power interruption), failure of connected components or of parts of the supply, or a change of parameters must not be allowed to lead to a dangerous situation under any circumstances. In case of a leak in the manifold or at the shaft seal of the rotary vane pump, or in case of a diaphragm crack of the diaphragm pump, pumped substances might be released into the environment or into the pump housing or motor. Especially comply with notes on use and operation and maintenance.

- ☞ The residual **leak rate of the equipment** might render possible an exchange of gas, albeit extremely slight, between the environment and the vacuum system. Adopt suitable measures to prevent contamination of the pumped substances or the environment.

## CAUTION

- Ensure that no parts of your clothing, hair or fingers can be caught or drawn in at the inlet of the pump. Never insert fingers or drop any other object into the inlet or outlet.
- Check oil level of the rotary vane pump (through sight glass) every time before starting the pump.
- Check the pump's oil level and the condition of the oil on a regular basis.



- Pay attention to the safety symbol "hot surfaces" on the equipment. Depending on operation conditions and ambient conditions dangers due to hot surfaces may arise. Hot parts may cause burns if touched. Adopt suitable measures to prevent any danger arising from hot surfaces. Ensure that hot surfaces of the pump do not cause burns. Provide a suitable contact guard if necessary.
- Risk of burns from hot surfaces.  
In case of failure the pump surface can heat up to temperatures  $> 105\text{ }^{\circ}\text{C}$ . Provide a suitable contact guard to protect yourself from accidental contact with hot surfaces.  
Ensure the cooling-down of the pump prior to any further work. Wear adequate personal protective equipment, if necessary.
- A power failure or switching off the pump may cause accidental ventilation of the pump or the vacuum system, if the manual gas ballast valve of the rotary vane pump is open. If this constitutes a potential source of danger, take appropriate safety measures, e.g., install a solenoid operated gas ballast valve.
- The pump starts automatically when the power supply is switched off and then back on (e.g., after a power failure). Ensure that the automatic restart of the pump does not pose any danger to persons or equipment. Take appropriate safety precautions (e.g., shut-off valve, relay switch, protection against restart) if an automatic restart of the pump can lead to a dangerous situation.

**NOTICE**

Prevent the backpressure of gases and the backflow of condensates at the outlet.

Important notes on working with **condensable vapors**:

Allow the pump to attain its operating temperature before pumping condensable vapors. Keep the vapor inlet pressure below the permitted maximum (see "Technical data", pg. 22).

Open the gas ballast valve in case of pumping significant amounts of vapor.

Provide appropriate protective measures to allow for the possibility of failure and **malfunction**. The protective measures must also allow for the requirements of the respective application.

In case of overload, the motor is shut down by a **self-hold thermal cutout** in the winding.

**Note:** Only manual reset is possible. Switch off the pump and disconnect from the power source. Identify and eliminate the cause of failure. Wait approx. five minutes before restarting the pump.

## CAUTION

- **Note:** In case of **supply voltage below 115 V**, the lock of the cutout might be impaired and the pump may restart on its own after sufficient cooling down. Take appropriate precautions, if an automatic restart of the pump may lead to a dangerous situation (e.g., switch off the pump and disconnect from the power source).

## *Maintenance and repair*

### NOTICE

In order to comply with laws (occupational, health and safety regulations, safety at work law and regulations for environmental protection) vacuum pumps, components and measuring instruments can only be returned when certain procedures (see section "Repair - Maintenance - Return - Calibration", pg. 60", pg. 53) are followed.

Take advantage of our service seminars, which put special focus on the maintenance and repair of vacuum pumps.

For details and for the online "Instructions for repair" manual see [www.vacuubrand.com](http://www.vacuubrand.com).

In normal use, the lifetime of the diaphragms and valves is typically 15,000 operating hours. Bearings have a typical durability of 40000 h. Motor capacitors have a typical durability in the range of 10000 to 40000 h depending strongly on operation conditions, including ambient temperature, humidity or load.

 **DANGER**

➔ **Ensure that the pump cannot be operated accidentally. Never operate the pump if covers or other parts of the pump are disassembled.**



➔ **Switch off the pump. Disconnect the electrical power cord and wait five seconds** before starting maintenance to allow the capacitors to discharge.

➔ **Note:** The pump may be contaminated with process chemicals, which have been pumped during operation. Ensure that the pump is completely decontaminated before maintenance commences. Avoid the release of pollutants.

 **WARNING**

☞ Take adequate precautions to protect people from the effects (e.g., in case of inhalation or skin contact) of dangerous substances if contamination has occurred. Use appropriate protective clothing, safety goggles and protective gloves.

☞ **Wear parts have to be replaced regularly.**

☞ **Never operate a defective or damaged pump.**

☞ Check every motor capacitor regularly by measuring its capacity and estimating its time in operation. Replace old capacitors early enough to prevent a failure in operation. If an old motor capacitor fails, the capacitor may get hot. It may even melt or emit a flame, which could be **dangerous for persons and equipment in the vicinity**. The capacitors have to be replaced by an electrician.

- ☞ Vent the pump before starting maintenance. Isolate the pump and other components from the vacuum system. Allow sufficient cooling of the pump. Drain condensate, if applicable.

## **NOTICE**

Clean polluted surface with a clean, slightly moistened cloth. To moisten the cloth we recommend water or mild soap.

### **Interventions on the device**

- ☞ Work on the equipment may be performed only by a qualified person.
- ☞ Work on electrical equipment in particular may be performed only by qualified electricians.
- ☞ Ensure that maintenance is done only by suitably trained and supervised technicians or at least by an instructed person.

Ensure that the maintenance technician is familiar with the safety procedures which relate to the products processed by the pumping system.

# Technical data

Type		RC 6
Maximum pumping speed 50/60 Hz (ISO 21360)	cfm (m <sup>3</sup> /h)	3.5 / 4.1 (5.9 / 6.9)
Ultimate partial pressure without gas ballast <sup>a.)</sup>	Torr (mbar)	3*10 <sup>-4</sup> (4*10 <sup>-4</sup> )
Ultimate total pressure without gas ballast <sup>b.)</sup>	Torr (mbar)	1.5*10 <sup>-3</sup> (2*10 <sup>-3</sup> )
Ultimate total pressure with gas ballast	Torr (mbar)	0.75*10 <sup>-2</sup> (1*10 <sup>-2</sup> )
Water vapor tolerance <sup>c.)</sup>	Torr (mbar)	>>30 (>>40)
Oil capacity min./max.	quarts (ml)	0.36 / 0.53 (340 / 500)
Total pressure in oil reservoir <sup>d.)</sup>	Torr (mbar)	13.5 (18)
Oil temperature <sup>e.)</sup> (under typical operating conditions) approx.	°F (°C)	140 (60)
Recommended oil		VACUUBRAND B-oil
Maximum permissible inlet / outlet pressure (absolute)	psi (bar)	16 (1.1)
Maximum permissible pressure difference between inlet and outlet	psi (bar)	16 (1.1)
Maximum permissible pressure (absolute) at gas ballast valve	psi (bar)	17.5 (1.2)
Permissible ambient temperature storage / operation	°F (°C)	14 to 140 / 54 to 104 (-10 to +60 / +12 to +40)
Permissible relative atmospheric moisture during operation (no condensation)	%	30 to 85
Maximum permissible installation alti- tude above mean sea level	ft (m)	6500 (2000)
Rated motor power	hp (kW)	0.4 (0.30)
No-load speed 50/60 Hz	rpm	1500 / 1800
Maximum permissible range of supply voltage ( ±10% ) <b>Attention: Observe specifications of rating plate!</b>		230 V~ 50/60 Hz  100 – 120 V~ 50/60 Hz
Fuse, slow blow fuse (120 V version only)		2 x 10 AT 250 VAC, 5 x 20 mm, breaking capacity: 1000 A at 250 VAC
Starting current (120 V version only)		25 A for 100 ms

Type	RC 6	
Rated current during operation at: 230 V~ 50/60 Hz 100 – 120 V~ 50/60 Hz	A A	2.6 / 2.6 4.3 / 4.9
Motor protection	self-hold thermal cutout, manual reset <sup>f.)</sup>	
Overvoltage category	II	
Degree of protection IEC 60529	IP 40	
Pollution degree	2	
A-weighted emission sound pressure level <sup>g.)</sup> (uncertainty $K_{pA}$ : 3 dB(A))	dB(A)	50
Inlet	small flange KF DN 16 <sup>h.)</sup>	
Outlet	hose nozzle for tubing I.D. 3/8" (hose nozzle DN 10 mm)	
Dimensions L x W x H approx.	in (mm)	20.7 x 11.9 x 8.9 (526 x 302 x 226)
Weight with oil filling approx.	lbs. (kg)	55.1 (25.0)

- a.) Partial pressure of permanent gases measured at pump inlet.
- b.) The total pressure is higher than the partial pressure because the former includes the vapor pressure of the pump oil and other condensable vapors (e.g., water); the condition of the oil (cleanliness, content of hydrocarbons with higher partial pressures) is crucial for this value.
- c.) The maximum inlet pressure for water vapor, or rather the maximum inlet pressure for vapor, cannot be specified in accordance with ISO 21360-2 because it cannot be determined for the HYBRID pump in accordance with this standard. Because the diaphragm pump reduces the pressure in the oil-sealed part of the RC 6, however, the water vapor tolerance is considerably higher than that of a conventional oil-sealed rotary-vane pump.
- d.) With inlet sealed and without gas ballast.
- e.) Oil temperature and pressure in the oil reservoir are the relevant parameters for maximum vapor inlet pressure and chemical resistance.
- f.) In case of supply voltage below 115 V, the lock of the cutout might be restricted.
- g.) Measurement according to EN ISO 2151:2009 and EN ISO 3744:1995 at 230 V / 50 Hz and ultimate vacuum with exhaust tube at outlet.
- h.) **Pumps 22614824 and 22614825:** Additional adapter small flange KF DN 16 / hose nozzle DN 19 mm (material: aluminum) and adapter small flange KF DN 16 / hose nozzle 1/2" (material: PP)

## Gas inlet temperatures

Operating condition	Inlet pressure	Permitted range of gas temperatures at inlet
Continuous operation	> 75 Torr (100 mbar) (high gas load)	➔ 50 °F to 104 °F (+10°C to +40°C)
Continuous operation	< 75 Torr (100 mbar) (low gas load)	➔ 32 °F to 140 °F (0°C to +60°C)
Short-time (< 5 minutes)	< 75 Torr (100 mbar) (low gas load)	➔ 14 °F to 176 °F (-10°C to +80°C)

## Wetted parts

Components	Wetted materials
Metal parts	aluminum alloy, stainless steel, grey cast iron, steel (partly plasma nitrated), nickel-plated, zinc-plated
Plastic materials	epoxy resin, FFKM, FPM, NBR, PBT, PEEK, PFA, PMP, PPS glass-fiber reinforced, PTFE, PVC

**The pump RC 6 doesn't contain any nonferrous heavy metal.**

## Abbreviations

- FFKM:** Perfluoro elastomer
- FPM:** Fluoroelastomer
- NBR:** Nitrile butadiene rubber
- PBT:** Polybutylene terephthalate
- PEEK:** Polyether ether ketone
- PFA:** Perfluoroalkoxy
- PMP:** Polymethylpentene
- PPS:** Polyphenylene sulfide
- PTFE:** Polytetrafluoroethylene
- PVC:** Polyvinyl chloride

**We reserve the right for technical modification without prior notice!**



## ***Pump parts***

<b>Position</b>	<b>Component</b>
1	Outlet (OUT)
2	Inlet (IN)
3	Handle
4	Power connection
5	Oil mist filter
6	Oil inlet
7	Manometer for oil reservoir pressure control
8	Manual gas ballast valve
9	ON/OFF switch
10	Sight glass for oil level
11	Rating plate with min. / max. mark for oil level
12	Oil outlet / Oil drain plug
13	Fan / ventilation slots
14	Fuse

# RC 6 (230 V)

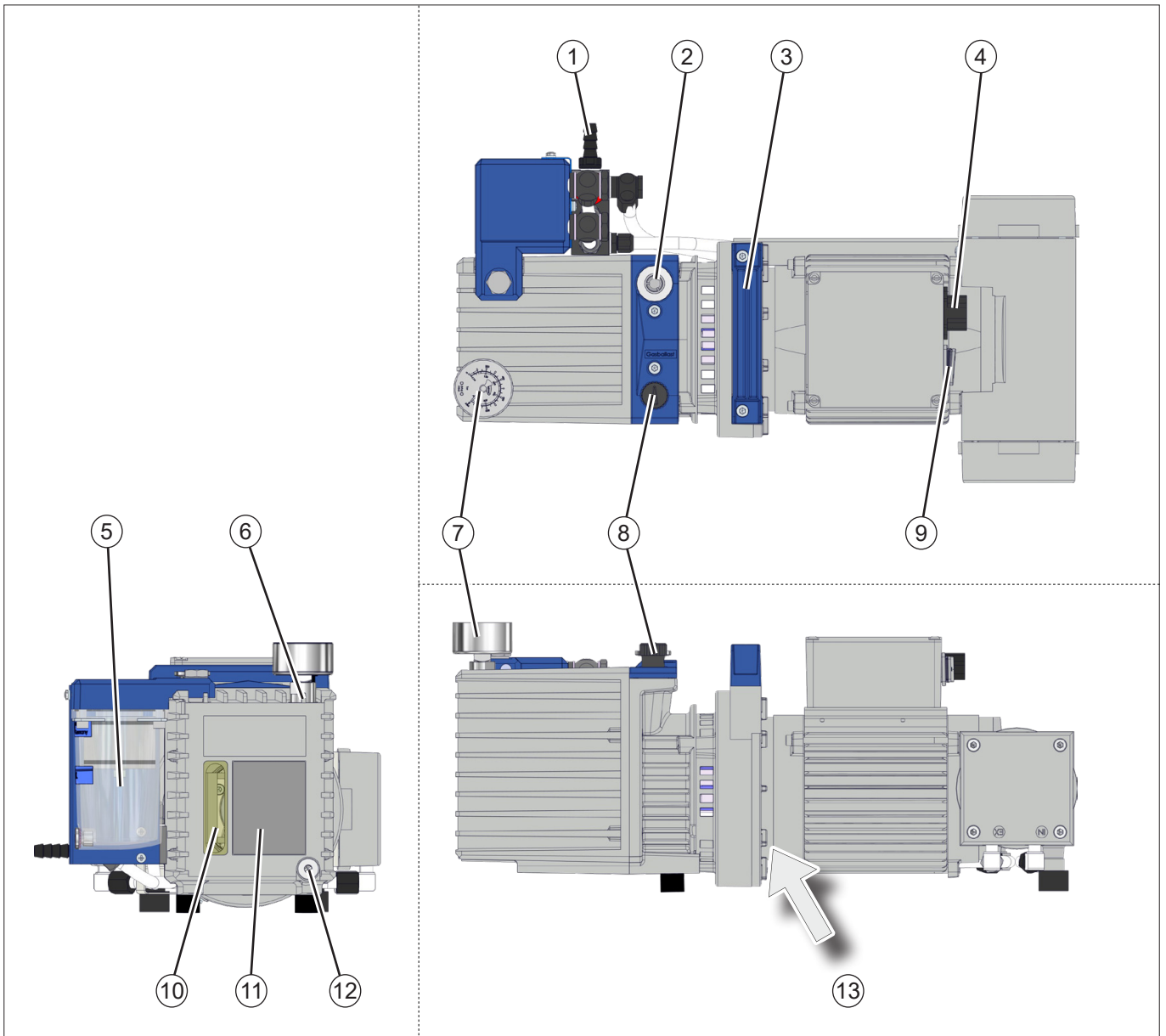

# RC 6 (120 V)

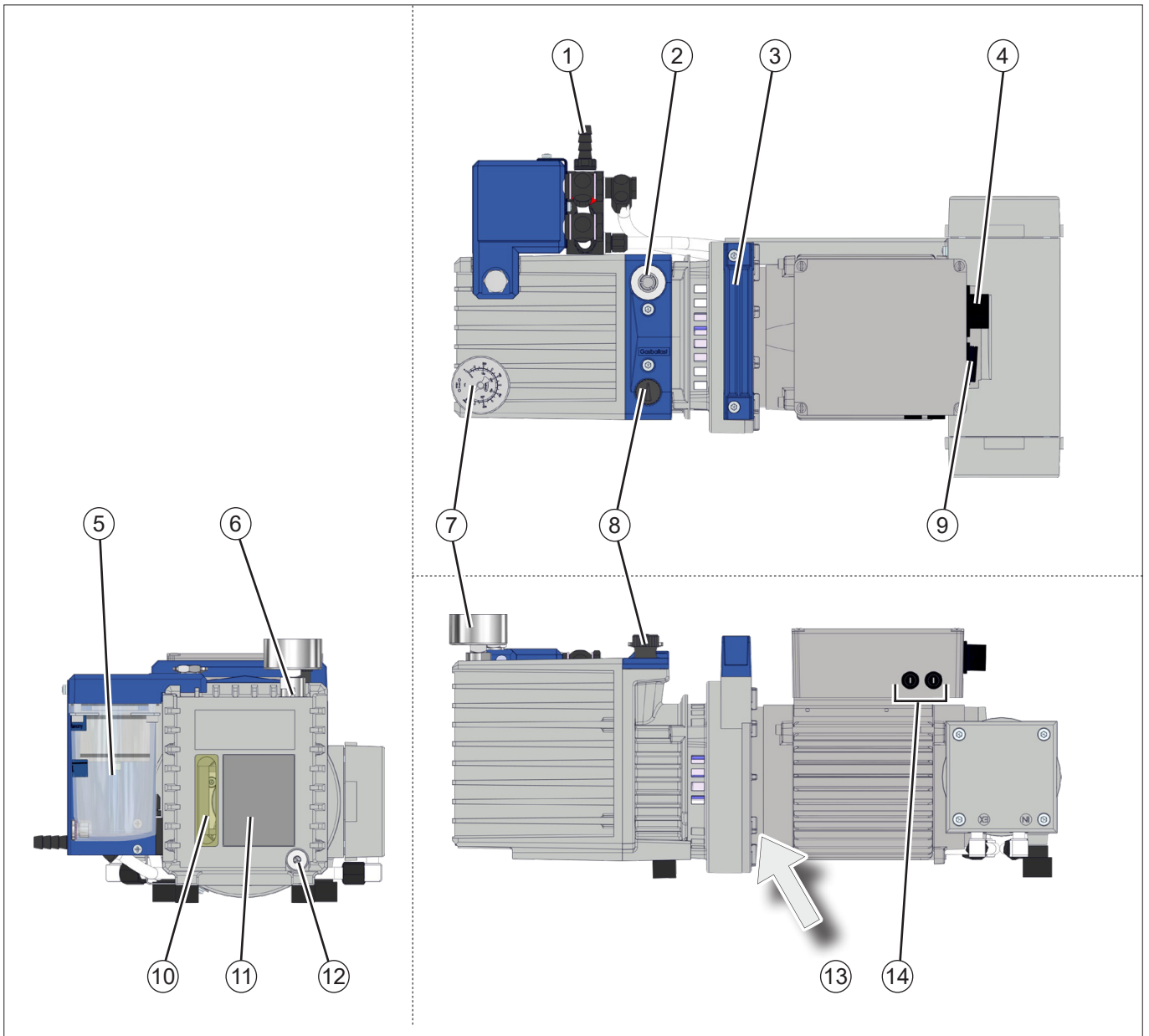

## Replacing the device fuses (120 version only)

**! DANGER**



➔ The pump has two fuses (double pole / neutral fusing) and might have live circuits, even when one fuse has blown or has been removed.

➔ **Switch off the pump.**



➔ **Disconnect the electrical power cord before unscrewing the fuse holder.**

Identify and eliminate the cause of failure before switching on the pump again.

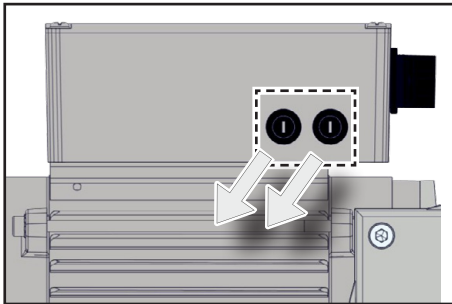

➔ Unscrew the fuse holder at the terminal box of the pump using a slotted screw driver.

➔ Replace the defective fuse by a fuse of the same type (see “Technical data”, pg. 22). Reassemble holder with fuse to the pump.

# Use and operation

## Method of operation:

The RC 6 is a four-stage vacuum pump consisting of an oil-sealed, two-stage rotary vane pump with a series-connected two-stage diaphragm pump. The two units are mounted on a common shaft and are connected directly to the drive motor. The dry-running compressor-type diaphragm pump evacuates the headspace of the oil reservoir of the rotary vane pump, thus considerably increasing the latter's maximum vapor inlet pressure and chemical resistance.

With the gas ballast valve closed, the rotary vane pump shuts off vacuum tight. This, in turn, prolongs the intervals between oil changes and improves corrosion resistance. The oil system incorporates an oil pump; this forced-lubrication system ensures an adequate supply of oil to the pump unit even at high inlet pressures. A mechanical retaining valve in the oil system prevents oil suck-back into the vacuum system.

The oil mist filter of the rotary vane pump removes 99 % of the oil mist. If an exhaust waste vapor condenser is fitted (available on request), the vapors handled by the pump can be condensed to a large extent and either be recycled or disposed of in accordance with regulations.

## Unpacking

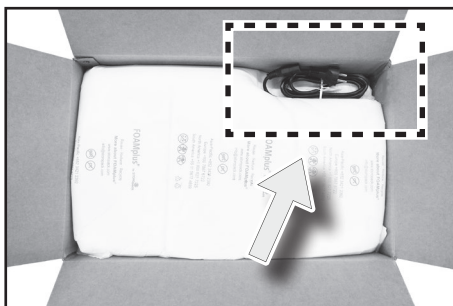

☞ Power cord.

➡ Remove the upper part of the foam packaging.

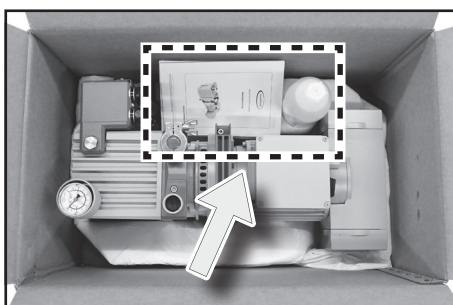

☞ Vacuum pump, pump oil, manual.

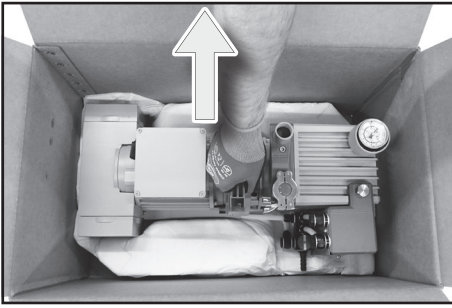

- ☞ Note that the **weight of the vacuum pump is approx. 55 lbs. (25 kg)**.
- ➔ Carefully lift the vacuum pump out of the packaging using the handle.

## *Initial operation / Pouring in the pump oil*

### **CAUTION**

- **The pump is supplied dry (i.e., without oil filling).** This is in order to ensure that oil cannot make its way from the rotary vane pump into the housing of the oil mist filter during transport. A can containing 0.5 liter (0.53 quarts) of rotary-pump oil is supplied with the pump. **Before starting the pump for the first time, pour in the oil** as described below.

### **Pouring in the oil:**

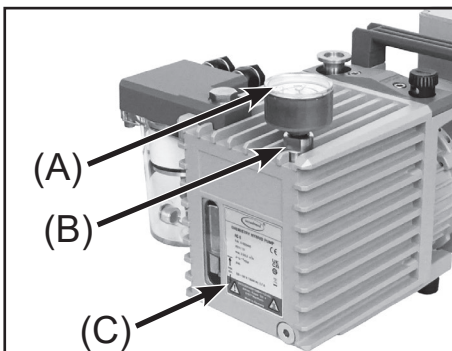

- ➔ Unscrew the manometer (A) with its adapter (B) from the housing of the rotary vane pump (open end wrench width 17 mm).
- ☞ Do not turn the manometer itself as leaks might be caused! Pay attention to the O-ring!

- ➔ Pour only approx. 350 ml (0.37 quarts) of oil into the pump (bringing oil level to "min." mark (C), approx.).
- ➔ Screw the manometer with its adapter carefully into the housing of the rotary vane pump (open end wrench width 17 mm).
- ☞ Pay attention to the O-ring!
- ☞ Do not turn the manometer itself as leaks might be caused!
- ➔ With inlet line closed, operate the pump for approx. 5-10 minutes.

- ☞ Note: Because new oil contains gas, a considerable degree of foaming can occur during operation with new oil, and oil could penetrate the oil separator.
- ➔ Remove the manometer with its adapter again.
- ➔ Add approx. 100 ml (0.11 quarts) of oil.
- ☞ As a rule, it is not necessary to use the maximum quantity of oil. **Do not overfill!**
- ➔ Screw the manometer with its adapter carefully into the housing of the rotary vane pump (open end wrench width 17 mm).
- ☞ Pay attention to the O-ring!
- ☞ Do not turn the manometer itself as leaks might be caused!

### ***Installing a pump in a vacuum system***

#### **! DANGER**

- ➔ If dangerous or polluting fluids, oil mist, or toxic or noxious gases could be released at the outlet, install an appropriate system to catch and dispose of those fluids or gases.

#### **! WARNING**

- ☞ Connect a gas-tight exhaust line at the pump outlet if necessary. Always vent exhaust gases appropriately (e.g., into a fume hood).
- ☞ Never block the gas outlet. The exhaust line must always be free of obstructions (no back pressure) to ensure an unimpeded discharge of gas. The cross-section of the outlet tubing must be at least the size of the pump's exhaust connection.
- ☞ Failure to connect the inlet and outlet lines correctly will cause overpressure! The outlet (hose nozzle) is marked "OUT".
- ☞ Particles and dust must not be aspirated. If necessary, you must install appropriate filters. You must ensure their suitability concerning gas flow, chemical resistance and resistance to clogging prior to use.

- ☞ Make sure ventilation is adequate, especially if the pump is installed in an enclosure, or if the ambient temperature is elevated. Provide external ventilation, if necessary.

## CAUTION

- Reduce the transmission of vibration. Prevent mechanical load due to rigid pipelines. Insert elastic hoses or flexible elements as couplings between the pump and rigid pipes.  
**Note:** Flexible elements will compress or flatten when evacuated if not designed for use under vacuum.
- Hose connections at the pump inlet must always be gas tight.
- Install a cold trap in front of the pump, if pumping aggressive or corrosive gases or vapors.
- A power failure may cause accidental ventilation of the pump or the vacuum system, if the manual gas ballast valve is open. If this constitutes a potential source of danger, take appropriate safety measures, e.g., install a solenoid operated gas ballast valve (see “Accessories”, pg. 45).
- The pump is supplied dry (i.e., without oil filling).  
**Before starting the pump for the first time, pour in the oil** as described in the above section “Initial operation / Pouring in the pump oil”, pg. 30.
- Check the power source and the pump’s rating plate to be sure that the power source and the equipment match in voltage, phase, and frequency.

## NOTICE

Keep a minimum distance of 2 in (5 cm) between the cooling fan and surrounding items (e.g., housing, walls, etc.), or else install an external automatic ventilation system. The mains plug is a disconnecting device to separate the pump from the supply voltage. Ensure that the mains plug is easily accessible at all times to allow the separation of the device from the power supply.



Use connecting hoses with large diameter and keep them as short as possible to avoid flow losses. Locate the pump as closely as possible to the application. Use only hoses at the inlet and outlet of the pump with an inner diameter at least as large as the diameter of the pump's connections.

Always install outlet tubing descending from the pump or provide other measures to avoid backflow of condensate towards the pump.

Use a suitable valve (see "Accessories", pg. 45) to isolate the pump from the vacuum application. This is to allow the pump to warm up before pumping condensable vapors and to clean the pump after use before it is switched off.

When assembling, ensure **vacuum-tightness**. After assembly, check the whole system for leaks.

Secure hose connections at the pump appropriately, e.g., with hose clamps, to protect against accidental detachment.

**Note:** The pump must only be operated in a horizontal position. When transporting a pump containing oil, take great care not to tilt the pump to an angle that would allow oil to make its way into the filter element.

### ***During operation***



➔ Vent and dispose of **potentially dangerous gases or vapors** at the outlet of the pump appropriately.



☞ Due to the high compression ratio, the pump may generate overpressure at the outlet. Check pressure compatibility with system components (e.g., exhaust tubing) at the outlet. Ensure that the pump outlet is neither blocked nor restricted.

☞ **Maximum ambient temperature:** 104 °F (40 °C)

Check the maximum temperatures, if installing the pump in a cabinet or a housing. Make sure ventilation is adequate, especially if the ambient temperature is elevated.

**CAUTION**

- If the pump is installed at an altitude of more than 6500 ft (2000 m) above mean sea level, check compatibility with applicable safety requirements, and adopt suitable measures. There is a risk of the motor overheating due to insufficient cooling.
- Check compatibility with the **maximally permitted pressures** at inlet and outlet and the **maximum pressure difference** between inlet and outlet ports.
- Check the **oil level** of the rotary vane pump every time before starting the pump, however at least once a week. Check the oil level more frequently if high amounts of gas or vapor are pumped.
- If pumping aggressive, corrosive or otherwise dangerous gases and vapors, take appropriate measures to protect personnel, pump, and environment. Use appropriate equipment such as cold trap, separator, oil separator, full flow oil filter, shut-off valve, or exhaust waste vapor condenser (see “Accessories”, pg. 45) as well as special oil.

**NOTICE**

The **ambient temperature** should be at least 54°F (12 °C). Otherwise the pump may not start because of the high oil viscosity at low temperature.

Pumping down can be started at any pressure at the inlet **below atmospheric pressure**.

Do not start the pump if the **pressure at the outlet port exceeds 16.0 psi (1.1 bar) absolute**.

**Continuous operation** is possible at any pressure below atmospheric pressure.

Oil consumption will increase at inlet pressures above 75 Torr (100 mbar). Check oil level more frequently.

Prevent internal condensation, transfer of liquids or dust. The pump unit as well as the diaphragms and valves will be damaged if liquids are pumped in significant amounts. Check the pump regularly for external soiling and deposits. Clean the pump if necessary to avoid an increase of the pump's operating temperature.

The motor is protected by a **self-hold thermal cutout in the winding**.

**Note:** Only a manual reset is possible. Switch off the pump and disconnect the electrical power cord. Identify and eliminate the cause of failure. Wait approximately five minutes before restarting the pump.

 **CAUTION**

- **Note:** In case of **supply voltage below 115 V**, the lock of the cutout might be impaired and the pump may restart on its own after sufficient cooling down. Take appropriate precautions, if an automatic restart of the pump may lead to a dangerous situation (e.g., switch off the pump and disconnect from the power source).

Avoid high heat supply (e.g., due to hot process gases). See "Technical data", pg. 22, for maximum permitted gas and ambient temperatures.

A warm up period (approximately 30 min.) is required to ensure that the rated ultimate vacuum and pumping speed as well as the full vapor pumping rate and chemical resistance of the pump are attained. To warm up the pump effectively before connecting to the vacuum application, install a shut-off valve (see "Accessories", pg. 45).

The attainable ultimate vacuum is limited by the properties of the vacuum vessel (leak-tightness, cleanliness and degassing of the inner surfaces), degassing of substances used and the condition of the pump oil (cleanliness, content of hydrocarbons with higher partial pressures).

Use the **manometer monitoring the pressure in the oil reservoir** of the HYBRID pump to check the operability of the diaphragm pump. If during the process the pressure inside the oil reservoir should rise significantly (manometer needle clearly in the red zone), it is necessary to take appropriate measures to reduce the inlet pressure.

**For the HYBRID principle to work it is necessary to prevent the pumped vapors from condensing inside the oil reservoir. Therefore the pressure inside the oil reservoir has to be lower than the vapor pressure of the pumped media at the oil's temperature (140°F (60°C)). If necessary, the volume of pumped vapors has to be reduced or a cold trap has to be installed.**

If no improvement is achieved even with the vacuum chamber being absolutely leak tight, this points to a potential failure of the diaphragm pump, e.g., a diaphragm crack. A more accurate check of the pressure inside the oil reservoir is possible with a more precise manometer, e.g., a DVR 2pro digital vacuum gauge. If a pressure higher than 19 Torr (25 mbar) is measured with inlet port and gas ballast valve closed, check the diaphragm pump and replace the diaphragms if necessary.

Any drop in the diaphragm pump's pumping speed produces a pressure increase in the oil reservoir. Although this does not have a direct effect on the pumping speed and on the ultimate vacuum attainable by the HYBRID pump, it does have a considerable effect on the aging of the oil and the HYBRID pump's chemical resistance.

All bearings are encapsulated and are filled with long-life lubricant. Under normal operating conditions, the drive system is maintenance free. The valves and diaphragms are wear parts. Aging of the oil of the rotary vane pump necessitates oil changes.

## ***Important notes regarding the use of gas ballast***

Gas ballast is a continuous purge to keep the pump's interior as clean as possible and to reduce the possibility of condensation inside the pump.

### **DANGER**

➔ Air and pumped media might react inside the pump or at the outlet of the pump and form hazardous or explosive mixtures, when you use air rather than inert gas for the gas ballast. This constitutes a risk of significant damage to equipment and/or facilities, a risk of personal injury or even loss of life.

### **WARNING**

☞ Make sure that air/gas intake through the gas ballast valve can never lead to hazardous, explosive or otherwise dangerous mixtures. If in doubt, use inert gas.

### **NOTICE**

To reduce condensation in the pump, do not pump vapor before the pump has reached its operating temperature. Open the gas ballast valve when pumping condensable vapors.

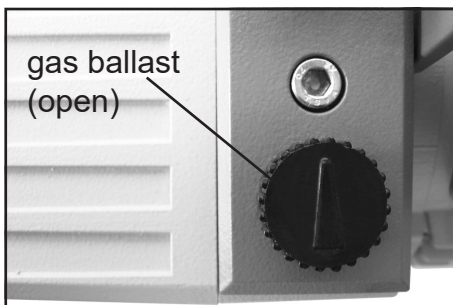

For **condensable vapors** (water vapor, solvents, etc.):

- Let the pump run **with gas ballast** to reduce condensation of pumped substances (water vapor, solvents, ....) in the pump or to decontaminate the pump oil from volatile substances.
- With gas ballast valve open, the ultimate vacuum will be reduced.
- Use inert gas for gas ballast to avoid the formation of explosive mixtures.
- To open and to close the gas ballast valve turn the gas ballast valve cap. The manual gas ballast valve is open if the arrow on the gas ballast cap is pointing towards the inlet of the pump respectively towards the labelling "Gasballast".

- Close the manual gas ballast valve by turning the cap 180°.

Operate the pump without gas ballast only in case of a clean system or when there are no condensable vapors.

## **NOTICE**

Do not pump vapors until the pump has reached its operating temperature. Install an in-line valve in the inlet line and open it only approx. 30 minutes after the pump has been started.

Check the maximum vapor inlet pressure. The pump can operate continuously at any pressure lower than the maximum specified inlet pressure for vapor. Avoid sudden vapor surges when evacuating commences (large inner surfaces, large-volume vacuum vessel).

Use a flow-control valve in the inlet line and open the valve gradually.

## ***Operating the pump with condensate in the catchpots***

## **NOTICE**

Observe the condensate levels in the catchpots of the separator at the inlet and of the oil mist filter. The condensate level in an optional separator at the inlet must always be kept below the bottom of the separator tube. The condensate level in the oil mist filter must always be kept below the bottom edge of the filter.

Drain condensate in time. To drain condensate, switch off and vent the pump. Then open drain screw of the catchpot. Condensate of the inlet catchpot (see "Accessories", pg. 45) in particular must not be drained while pump is operating.

In case of a clogged filter, oil mist might be visible in the oil filter housing, or the filter might be discolored or exhibit deposits on the inside. If the filter element is clogged, disassemble the oil mist filter and replace the filter element.

Under certain circumstances, clogged filter elements can be cleaned using suitable solvents. However, it is safer to use a new filter element (see section "Replacing the filter element in the oil mist filter", pg. 59).

Do not reuse separated oil if it is contaminated or discolored.

**! WARNING**

☞ **Important:** Comply with regulations when disposing of solvents/condensates. Recycle if possible; purify if contaminated.

### ***Pumping chemically aggressive or toxic gases and vapors***

**! DANGER**

➔ Avoid explosive conditions when compressing explosive and flammable substances/mixtures. In such instances, use inert gas for gas ballast.

**Attention:** The gas ballast of the diaphragm pump is permanently connected to the system.

**! WARNING**

☞ Implement special protective measures to protect personnel, pump, and environment.

**! CAUTION**

- Install a cold trap (see "Accessories", pg. 45), if the thermodynamic conditions of the application are such that vapors could condense in the rotary vane pump. Wait until the pump has reached its operating temperature before connecting it to the vacuum system.

**NOTICE**

Before switching off, allow the pump to run for a few minutes, initially with the rotary vane pump's gas ballast valve open and then with the gas ballast valve closed, after the pump has been isolated from the vacuum application. Prevent internal condensation, transfer of liquids or dust. The pump requires regular inspection and maintenance.

## **Shutdown**

### **NOTICE**

Has the pump been exposed to condensate?

- Before switching off, allow the pump to run for a few minutes, initially with the rotary vane pump's gas ballast valve open and then with the gas ballast valve closed, after the pump has been isolated from the vacuum application.

### **Long-term:**

- Separate the pump from the application.
- Drain condensates (catchpots of the separator at the inlet and of the oil mist filter).
- Flush the pump with dry inert gas.
- Carry out oil change (see "Oil change", pg. 41).
- Fill the pump completely with new oil (to above the "max." mark!).

Attention: Before restarting the pump, drain oil to the maximum oil level ("max." mark)!

- Close the manual gas ballast valve.
- Close inlet and outlet ports (e.g., with transport caps or blind flanges).
- Store the pump under dry conditions.
  
- Carry out oil change and maintenance prior to use if the pump has been stored for longer than one year.

**Note:** When transporting a pump containing oil, take great care not to tilt the pump to an angle that would allow oil to make its way into the filter element. Drain oil if necessary.



# Oil change

## DANGER

- ➔ Never operate the pump if parts of the pump are disassembled. Ensure that the pump cannot be operated accidentally.



- ➔ Before starting maintenance, isolate the pump from its application and disconnect the electrical power cord.
- ➔ **Note:** The pump or the pump oil might be contaminated with dangerous or corrosive process chemicals that have been pumped during operation. Adopt suitable decontamination measures if necessary. Take adequate precautions to protect people from the effects of dangerous substances if contamination has occurred. Ensure that the maintenance technician is familiar with the safety procedures which relate to the products processed by the pumping system.

## WARNING

- ➔ Use appropriate protective clothing, safety goggles and protective gloves. Avoid inhalation and skin contact.

## CAUTION

- Take adequate precautions when handling pump fluids, lubricants, and solvents. Use appropriate protective clothing, safety goggles and protective gloves to avoid excessive contact with the skin and possible skin irritations (including dermatitis).  
Comply with all relevant statutory requirements and regulations concerning the handling, storage and disposal of oil.



- Risk of scalding due to hot oil. Wear your personal protective equipment.

## NOTICE

Aging of the oil (as indicated by darker color compared to new oil, strange odor of the oil, particles in the oil, or contamination) necessitates an oil change. Depending on the application (especially if corrosive gases or vapors have been pumped) it may be appropriate to

check the oil frequently and to carry out an oil change, if necessary.

### **Under normal operating conditions:**

- Check oil level every time before starting the pump.
- Carry out an oil change once aging of the oil is indicated by darker color compared to new oil.
- Carry out oil changes at least once a year.
- Dispose of the used oil, which may be contaminated, according to all applicable regulations.

If the oil contains small quantities of water/solvent:

- ☞ The oil can be cleaned to a certain extent by operating the pump for 1 - 2 hours with the inlet line sealed and the gas ballast valve open.

### ***Oil change procedure***



- ☞ Carry out the oil change only after the pump has reached its normal operating temperature.
- ☞ Choose a suitable pad; oil may drip. Use a suitable container to catch the oil.
- ➔ Switch off the pump and isolate it from its application. Ventilate the pump to atmospheric pressure. Disconnect the electrical power cord.

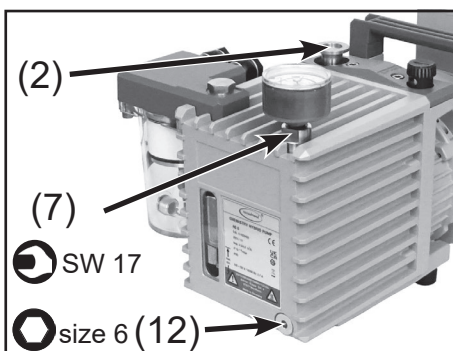

- ➔ To vent the oil reservoir, remove the manometer (7) with its adapter carefully (open end wrench width 17 mm). Pay attention to the O-ring! Do not turn the manometer itself as leaks might be caused!
- ➔ Place a suitable container below the oil outlet (12).
- ➔ Remove the oil drain plug (12) below the rating plate (Allen key size 6), paying attention to the O-ring.
- ➔ Tilt the pump slightly and catch the oil in a suitable container.

- ☞ Dispose of the used oil according to regulations.
- ➔ Screw in oil drain plug (12) with O-ring.
- ➔ Screw in manometer (7) with O-ring.

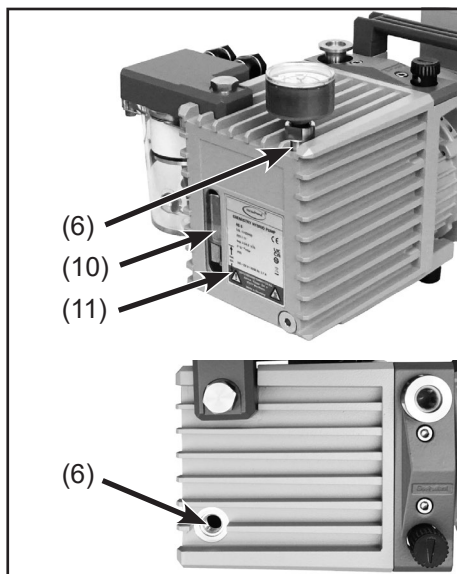

- ➔ To flush the pump, pour in fresh oil (approx. 0.05 quarts (50 ml)) through the pump inlet (2) (remove separator if necessary).
- ➔ Operate the pump briefly. Drain flushing oil and repeat flushing procedure, if necessary, until all contaminations are flushed out.
- ➔ Remove the manometer (see above). Add fresh oil (at first approx. 0.37 quarts (350 ml) only) through the oil inlet port (6) for the oil level to reach the "min." mark (11). Observe the oil level through the sight glass (10).

- ➔ Close the oil inlet port (8). Operate the pump with **closed inlet** for approx. 5-10 minutes.
- ➔ Top off the oil (add approx. 0.11 quarts (100 ml)). As a rule, it is not necessary to use the maximum quantity of oil. **Do not overfill!**
- ➔ Screw in manometer with O-ring.

**Note:** The oil degasses and foams at low pressures. This is a welcome condition which helps to protect the pump against corrosion and to prolong the working life of the oil.

The quantity, condition and quality of the pump oil have a decisive effect on the pump's performance and dependability.

**Important:** It may not be possible to reach the specified ultimate vacuum if an oil other than **VACUUBRAND B-oil** is used. Similarly, failure to use the recommended oil may impair cold-start performance and pump lubrication!

## ***Notes on the pump oil***

The **standard oil** for VACUUBRAND rotary vane pumps is the **B-oil**. This is a mineral oil, which is used for the first filling of the pump.

The advantages of the B-oil are: Flat viscosity curve, low vapor pressure, good chemical resistance, extended stability when pumping oxidants, acid or basic vapors compared to conventional mineral oils.

Certain pumped media may attack the oil in the pump. It is at the users' responsibility to check if the materials of the wetted parts are resistant against the pumped substances. This is also mandatory for the pump oil.

### **VACUUBRAND B-oil**

1 liter (1.06 qt) .....	<b>20687010</b>
5 liter (5.3 qt) .....	<b>20687011</b>
20 liter (5.3 gal).....	<b>20687012</b>
200 liter (52.8 gal).....	<b>20687013</b>

# Accessories



Separator AK R at the inlet.....**20698006**

Protection of the pump against damaging liquid and solid substances, protection of the vacuum chamber against back flow of pump oil.



Shut-off valve  
Ball valve VKE 16, KF DN 16.....**20675504**



Butterfly valve VS 16C .....**20665007**

Hose nipple, aluminum, for hoses DN 19.....**20662531**

Vacuum hose (rubber, DN 20).....**20686005**

PTFE vacuum hose (antistatic) with stainless steel small flanges. The inner side of the PTFE hose is smooth for increased chemical resistance, reduced deposits and high conductance

KF DN 16, 500 mm (19.7").....**20686030**

KF DN 16, 1000 mm (39.4").....**20686031**

KF DN 25, 500 mm (19.7").....**20686032**

KF DN 25, 1000 mm (39.4").....**20686033**

Vacuum gauge DCP 3000 with gauge head VSP 3000 (Pirani) .....**20683190**

7.5\*10<sup>2</sup> Torr - 1\*10<sup>-3</sup> Torr (1\*10<sup>3</sup> mbar - 1\*10<sup>-3</sup> mbar)

100-230V 50/60 Hz

Vacuum gauge VACUU·VIEW extended .....**20683210**

8.25\*10<sup>2</sup> Torr - 1\*10<sup>-3</sup> Torr (1100 mbar - 0.001 mbar)

100-230V 50/60 Hz

Maintenance kit RC 6 .....**20649990**  
(rotary vane pump and diaphragm pump)

- ➡ A service manual with exploded view drawings, spare parts list and directions for repair is available on request.
- 👉 The service manual is intended for trained service people only.

# Troubleshooting

Fault	Possible cause	Remedy
<input type="checkbox"/> Pump does not start.	<ul style="list-style-type: none"> <li>➔ Electrical power cord not plugged in, electrical supply failure?</li> <li>➔ Supply voltage does not correspond with the pump (see rating plate)?</li> <li>➔ Oil temperature below 54°F (12°C)?</li> <li>➔ Oscillating starting behavior of the pump?</li> <li>➔ Pump unit of rotary vane pump contaminated?</li> <li>➔ Motor thermally overloaded?</li> <li>➔ Overpressure in outlet line?</li> <li>➔ Oil mist filter clogged (filter element in contact with oil) or over-filled?</li> <li>➔ Pump seized?</li> </ul>	<ul style="list-style-type: none"> <li>✓ Plug in power cord. Check fuse.</li> <li>✓ Connect pump to a suitable supply voltage.</li> <li>✓ Operate the pump in suitable ambient conditions.</li> <li>✓ Normal behavior, no fault in case of a cold pump.</li> <li>✓ Perform maintenance or clean the pump unit.</li> <li>✓ Allow motor to cool down (&lt; 50°C (122°F)), identify and eliminate cause of failure. Manual reset is necessary. Switch off pump or unplug. Provide sufficient ventilation.</li> <li>✓ Remove blockage in line, open valve.</li> <li>✓ Drain oil, replace filter element if necessary.</li> <li>✓ See below.</li> </ul>
<input type="checkbox"/> Pump does not achieve its ultimate vacuum or usual pumping speed.	<ul style="list-style-type: none"> <li>➔ Measuring procedure or vacuum gauge not suitable for the application?</li> <li>➔ Inlet blocked?</li> <li>➔ Centring ring at small flange connection not correctly positioned?</li> <li>➔ Long, narrow vacuum line?</li> </ul>	<ul style="list-style-type: none"> <li>✓ Choose a suitable measuring procedure or vacuum gauge.</li> <li>✓ Open inlet. Ensure that the inlet line does not become blocked.</li> <li>✓ Check small flange connections.</li> <li>✓ Use lines with larger diameter, length as short as possible.</li> </ul>

Fault	Possible cause	Remedy
<input type="checkbox"/> Pump does not achieve its ultimate vacuum or usual pumping speed.	<ul style="list-style-type: none"> <li>➔ Leak in the pipeline or vacuum system?</li> <li>➔ Long, narrow vacuum line?</li> <li>➔ Not enough oil?</li> <li>➔ Wrong type of oil?</li> <li>➔ Oil contaminated (also with solvents)?</li> <li>➔ Outgassing substances or vapor generated in the process?</li> <li>➔ Pump has not yet reached its operating temperature?</li> <li>➔ None of the above mentioned causes?</li> </ul>	<ul style="list-style-type: none"> <li>✓ Check pump directly - connect vacuum gauge directly at pump inlet - then check connection, pipeline and vacuum system if necessary.</li> <li>✓ Use lines with larger diameter, length as short as possible.</li> <li>✓ Top up oil to correct level.</li> <li>✓ Change oil and flush with oil (see "Oil change").</li> <li>✓ Change oil and flush with oil (see "Oil change").</li> <li>✓ Check process parameters.</li> <li>✓ Allow the pump to reach its operating temperature.</li> <li>✓ Contact local distributor.</li> </ul>
<input type="checkbox"/> Pump too noisy or strange noise.	<ul style="list-style-type: none"> <li>➔ Too much oil?</li> <li>➔ Motor thermally overloaded?</li> <li>➔ Diaphragm damaged?</li> <li>➔ Pump seized?</li> <li>➔ Overpressure in outlet line?</li> <li>➔ None of the above mentioned causes?</li> </ul>	<ul style="list-style-type: none"> <li>✓ Lower oil level to mark "max.".</li> <li>✓ Allow motor to cool down (&lt; 50°C (122°F)), identify and eliminate cause of failure. Provide sufficient ventilation.</li> <li>✓ Replace diaphragm.</li> <li>✓ See below.</li> <li>✓ Remove blockage in line, open valve.</li> <li>✓ Contact local distributor.</li> </ul>
<input type="checkbox"/> Oil in the inlet line.	<ul style="list-style-type: none"> <li>➔ Back diffusion (small amount of oil, oil film)?</li> <li>➔ Back streaming (large amount of oil)?</li> </ul>	<ul style="list-style-type: none"> <li>✓ Install a sorption trap or a separator, if necessary.</li> <li>✓ Contact local distributor.</li> </ul>



Fault	Possible cause	Remedy
<input type="checkbox"/> Oil leakage.	<ul style="list-style-type: none"> <li>➔ Oil spilled?</li> <li>➔ Other cause?</li> </ul>	<ul style="list-style-type: none"> <li>✓ Absorb the oil and dispose of according to regulations.</li> <li>✓ Contact local distributor.</li> </ul>
<input type="checkbox"/> High oil consumption.	<ul style="list-style-type: none"> <li>➔ High inlet pressure?</li> <li>➔ Operation with gas ballast?</li> <li>➔ Oil level too high?</li> </ul>	<ul style="list-style-type: none"> <li>✓ Normal. Top off oil whenever necessary. Install oil mist filter at outlet.</li> <li>✓ Top off oil whenever necessary. Install oil mist filter at outlet.</li> <li>✓ Lower oil level to mark "max.".</li> </ul>
<input type="checkbox"/> Fast aging of the oil.	<ul style="list-style-type: none"> <li>➔ Pumping aggressive gases?</li> <li>➔ Condensation in the pump?</li> <li>➔ Oil mist filter defective?</li> <li>➔ Diaphragm pump does not reach its pumping speed?</li> </ul>	<ul style="list-style-type: none"> <li>✓ Use suitable oil.</li> <li>✓ Use separator or cold trap.</li> <li>✓ Replace filter. Check safety pop valve.</li> <li>✓ Perform maintenance of diaphragm pump.</li> </ul>
<input type="checkbox"/> Pump seized.	<ul style="list-style-type: none"> <li>➔ Ambient temperature too high (&gt; 104 °F (40°C))?</li> <li>➔ None of the above mentioned causes?</li> </ul>	<ul style="list-style-type: none"> <li>✓ Provide sufficient ventilation.</li> <li>✓ Contact local distributor.</li> </ul>

# Replacing diaphragms and valves

☞ Please read section "Replacing diaphragms and valves" completely before starting maintenance.

The pictures may show other versions of pumps. This does not change the method of replacing diaphragms and valves.

## DANGER

➔ Never operate the pump if covers or other parts of the pump are disassembled.



➔ Before starting maintenance, **disconnect the electrical power cord. Wait five seconds** after isolating the equipment from AC power to allow the capacitors to discharge.

➔ Ensure that the pump cannot be operated accidentally.

➔ **Note:** The pump might be contaminated with the process chemicals that have been pumped during operation. Ensure that the pump is decontaminated before maintenance.

➔ Avoid the release of pollutants.

## WARNING

☞ **Never operate a defective or damaged pump.**

☞ Take adequate precautions to protect people from the effects (e.g., in case of inhalation or skin contact) of dangerous substances that may have contaminated the pump and may be released upon disassembly. Ensure that the maintenance technician is familiar with the safety procedures which relate to the products processed by the pumping system.

Use appropriate protective clothing, safety goggles and protective gloves.

☞ Check every motor capacitor regularly by measuring its capacity and estimating its service life. Replace old capacitors early enough to prevent a failure. The capacitors must be replaced by a trained electrician.

☞ Allow sufficient cooling of the pump before starting maintenance. Drain condensate, if applicable.

☞ **Vent the pump and isolate it from the vacuum system before you start maintenance.**

**NOTICE**

**Ensure that maintenance is done only by suitably trained and supervised technicians.**

The valves and diaphragms as well as the motor capacitors are wear parts. At the latest if the pressure inside the oil reservoir should rise significantly (manometer needle clearly in the red zone), or in case of increased noise level, the pump interior, the diaphragms and the valves must be cleaned and the diaphragms and valves must be checked for cracks or other damage.

All bearings are encapsulated and are filled with long-life lubricant. Under normal operating conditions, the drive system is maintenance free.

The operability of the diaphragm pump can be checked as well by measuring the pressure in the oil reservoir:

- ➔ Unscrew the manometer with its adapter (open end wrench width 17 mm). Remove the hose nozzle from the distributor plate (outlet) and install at the oil inlet. Make sure the O-ring is seated correctly.
- ➔ Using a suitable vacuum gauge (e.g., DVR 2pro) and making sure that it is correctly calibrated, measure the pressure in the oil reservoir. When the pump operates with the inlet line closed, the measured pressure in the oil reservoir should be less than 25 mbar (19 Torr) (with gas ballast valve of rotary vane pump closed).
- ➔ Remove the hose nozzle from oil inlet. Reinstall it in the distributor plate and reassemble the manometer with O-ring.

In demanding circumstances, it may be efficient to check and clean the pump heads on a regular basis. In normal use, the lifetime of the diaphragms and valves is typically 15,000 operating hours.

- Prevent internal condensation, transfer of liquids or dust. The diaphragms and valves will be damaged if liquid is pumped in significant amount.
- Carry out maintenance frequently if the pump is exposed to corrosive media or in case of deposits.
- Regular maintenance will improve the lifetime of the pump and also protect both users and the environment.

Diaphragm.....	<b>20639786</b>
Valve.....	<b>20638440</b>
Vacuum gauge DVR 2pro .....	<b>20682906</b>
Diaphragm key (width 66 mm) .....	<b>20636554</b>

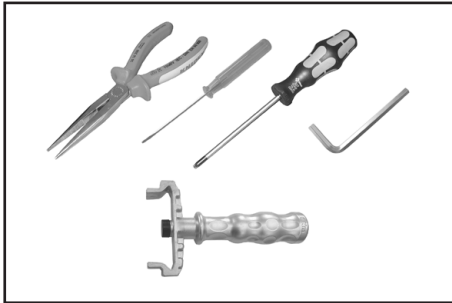

**Tools required (metric):**

- Phillips screw driver size 2
- Open-ended wrench 14/17 mm
- 5 mm wide Allen key
- Diaphragm key width 66 mm

***Cleaning and inspecting the diaphragm pump heads***

- ➔ **Drain the catch pot** of the oil mist filter before beginning maintenance to prevent leaking of condensate!
- ➔ **Drain oil** (see " Oil change") to prevent oil from making its way into the filter element. Refill pump with oil before restarting the pump!
- ➔ For maintenance, lay the pump on its side with the pump head to be maintained at the top. Support the pump appropriately.  
Attention: Prevent any damage to the oil mist filter or to the manometer. Do not use the oil mist filter to prop up the pump.



- ➔ Loosen the union nuts of the hose connections at the pump head with an open-ended wrench (17 mm).

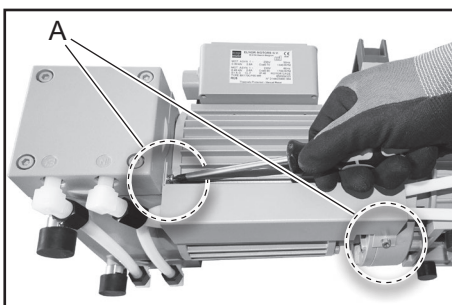

- ➔ Remove the cover plate. Use a Phillips screw driver size 2 to loosen both screws (A). Pay attention to lock washers.

## View of the disassembled pump head parts

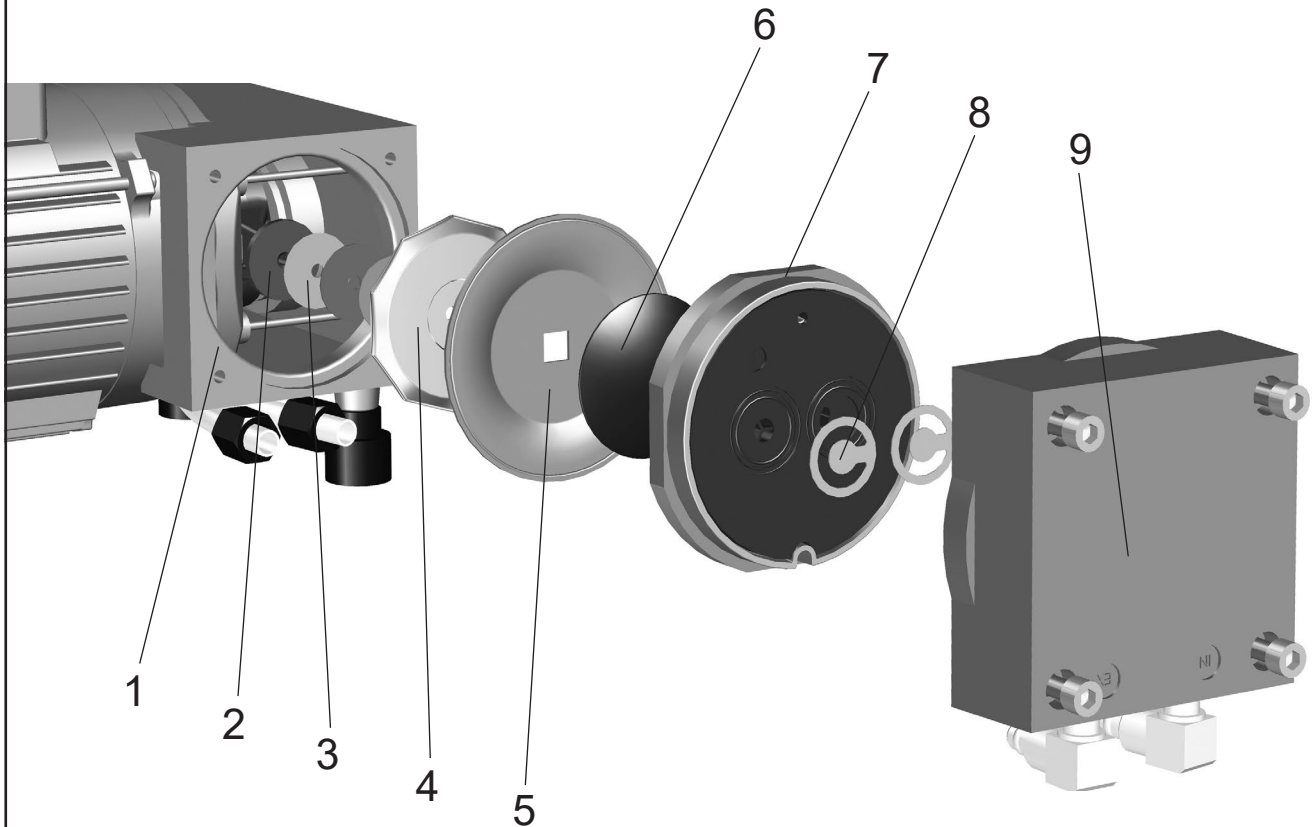

- 1: Housing
- 2: Connecting rod
- 3: Washer
- 4: Diaphragm support disc
- 5: Diaphragm
- 6: Diaphragm clamping disc  
with square head screw

- 7: Head cover
- 8: Valve
- 9: Housing cover with  
housing cover insert



- ➔ Turn the fittings with an open-ended wrench (14 mm) to detach the hoses from the pump heads (1/4 of a turn at maximum).
- ☞ Do not remove the elbow fittings from the pump heads; during reassembly a leak may result.

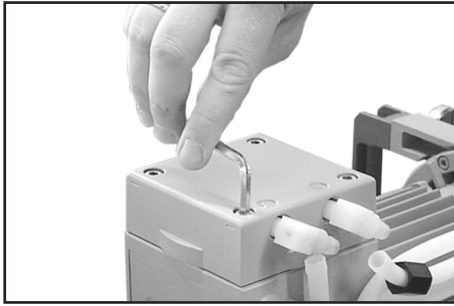

- ➔ Disassemble the housing cover to check the diaphragm and the valves.
- ➔ Unscrew four Allen screws with a 5 mm wide Allen key. Remove the housing cover with housing cover insert together with the head cover and the valves (head cover with valves will remain within the housing cover).

- ☞ Never remove parts by using a pointed or sharp-edged tool (e.g., screw driver). We recommend to use a rubber mallet or compressed air (to be blown carefully into port).
- ➔ Remove the head cover carefully from the housing cover. Note the position and orientation of the valves and remove them.
- ☞ Replace valves if necessary.
- ☞ Check diaphragm for damage and replace if necessary.
- ☞ Use petroleum ether or industrial solvent to remove deposits. Do not inhale vapors.

## Replacing the diaphragm

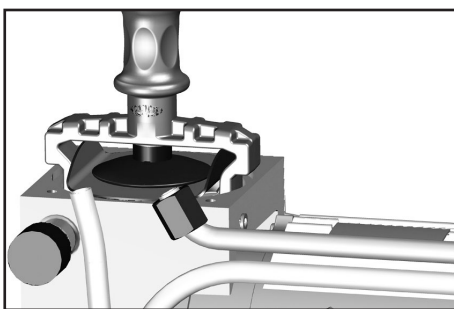

- ➔ Lift diaphragm carefully sidewise.
- ☞ Never use a pointed or sharp-edged tool to lift the diaphragm.
- ➔ Use the diaphragm key to grip the diaphragm support disc below the diaphragm.
- ➔ Unscrew diaphragm support disc with diaphragm and diaphragm clamping disc.
- ☞ If the old diaphragm is difficult to separate from the diaphragm support disc, immerse assembly in naphtha or petroleum ether. Do not inhale vapors!
- ➔ Check for washers between the diaphragm support disc and the connecting rod. Do not mix the washers from the different pump heads, since these are set at the factory to ensure proper pump performance. Make sure that the original number is reassembled at the individual pump head.

- ☞ Too few washers: The pump will not attain vacuum specification. Too many washers: Diaphragm clamping disc will hit head cover, causing noisy operation and possibly causing the pump to seize up.

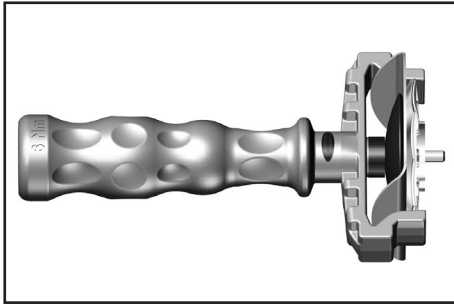

- ➔ Position new diaphragm between diaphragm clamping disc with square head screw and diaphragm support disc.
- ☞ Note: Position diaphragm with pale side towards diaphragm clamping disc (facing pump chamber).

- ☞ Make sure that the square head screw of the diaphragm clamping disc is correctly seated in the guide hole of the diaphragm support disc.
- ➔ Lift the diaphragm at the side. Place the diaphragm carefully together with diaphragm clamping disc and diaphragm support disc in the diaphragm key.
- ☞ Avoid damage of the diaphragm: Do not excessively bend or crease the diaphragm.

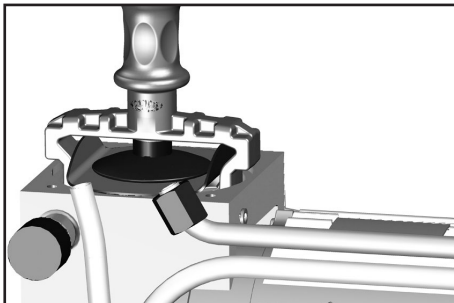

- ☞ Assemble the original number of washers between diaphragm support disc and connecting rod.
- ➔ Screw diaphragm clamping disc , diaphragm, diaphragm support disc, and washers to connecting rod.

- ➔ Optimum torque for the diaphragm support disc: 4.4 ft·lb<sub>f</sub> (6 Nm), it is recommended to use a torque wrench. Attach torque wrench to diaphragm key (hexagonal bolt 6 mm wide).  
Note: Never use the diaphragm key with any additional tools like tongs or Allen keys without appropriate torque limitation.

## Assembling the pump heads

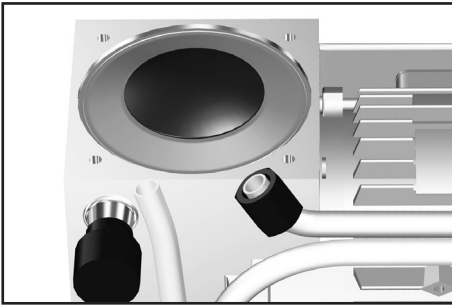

- ➔ Bring the diaphragm into a position, in which it is in contact with the housing and centered with respect to the bore.

- ➔ Place the head cover over the diaphragm. Check for its correct orientation by aligning it beforehand with the housing cover which has to be put over it later on.
- ☞ Pay attention that the diaphragm stays positioned centrally so that it will become clamped uniformly between housing and head cover.

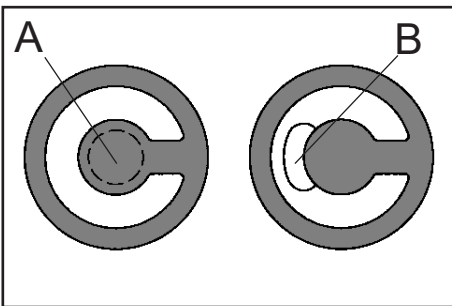

- ➔ Place the valves at their respective positions on the head cover.
- ☞ Make sure that the valves are correctly seated. See figure for the correct position of the valves: Valves at the outlet with round centered opening (A) under valve; valves at the inlet with kidney-shaped opening (B) beside valve.

- ➔ Place the housing cover with housing cover insert onto the head cover.
- ➔ By turning the eccentric bushing, bring the connecting rod into the upper turning point position (max. stroke of the rod).



- ➔ Loosely screw in the Allen head screws at the head cover diagonally at first slightly with a 5 mm wide Allen key, then tighten.
- ☞ Recommended torque: 8.9 ft·lb<sub>f</sub> (12 Nm).



## Assembling the connecting hose

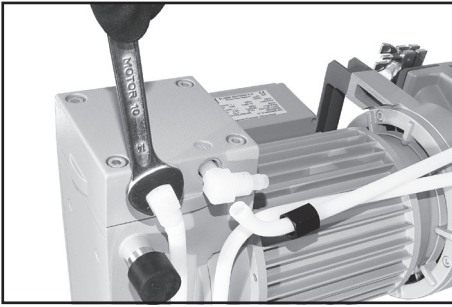

- ➔ Slip the hoses onto the hose connectors by turning the fittings with an open-ended 14 mm wrench.

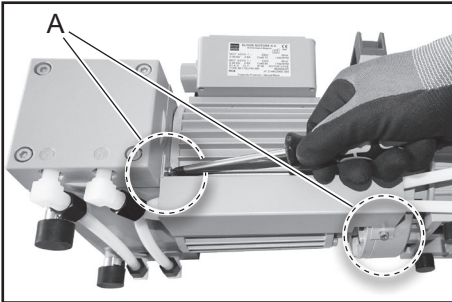

- ➔ Assemble the cover plate. Pay attention to lock washers.

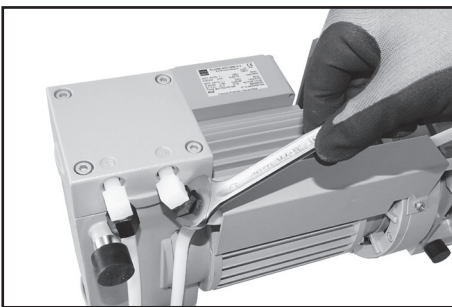

- ➔ Tighten the union nuts of the hose connections at the pump heads with an open-ended 17 mm wrench.
- 👉 Tighten union nuts first by hand and then tighten one full turn using the open ended wrench.

**Replace diaphragm and valves of the opposite side of the pump in the same way.**

- ➔ Put the pump in normal operating position.

👉 **Attention:** Make sure that the pump is filled with oil before switching it on, refill oil if necessary (see "Oil change", pg. 41)!

## ***Checking the operability of the diaphragm pump***

Check the operability of the diaphragm pump by measuring the pressure in the oil reservoir:

- ➔ Unscrew the manometer with its adapter (open end wrench width 17 mm). Remove the hose nozzle from the distributor plate (outlet) and install at the oil inlet. Make sure the O-ring is seated correctly.
- ➔ Using a suitable vacuum gauge (e.g., DVR 2pro) and making sure that it is correctly calibrated, measure the pressure in the oil reservoir. When the pump operates with the inlet line closed, the measured pressure in the oil reservoir should be less than 25 mbar (19 Torr) (with gas ballast valve of rotary vane pump closed).
- ➔ Remove the hose nozzle from oil inlet. Reinstall it in the distributor plate and reassemble the manometer with O-ring.

### **If the pump does not achieve the ultimate vacuum:**

- Whenever the diaphragms and valves have been replaced, a break-in period of several hours is required before the pump achieves its ultimate vacuum.
- In case of an unusual noise, switch off pump immediately and check clamping disc positions.

If the specified ultimate vacuum is not achieved, and if this does not change after the break-in period:

Check hose connectors at pump heads for leaks. If necessary recheck valve seats and pump chambers.

## Replacing the filter element in the oil mist filter

Filter element FO DN 10 .....**20640187**

- ➔ Use a 5 mm wide Allen key to remove the drain plug (note O-ring fitted on drain plug). Drain condensate from catchpot.
- ➔ Position the pump on the side so that it rests on the side with the power switch. Remove the Allen screws (5 mm wide Allen key) and remove the catchpot (note sealing ring).
- ➔ Using a 5 mm wide Allen key, remove the Allen screw in the center of the bottom filter thrust plate. Remove the filter element, both filter thrust plates, and the top O-ring.
- ☞ Clean or replace the filter element. Dispose of oil and filter element in accordance with regulations.
- ➔ Assemble again in reverse order. Make sure that the O-ring and the sealing ring are correctly seated.

## Inspecting the safety pop valve

Safety pop valve .....**20638836**

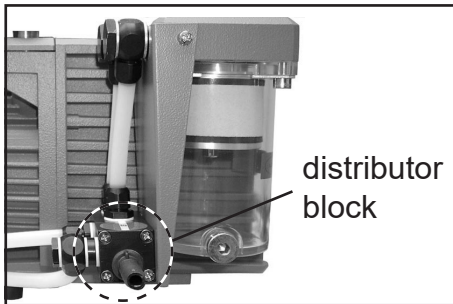

- ➔ Remove four countersunk screws and lift off the distributor block.
- ☞ Note the valve's position before removing it. Replace the valve if it is damaged.
- ➔ Assemble again in reverse order.

## Repair - Maintenance - Return - Calibration

### **IMPORTANT**

Every employer (user) is held responsible for the health and safety of his employees. This also applies to service personnel performing repair, maintenance, return or calibration.

The **health and safety clearance form** informs the contractor about any possible contamination of the device and forms the basis for the risk assessment.

**In case of devices which have been in contact with biological substances of risk level 2 contact the VACUUBRAND service absolutely before dispatching the device. These devices have to be completely disassembled and decontaminated by the user prior to shipment. Do not return devices which have been in contact biological substances of risk level 3 or 4. These devices cannot be checked, maintained or repaired. Also decontaminated devices must not returned to VACUUBRAND due to a residual risk.**

The same conditions apply to on-site work.

**No repair, maintenance, return or calibration is possible unless the correctly completed health and safety clearance form is returned. Devices sent are rejected if applicable.** Send a completed copy of the **health and safety clearance form** to us in advance. The declaration must arrive before the equipment. Enclose a second completed copy with the product.

Remove all components from the device that are no original VACUUBRAND components. VACUUBRAND will not be responsible for lost or damaged components that are no original components.

**Drain the device completely of fluids and residues. Decontaminate the device.** Close all openings airtight especially if using substances hazardous to health.

To expedite repair and to reduce costs, please enclose a detailed description of the problem and the product's operating conditions with every product returned.

If you do not wish a repair on the basis of our **quotation**, the device may be returned to you disassembled and at your expense.

In many cases, the components must be cleaned in the factory prior to repair.

For cleaning we use an environmentally friendly water based process. Unfortunately the combined attack of elevated temperature, cleaning agent, ultrasonic treatment and mechanical stress (from pressurised water) may result in damage to the paint. Please mark in the health and safety clearance form if you wish a repaint at your expense just in case such a damage should occur. We will also replace parts for cosmetic reasons at your request and at your expense.

### **Before returning the device**

Pack the device properly, if necessary, please order original packaging materials at your costs.

Mark the package completely

Enclose the completed [health and safety clearance form](#).

Notify the carrier of any possible contamination if required.

### **Scrapping and waste disposal**

Dispose of the equipment and any components removed from it safely in accordance with all local and national safety and environmental requirements. Particular care must be taken with components and waste oil which have been contaminated with dangerous substances from your processes. Do not incinerate fluoroelastomer seals and O-rings. You may authorize us to dispose of the equipment **at your expense**. Otherwise we return the device at your expense.



# Warranty

VACUUBRAND shall be liable for insuring that this product, including any agreed installation, has been free of defects at the time of the transfer of risk.

VACUUBRAND shall not be liable for the consequences of improper handling, use, servicing or operation of this product or the consequences of normal wear and tear of wearing parts such as diaphragms, seals, valves, vanes, condensers, oil and the breakage of glass or ceramic parts, for the consequences of chemical, electrochemical or electrical influences or the failure to follow the instructions in this manual.

Claims for defects against VACUUBRAND shall be limited to one year from delivery. The same shall apply to claims for damages irrespective of legal grounds.

For further information on general terms and conditions refer to [www.vacuubrand.com](http://www.vacuubrand.com).

**EG-Konformitätserklärung für Maschinen**  
**EC Declaration of Conformity of the Machinery**  
**Déclaration CE de conformité des machines**



Hersteller / Manufacturer / Fabricant:

**VACUUBRAND GMBH + CO KG** · Alfred-Zippe-Str. 4 · 97877 Wertheim · Germany

Hiermit erklärt der Hersteller, dass das Gerät konform ist mit den Bestimmungen der Richtlinien:

Hereby the manufacturer declares that the device is in conformity with the directives:

Par la présente, le fabricant déclare, que le dispositif est conforme aux directives:

- 2006/42/EU
- 2011/65/EU, 2015/863

Drehschieberpumpe / Rotary vane pump / Pompe à palettes:

Typ / Type / Type: **RC 6**

Artikelnummer / Order number / Numéro d'article: 20798560, 20798561, 20798562, 20798566, 22614824

Seriennummer / Serial number / Numéro de série: Siehe Typenschild / See rating plate / Voir plaque signalétique

Angewandte harmonisierte Normen / Harmonized standards applied / Normes harmonisées utilisées:

DIN EN ISO 12100:2011, DIN EN 61010-1:2020, IEC 61010-1:2010 (Ed. 3), DIN EN 1012-2:2011

DIN EN IEC 63000:2019

Bevollmächtigter für die Zusammenstellung der technischen Unterlagen / Person authorised to compile the technical file / Personne autorisée à constituer le dossier technique:

Dr. Constantin Schöler · VACUUBRAND GMBH + CO KG · Germany

Ort, Datum / place, date / lieu, date: Wertheim, 10.05.2022

(Dr. Constantin Schöler)

*Geschäftsführer / Managing Director /  
Gérant*

ppa.

  
(Jens Kaibel)

*Technischer Leiter / Technical Director /  
Directeur technique*

---

**VACUUBRAND GMBH + CO KG**

Alfred-Zippe-Str. 4  
97877 Wertheim

Tel.: +49 9342 808-0

Fax: +49 9342 808-5555

E-Mail: [info@vacuubrand.com](mailto:info@vacuubrand.com)

Web: [www.vacuubrand.com](http://www.vacuubrand.com)



## Declaration of Conformity



Manufacturer:

**VACUUBRAND GMBH + CO KG** · Alfred-Zippe-Str. 4 · 97877 Wertheim · Germany

Hereby the manufacturer declares that the device is in conformity with the directives:

- Supply of Machinery (Safety) Regulations 2008 (S.I. 2008 No. 1597, as amended by S.I. 2019 No. 696)
- The Restriction of the Use of Certain Hazardous Substances in Electrical and Electronic Equipment Regulations 2012 (S.I. 2012 No. 3032)

Rotary vane pump:

Type: **RC 6**

Order number: 20798560, 20798561, 20798562, 20798566, 22614824

Serial number: See rating plate

Harmonized standards applied:

EN ISO 12100:2010, EN 61010-1:2010+A1:2019, EN 1012-2:1996+A1:2009

EN IEC 63000:2018

Person authorised to compile the technical file:

Dr. Constantin Schöler · VACUUBRAND GMBH + CO KG · Germany

Place, date: Wertheim, 10.05.2022

(Dr. Constantin Schöler)

*Managing Director*

ppa.

  
(Jens Kaibel)

*Technical Director*

---

**VACUUBRAND GMBH + CO KG**

Alfred-Zippe-Str. 4  
97877 Wertheim

Tel.: +49 9342 808-0

Fax: +49 9342 808-5555

E-Mail: [info@vacuubrand.com](mailto:info@vacuubrand.com)

Web: [www.vacuubrand.com](http://www.vacuubrand.com)





**DECLARATION OF CONFORMITY – China RoHS 2**

VACUUBRAND GMBH + CO KG has made reasonable efforts to ensure that hazardous materials and substances may not be used in its products.

In order to determine the concentration of hazardous substances in all homogeneous materials of the subassemblies, a “Product Conformity Assessment” (PCA) procedure was performed. As defined in GB/T 26572 the “Maximum Concentration Value” limits (MCV) apply to these restricted substances:

- Lead (Pb): 0.1%
- Mercury (Hg): 0.1%
- Cadmium (Cd): 0.01%
- Hexavalent chromium (Cr(+VI)): 0.1%
- Polybrominated biphenyls (PBB): 0.1%
- Polybrominated diphenyl ether (PBDE): 0.1%

**Environmentally Friendly Use Period (EFUP)**

EFUP defines the period in years during which the hazardous substances contained in electrical and electronic products will not leak or mutate under normal operating conditions. During normal use by the user such electrical and electronic products will not result in serious environmental pollution, cause serious bodily injury or damage to the user’s assets. The Environmentally Friendly Use Period for VACUUBRAND products is 40 years.



MATERIAL CONTENT DECLARATION FOR VACUUBRAND PRODUCTS						
有毒有害物质或元素 Hazardous substances						
部件名称 Part name	铅 Pb	汞 Hg	镉 Cd	六价铬 Cr(+VI)	多溴联苯 PBB	多溴二苯醚 PBDE
包装 Packaging	0	0	0	0	0	0
塑料外壳 / 组件 Plastic housing / parts	0	0	0	0	0	0
真空油 Vacuum oil	0	0	0	0	0	0
电池 Battery	0	0	0	0	0	0
玻璃 Glass	X	0	0	0	0	0
电子电气组件 Electrical and electronic parts	X	0	0	0	0	0
控制器 / 测量设备 Controller / measuring device	X	0	0	0	0	0
金属外壳 / 组件 Metal housing / parts	X	0	0	0	0	0
电机 Motor	X	0	0	0	0	0
配件 Accessories	X	0	0	0	0	0

此表格是按照SJ/T 11364-2014中规定所制定的。  
This table is created according to SJ/T 11364-2014.

- O: 表示该有毒有害物质在该部件所有均质材料中的含量均在GB/T 26572规定的限量要求以下。  
O: Indicates that the above mentioned hazardous substance contained in all homogeneous materials of the part is below the required limit as defined in GB/T 26572.
- X: 表示该有毒有害物质至少在该部件某一均质材料中的含量超出GB/T 26572规定的限量要求。  
X: Indicates that the above mentioned hazardous substance contained in at least one of the homogeneous materials of this part is above the required limit as defined in GB/T 26572.

电池、玻璃器皿和配件可能不属于所附设备所包含的内容，它们可能有各自单独的EFUP标记和/或可能正在维护其部件EFUP标记的更新。

Batteries, glassware and accessories might not be content of the enclosed device and may have its own EFUP-marking and/or might be maintaining parts with changing EFUP-marking.

除上表所示信息外，还需声明的是，这些部件并非是有意图用铅（Pb）、汞（Hg）、镉（Cd）、六价铬（Cr(+VI)）、多溴联苯（PBB）或多溴二苯醚（PBDE）来制造的。

Apart from the disclosures in the above table, the subassemblies are not intentionally manufactured or formulated with lead (Pb), mercury (Hg), cadmium (Cd), hexavalent chromium (Cr+VI), polybrominated biphenyls (PBB), and polybrominated diphenyl ethers (PBDE).

Products manufactured by VACUUBRAND may enter into further devices (e.g., rotary evaporator) or can be used together with other appliances (e.g., usage as booster pumps).

With these products and appliances in particular, please note the EFUP labeled on these products.

VACUUBRAND will not take responsibility for the EFUP of those products and appliances.

Place, date: Wertheim, 06 September 2022



(Dr. Constantin Schöler)  
Managing Director

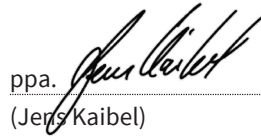

ppa. (Jens Kaibel)  
Technical Director

**VACUUBRAND GMBH + CO KG**

Alfred-Zippe-Str. 4  
97877 Wertheim  
Germany

Tel.: +49 9342 808-0

Fax: +49 9342 808-5555

E-Mail: [info@vacuubrand.com](mailto:info@vacuubrand.com)

Web: [www.vacuubrand.com](http://www.vacuubrand.com)



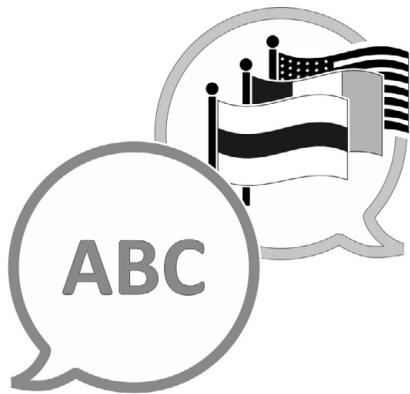

[VACUUBRAND > Support > Manuals](#)

Manufacturer:

**VACUUBRAND GMBH + CO KG**  
**Alfred-Zippe-Str. 4**  
**97877 Wertheim**  
**GERMANY**

Phone:

Head office +49 9342 808-0  
Sales +49 9342 808-5550  
Service +49 9342 808-5660

Fax: +49 9342 808-5555

Email: [info@vacuubrand.com](mailto:info@vacuubrand.com)

Web: [www.vacuubrand.com](http://www.vacuubrand.com)