

MVP 070-3



MVP 070-3, diaphragm pump, 100–230 V, 50/60 Hz

- Diaphragm pump with a pumping speed of up to 4.3 m³/h
- No hydrocarbons: Completely dry & oil-free diaphragm pump
- Low noise level, minimal vibrations and compact design, ideal also for use in laboratories
- Low operating costs thanks to the highest quality, short maintenance times and long maintenance intervals
- Simple logistics: Our diaphragm pumps are suitable for all voltages worldwide
- Fulfills cleanroom class ISO 8 (according to DIN EN ISO 14644-1)

Characteristics

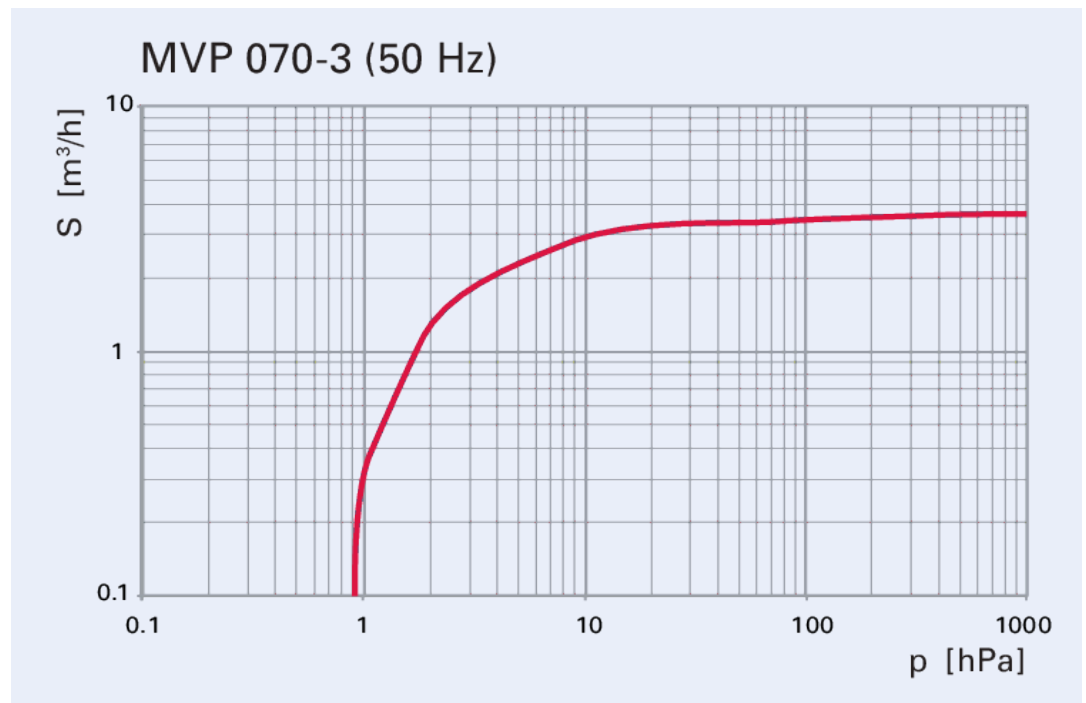

Dimensions

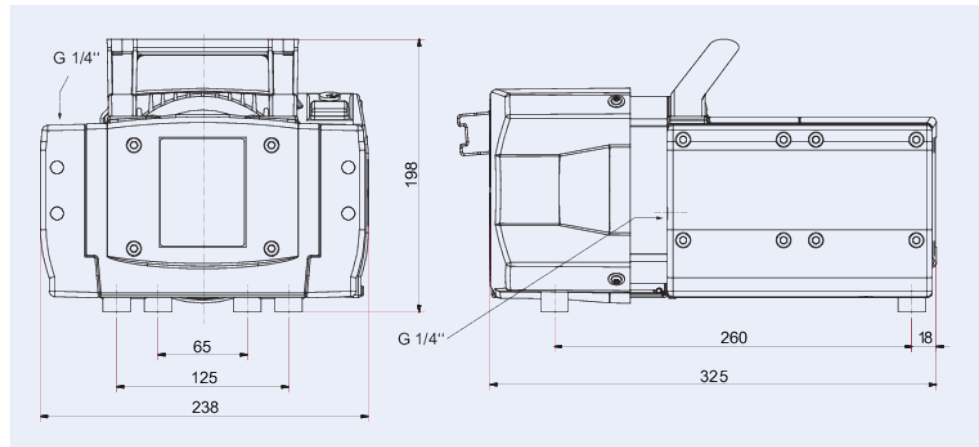

Technical Data	MVP 070-3, diaphragm pump, 100–230 V, 50/60 Hz
Pumping speed at 50 Hz	3.8 m ³ /h 2.23668 cfm 63.3346 l/min
Pumping speed at 60 Hz	4.3 m ³ /h 2.53098 cfm 71.6681 l/min
Ultimate pressure	1 · 10 ⁰ hPa 7.5 · 10 ⁻¹ Torr 1 · 10 ⁰ mbar
Integral leak rate	2 · 10 ⁻³ Pa m ³ /s 2.66 · 10 ⁻¹ Torr l/s 2 · 10 ⁻¹ mbar l/s
Intake pressure max.	1,100 hPa 825 Torr 1,100 mbar
Exhaust pressure, max.	1,100 hPa 825 Torr 1,100 mbar
Connection flange (in)	G ¼"
Connection flange (out)	G 1/4"
Input voltage(s)	100 – 115 / 200 – 230 V AC, 50 Hz 100 – 115 / 120 / 200 – 230 V AC (±10 %), 60 Hz
Input voltage: tolerance	±10 %
Motor type	1-phase motor
Protection degree	IP40
Certification	cTUVus certified according to UL / CSA 61010-1
Switch	Yes
Emission sound pressure level (EN ISO 2151)	52 dB(A)
Ambient temperature	10 – 40 °C
Temperature: Storage	-10 – 60 °C
Temperature: Shipping	-10 – 60 °C
Cooling method	Air (Forced convection)
Weight	16.4 kg 36.16 lb
Gas ballast	No
Operating altitude, max.	2,000 m

Order number	MVP 070-3, diaphragm pump, 100–230 V, 50/60 Hz
MVP 070-3, diaphragm pump, 100–230 V, 50/60 Hz	PK 052 004 -T

Accessories	MVP 070-3, diaphragm pump, 100–230 V, 50/60 Hz
Housing cover for MVP 070-3 (inlet)	PK 050 197
Housing cover for MVP 070-3 (outlet)	PK 050 198
Elbow union for MVP 035-160 1/4" thread	P 0920 813
Fuse set for MVP 040/070 (C)	PU E22 016 -T
Spare part package fan for MVP 040/070 (C)	PU E22 019 -T