

HiCube 300 Neo



HiCube 300 Neo, DN 100 CF-F, MVP 030-3

- Compact series of pumping stations for all high vacuum applications
- Simple operation with touch display
- Remote control via web server available
- Reliable and robust

Dimensions

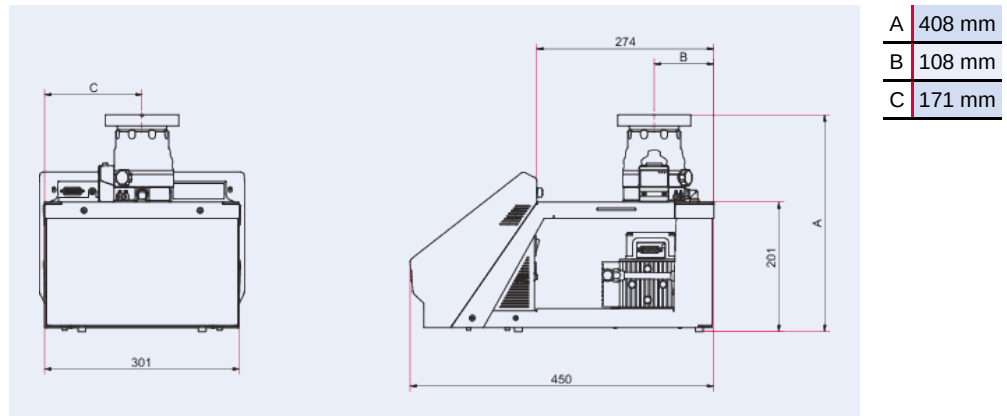

Technical Data

HiCube 300 Neo, DN 100 CF-F, MVP 030-3

Cooling method	Air (Forced convection)
Pumping speed backing pump	50 Hz: 1.8 m ³ /h
Motor for region	Worldwide
Type	Turbo pumping station
Turbopump	HiPace 300
Ambient temperature	5 – 40 °C
Rated power at max. rotation speed	235 W
Input voltage(s)	100 – 120 / 200 – 240 V AC (±10 %), 50/60 Hz
Emission sound pressure level (EN ISO 2151)	≤50 dB(A)
Pumping speed for N ₂	260 l/s
Weight	22.5 kg 49.6 lb
Backing pump	MVP 030-3
Fore-vacuum safety valve	No
Connection flange (in)	DN 100 CF-F
Connection flange (out)	Silencer, 1/8" thread

Order number

HiCube 300 Neo, DN 100 CF-F, MVP 030-3

HiCube 300 Neo, DN 100 CF-F, MVP 030-3

PM Q121 011 00