

Peltier-cooled incubator IPP55plus

Microbiology, zoology, food, cosmetics or pharma industry: the energy-saving cooled incubator with Peltier elements heats up and cools down seamlessly in one system.

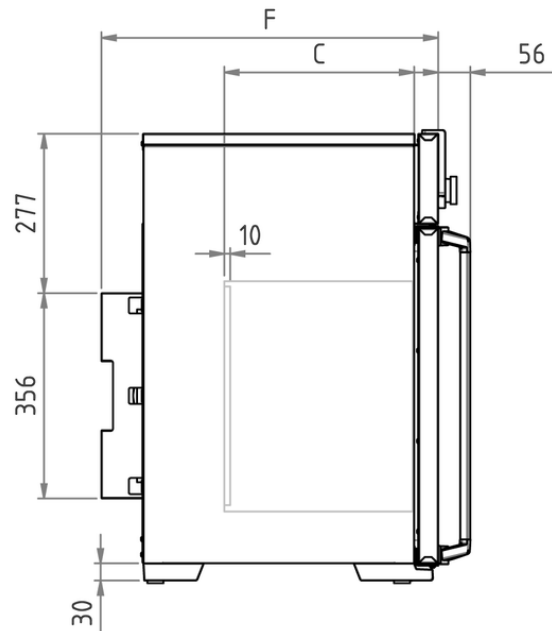

With the help of our model selection, with dimensioned model sketches and extensive technical data for download, you will find your perfect Peltier-cooled incubator. For large volumes in conjunction with rapid temperature changes, the Memmert compressor-cooled incubator is recommended. Flexibility and technical features of our appliances meet all possible needs. Put us to the test!

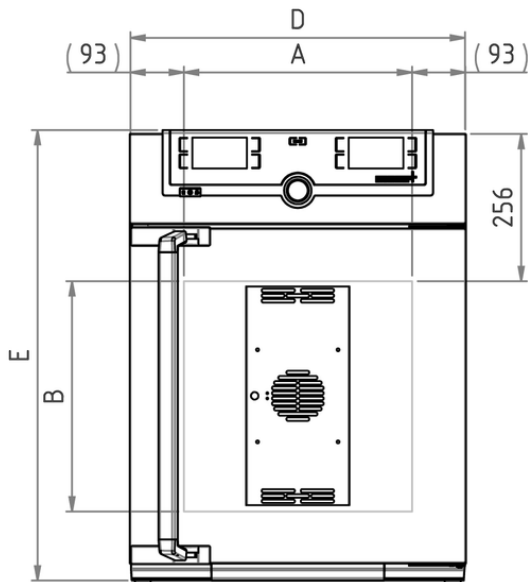

Temperature

Setting temperature range	0 to +70 °C
Working temperature range	without light: from 0 (at least 20 below ambient temperature) to +70°C
Setting resolution temperature	0.1 °C
Temperature sensor	2 Pt100 sensors DIN Class A in 4-wire-circuit for mutual monitoring, taking over functions in case of an error

Control technology

ControlCOCKPIT	TwinDISPLAY. Adaptive multifunctional digital PID-microprocessor controller with 2 high-definition TFT-color displays.
Language setting	German, English, Spanish, French, Polish, Czech, Hungarian
Timer	Digital backwards counter with target time setting, adjustable from 1 minute to 99 days
Function SetpointWAIT	the process time does not start until the set temperature is reached
Calibration	three freely selectable temperature values
adjustable parameters	temperature (Celsius or Fahrenheit), timer

Ventilation

Convection	forced ventilation by Peltier fan
-------------------	-----------------------------------

Communication

Documentation	program stored in case of power failure
Programming	AtmoCONTROL software on a USB stick for programming, managing and transferring programs via Ethernet interface or USB port

Safety

Temperature control	over- and undertemperature monitor TWW, protection class 3.3 or adjustable temperature limiter TWB, protection class 2, selectable on display
AutoSAFETY	additionally integrated over- and undertemperature protection "ASF", automatically following the setpoint value at a preset tolerance range, alarm in case of over- or undertemperature, heating function is switched off in case of overtemperature, cooling function in case of undertemperature
Autodiagnostic system	for fault analysis
Alarm	visual and acoustic

Heating concept

Peltier	Heating and cooling performance distribution by individual control of the Peltier elements in the upper and lower row
Peltier	energy-saving Peltier heating-/cooling system integrated in the rear (heat pump principle)

Standard equipment

Door	fully insulated stainless steel door with 2-point locking (compression door lock)
Shelving	1 stainless steel grids, electropolished
Works calibration certificate	for +10°C and +37°C
Door	inner glass door

Stainless steel interior

Dimensions	$w_{(A)} \times h_{(B)} \times d_{(C)}$: 15.7 x 15.7 x 13 inches (d less 0.4" for fan - Peltier)
Volume	53 l / 1.9 cu ft
Max. number of shelves	4
Max. loading of chamber	176 lbs
Max. loading per shelf	44 lbs

Textured stainless steel casing

Dimensions	$w_{(D)} \times h_{(E)} \times d_{(F)}$: 23 x 30.9 x 23.1 inches (d +2.2" door handle)
Housing	rear zinc-plated steel

Electrical data

Voltage	230 V ($\pm 10\%$), 50/60 Hz
Electrical load	approx. 275 W / 1.2 A
Voltage	115 V ($\pm 10\%$), 50/60 Hz
Electrical load	approx. 275 W / 2.4 A

Ambient conditions

Set Up	The distance between the wall and the rear of the appliance must be at least 6". The clearance from the ceiling must not be less than 8" and the side clearance from walls or nearby appliances must not be less than 5 cm.
Ambient temperature	16 °C to 40 °C
Humidity rh	max. 70 %, non-condensing
Altitude of installation	max. 2,000 m above sea level
Overvoltage category	II
Pollution degree	2

Packing/shipping data

Transport information	The appliances must be transported upright
Customs tariff number	8419 8998
Country of origin	Federal Republic of Germany
WEEE-Reg.-No.	DE 66812464
Dimensions approx incl. carton	w x h x d: 29 x 38 x 27 inches
Net weight	approx. 115 lbs
Gross weight carton	approx. 157 lbs

Standard units are safety-approved and bear the test marks

