

Incubator

IN750

The incubator I is at home everywhere in the world of research, medicine, pharmaceuticals and food analytics, as well as food chemistry.



The heating of this incubator is optimally tuned for natural convection and valuable chamber loads for research, pharmaceuticals, medicine and food chemistry are warmed up very carefully. On this page, you can find all the essential technical data on our incubator. Our customer relations team will be pleased to help if you want further information. If you should require a customized special solution, please contact our technical specialists at info@memmertusa.com.

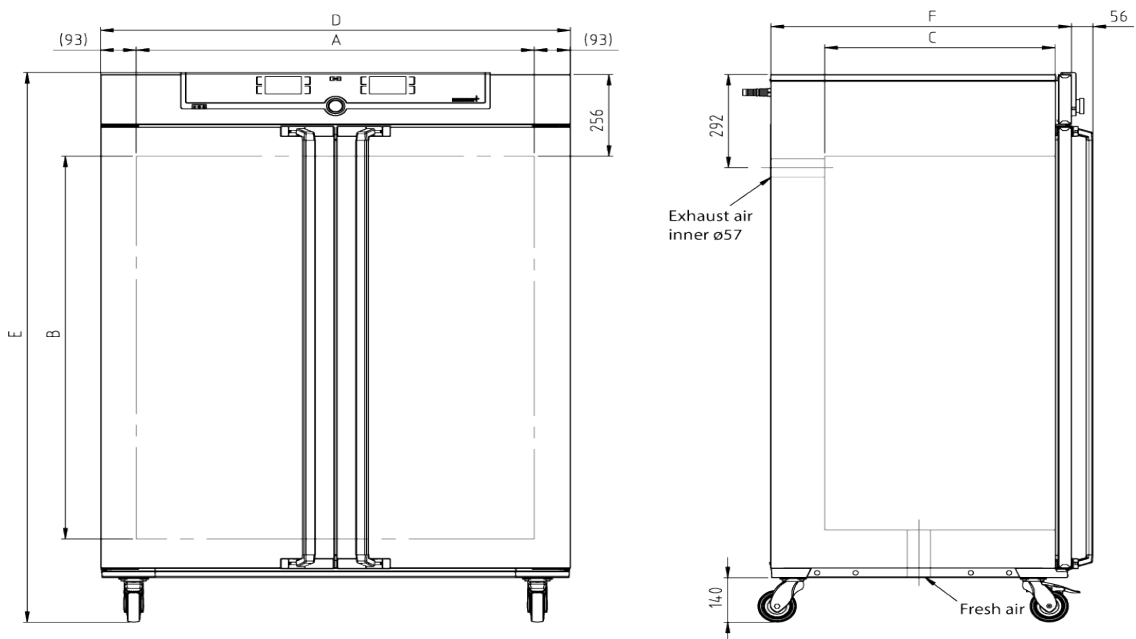

Temperature

Setting temperature range	+20 to +80 °C
Working temperature range	at least 5 above ambient temperature to +80 °C
Setting resolution temperature	0.1 °C
Temperature sensor	1 Pt100 sensor DIN class A in 4-wire-circuit

Control technology

Language setting	German, English, Spanish, French, Polish, Czech, Hungarian
ControlCOCKPIT	SingleDISPLAY. Adaptive multifunctional digital PID-microprocessor controller with high-definition TFT-color display
Timer	Digital backwards counter with target time setting, adjustable from 1 minute to 99 days
Function SetpointWAIT	the process time does not start until the set temperature is reached
Calibration	three freely selectable temperature values
adjustable parameters	temperature (Celsius or Fahrenheit), air flap position, timer

Ventilation

Convection	natural convection
Fresh air	Admixture of pre-heated fresh air by electronically adjustable air flap
Vent	vent connection with restrictor flap

Communication

Documentation	settings stored in case of power failure
Data logging	AtmoCONTROL software for reading out, managing and organizing the data logger via Ethernet interface (temporary trial version can be downloaded). USB stick with AtmoCONTROL software available as accessory (on demand).

Safety

Temperature control	adjustable electronic overtemperature monitor and mechanical temperature limiter TB, protection class 1 according to DIN 12880 to switch off the heating approx. 20°C above nominal temperature
Autodiagnostic system	for fault analysis

Standard equipment

Shelving	2 stainless steel grids, electropolished
Works calibration certificate	incl. works calibration certificate for +37°C
Door	inner glass doors
Door	fully insulated stainless steel doors with 2-point locking (compression door lock)

Stainless steel interior

Interior	easy-to-clean interior, made of stainless steel, reinforced by deep drawn ribbing with integrated and protected large-area heating on four sides
Volume	749 l / 26.5 cu ft
Dimensions	$w_{(A)} \times h_{(B)} \times d_{(C)}$: 40.9 x 47.2 x 23.6 inches
Max. number of shelves	14
Max. loading of chamber	661 lbs
Max. loading per shelf	66 lbs

Textured stainless steel casing

Dimensions	$w_{(D)} \times h_{(E)} \times d_{(F)}$: 48.2 x 67.7 x 30.9 inches (d +2.2" door handle)
Installation	on lockable castors
Housing	rear zinc-plated steel

Electrical data

Voltage	230 V ($\pm 10\%$), 50/60 Hz
Electrical load	approx. 2000 W / 8.7 A
Voltage	115 V ($\pm 10\%$), 50/60 Hz
Electrical load	approx. 1800 W / 15.7 A

Ambient conditions

Set Up	The distance between the wall and the rear of the appliance must be at least 6". The clearance from the ceiling must not be less than 8" and the side clearance from walls or nearby appliances must not be less than 2".
Altitude of installation	max. 2,000 m above sea level
Ambient temperature	+5 °C to +40 °C
Humidity rh	max. 80 %, non-condensing
Overvoltage category	II
Pollution degree	2

Packing/shipping data

Transport information	The appliances must be transported upright
Customs tariff number	8419 8998
Country of origin	Federal Republic of Germany
WEEE-Reg.-No.	DE 66812464
Dimensions approx incl. carton	w x h x d: 53 x 76 x 42 inches
Net weight	approx. 479 lbs
Gross weight carton	approx. 635 lbs

Standard units are safety-approved and bear the test marks

