



Compressor-cooled incubator ICP110

Do you require different ramps for incubating, breeding or storing? Do you need a larger chamber volume and at the same time quick temperature changes?



With the help of our model selection, with dimensioned model sketches and extensive technical data for download, you can find the right cooled incubator for your needs. For small volumes and for work predominantly in the proximity of the ambient temperature, the Memmert Peltier-cooled incubator is recommended. Flexibility and technical features of our appliances meet all possible needs. Put us to the test!

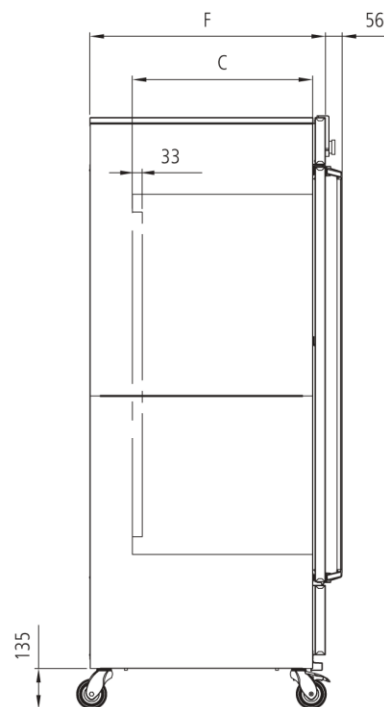
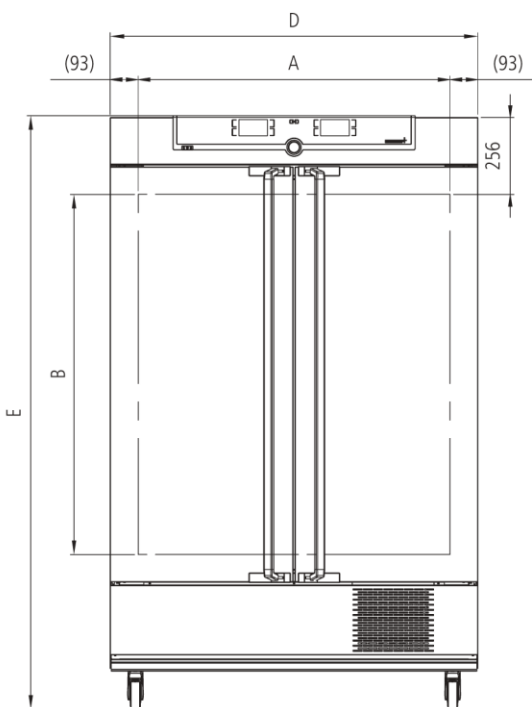

Control of standard components

Control	COCKPIT	adaptive multifunctional digital PID-microprocessor controller with 2 high-definition TFT-color displays
Temperature		2 Pt100 sensors Class A in 4-wire-circuit, mutually monitoring and taking over the performance at the same temperature value
Timer		Digital backwards counter with target time setting, adjustable from 1 minute to 99 days

Temperature

		from -12°C up to +60°C (optimum performance of cooling aggregate at an ambient temperature of +16°C up to +32°C)
resolution of display for setpoint and actual temperature values		0.1°C

Control technology

adjustable parameters		temperature (Celsius or Fahrenheit), fan speed, program time, time zones, daylight savings time
Function Setpoint	WAIT	the process time does not start until the set temperature is reached
Language setting		German/English/Spanish/French
Calibration		three freely selectable temperature values

Ventilation

Fan		forced air circulation in working chamber adjustable from 10 to 100 % in 10 % steps
------------	--	---

Communication

Programming		AtmoCONTROL software on a USB stick for programming, managing and transferring programs via Ethernet interface or USB port
Documentation		program stored in case of power failure

Safety

Autodiagnostic system		for fault analysis
Alarm		audible and visual
Temperature control		over- and undertemperature monitor TWW, protection class 3.3 or adjustable temperature limiter TWB, protection class 2, selectable on display
AutoSAFETY		additionally integrated over- and undertemperature protection "ASF", automatically following the setpoint value at a preset tolerance range, alarm in case of over- or undertemperature, heating is switched off in case of overtemperature, compressor in case of undertemperature
Temperature control		mechanical temperature limiter TB, protection class 1 according to DIN 12880 to switch off the heating approx. 10°C above nominal temperature

Heating concept

no drying-up of the load caused by the cooling device due to separation of thermal jacket from interior

energy-saving use of CFC-free cooling/heating system (refrigerant R134a)

highly efficient automatic defrosting system

air jacket heating system for gentle all-around heating

Standard equipment

Door fully insulated stainless steel door with 2-point locking (compression door lock)

Door inner glass door

Internals 2 stainless steel grids

Scope of delivery incl. works calibration certificate for +10°C and +37°C

Housing rear zinc-plated steel

Installation on lockable castors

Stainless steel interior

$w_{(A)} \times h_{(B)} \times d_{(C)}$: 22" x 18.9" x 15.8"

Volume 108 l

Max. loading of chamber: 331 lbs

Textured stainless steel casing

$w_{(D)} \times h_{(E)} \times d_{(F)}$: 29.3" x 48.5" x 23"

Electrical data

115 V (+/- 10%), 50/60 Hz / approx. 10.4 amps

230 V (+/- 10%), 50/60 Hz / approx. 5.0 amps

Packing/shipping data

the appliances must be transported upright

Customs tariff number 8419 8998

Country of origin Federal Republic of Germany

WEEE-Reg.-No. DE 66812464

Dimensions approx. incl. carton B x H x T: 34.7" x 55.5" x 31.9"

Net weight approx. 249 lbs

Gross weight carton approx. 311 lbs