



**LABCONCO CORPORATION** 8811 Prospect Ave, Kansas City, MO 64132  
(816) 333-8811 or (800) 821-5525 • (816) 363-0130 fax • labconco.com

## Labconco Small Tray Dryer Instructions (7807010xx Series)

*Note: This instruction sheet may not provide all the information necessary to run your Freeze Dry System. Refer to the FreeZone® Freeze Dryer User's Manual for details and precautions.*

### Intended Use

The Small Bulk Tray Dryer is intended to be used in conjunction with Labconco Freeze Dryers in a laboratory setting to facilitate the lyophilization process.

## Preparations

### Proper Electrical Supply

- 115V models
  - Power requirement: 5 Amp, single phase
  - Properly grounded receptacle for NEMA 5-15P plug.



US  
(NEMA 5-15P)

- 230V models
  - Power requirement: 2.5 Amp, single phase
  - Properly grounded receptacle that matches the plug supplied with the unit (230V models are supplied with one of the following plugs):



US  
(NEMA 6-15P)

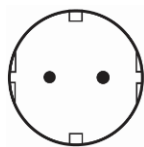

EU



China



UK



India

- If the plug does not match the available receptacle, remove the plug and replace it with an approved plug of the suitable style.



**Do not use any detachable power cord that is not adequately rated for the unit.**

## Installation

- Remove the shelves to reduce the weight of the Tray Dryer.
- Close and latch the door.
- With the help from an assistant, lift the Tray Dryer onto the freeze dryer. Make sure that the gasket on the Tray Dryer is resting on the top lip of the chamber.

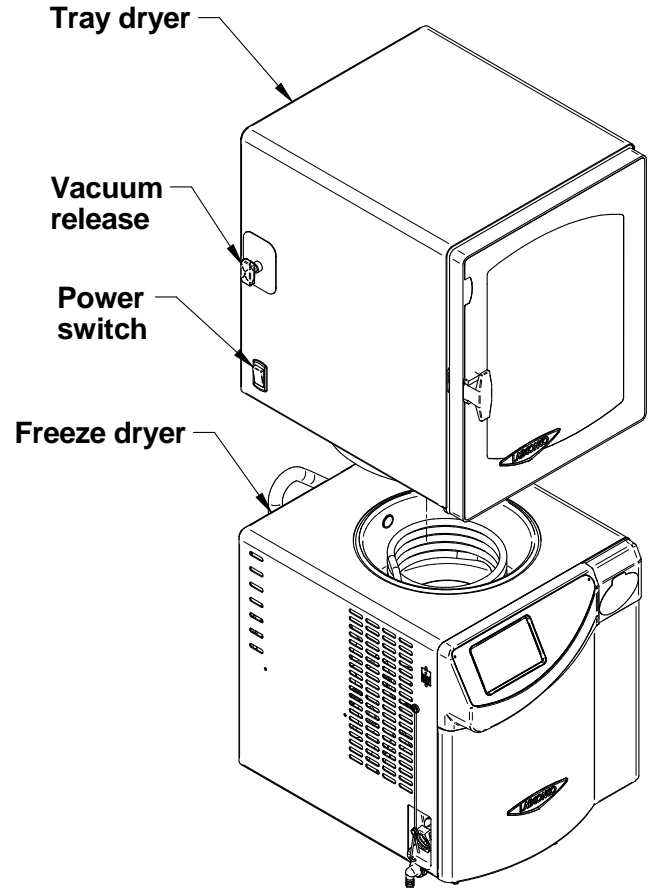

### Anti-tip Bracket (2.5L Model Only)

- Remove the top two #10-24 screws on the freeze dryer shown below.
- Attached the anti-tip bracket to the freeze dryer as shown. The slots in the top of the bracket will line up with the two threaded pins on the back of the tray dryer. Screw the two knobs into these threaded pins.

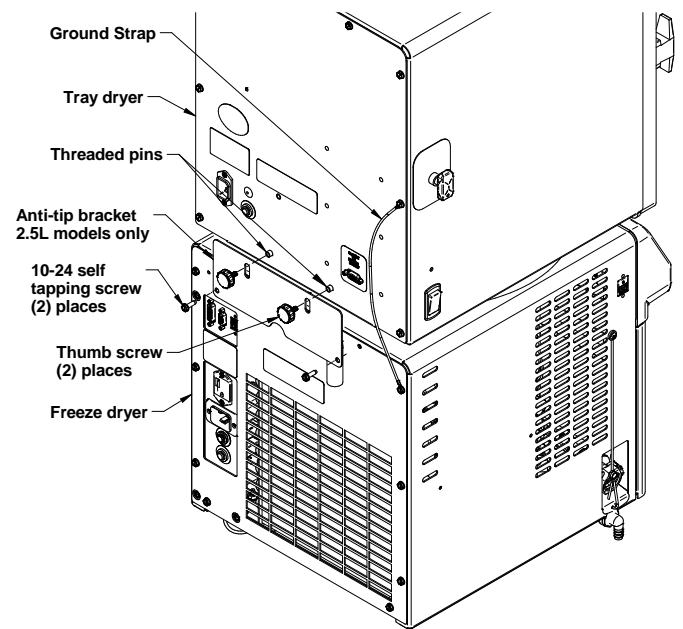

## Accessory Port Stopper (Console Models Only)

- If accessory port is not being used, placed supplied #8 stopper in accessory port hole to seal vacuum system.

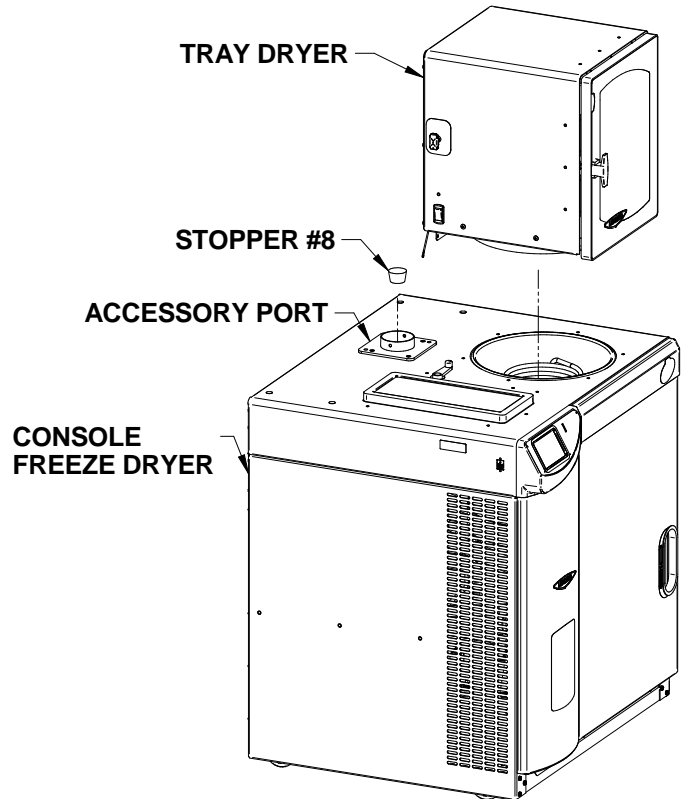

## Electrical Connection

Plug the power cord into the receptacle on the back of the Tray Dryer and plug the other end into a suitable power receptacle. Make sure that the outlet that you intend to use meets the voltage and amperage requirements listed on the serial tag of the Tray Dryer.



**Do not attempt to plug the power cord from the Tray Dryer into the Freezone Freeze Dryer.**

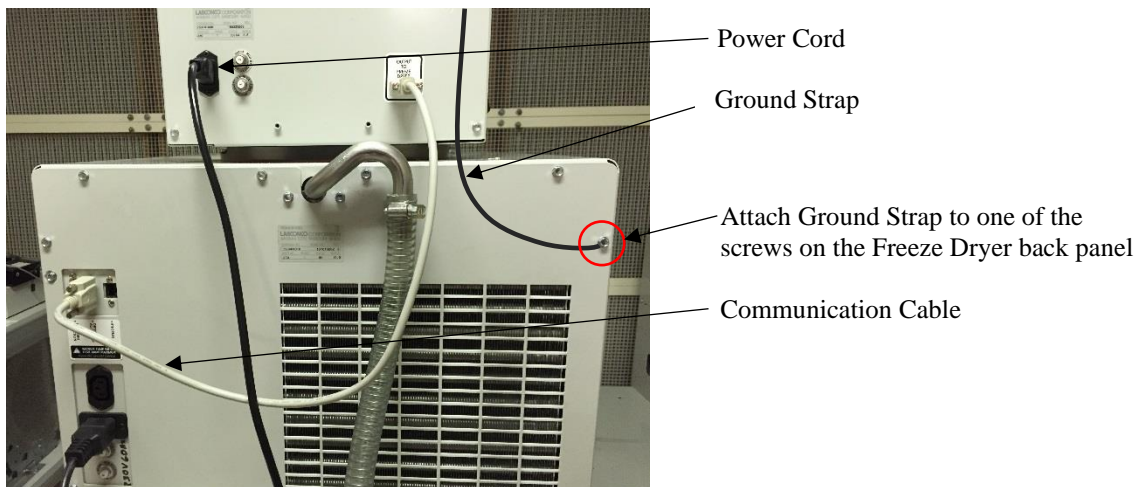

## Communication Cable

The Freeze Dryer power cord should be unplugged before connecting the communication cable. Connect one end of the communication cable (7364600) to the port on the back panel of the Tray Dryer labeled “OUTPUT TO FREEZE DRYER”. Connect the other end of the cable to the port on the Freeze Dryer labeled “DRYING ACCESSORY”. Plug the Freeze Dryer power cord back into a suitable power receptacle.

## Ground Strap

The Tray Dryer comes with a ground strap attached to the back panel. Remove one of the screws from the back panel of the Freeze Dryer and attach the other end of the ground strap to the Freeze Dryer.

## Sample Probes

Connect the sample probes into the receptacles in the front of the shelves.



## Testing and Start Up

### Test System

- Turn ON the Freeze Dryer base unit and let the collector reach  $-40^{\circ}\text{C}$  or below.
- Close and latch the Tray Dryer door.
- Make sure the VAC RELEASE valve is set to CLOSE.
- Start the vacuum pump. Vacuum in the system should reach at least 0.133 mbar within 30 minutes and 0.040 mbar within 18 hours.

## Tray Dryer Controls

1. **Power Switch**- Located on left side of cabinet turns the unit on or off.
2. **Vacuum Release Valve**- Located on left side of cabinet vents the chamber so the chamber door can be opened.
3. **Status indicators**– Power/Standby indicator shows if the Tray Dryer is powered on and ready. The In Process indicator shows when the Tray Dryer is actively running a process (in Manual or Program mode).

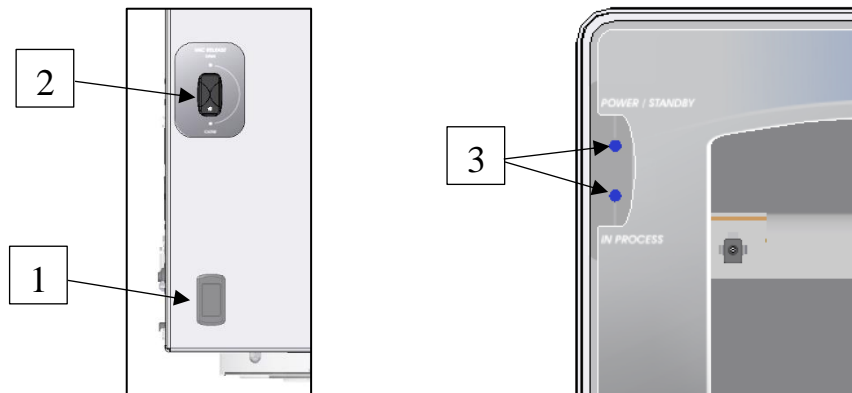

## Operation Checklist

The checklist below should be followed prior to each use of your Tray Dryer.

1. Wipe out the interior of the Tray Dryer chamber with a soft cloth or paper towel to remove any moisture or debris.
2. Ensure that the Freeze Dryer collector chamber and drain line are free of water. Place the drain hose in a suitable container to collect the condensate from the collector chamber. Insert the quick connect drain fitting into the quick connect drain coupling. **Note: Freeze Dryer (Collector or Vacuum) will not start if moisture is detected in the drain line.**
3. After completely draining the system, disconnect the quick connect drain fitting from the quick connect drain coupling.

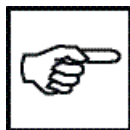

**DISCONNECT THE QUICK CONNECT DRAIN FITTING BEFORE STARTING THE VACUUM PUMP. FAILURE TO REMOVE THE FITTING WILL RESULT IN A LARGE VACUUM LEAK.**

4. Remove the shelves in the Tray Dryer to access the Freeze Dryer's collector chamber. Wipe the interior of the collector chamber with a soft cloth or paper towel to remove any accumulated moisture.
5. Using a soft, lint-free cloth or paper towel, wipe the Tray Dryer door gasket to remove any dirt and contaminants that could cause a vacuum leak. Vacuum grease is not required on the door gasket to obtain a proper vacuum seal, but may be used if desired.

## Operating the Tray Dryer

1. Adjust the shelf spacing - Prior to loading the shelves with the product to be freeze dried, adjust the shelf spacing to accommodate the size and quantity of the samples. The Tray Dryer comes equipped with three heated shelves and two additional accessory shelves may be added. At least one shelf must be used and any number of shelves up to five may be used. Shelves may be connected at any of the five available positions. Be certain to push the shelf to the back of the chamber until the electrical connector is fully engaged to ensure a positive electrical connection to the heaters.
2. Temperature Sensors – Each shelf is equipped with a “Shelf” sensor that is used to accurately control the temperature of the shelf. A “Sample” sensor can also be plugged into the two pin connector at the front of the shelf that can be used to monitor the sample temperature during the freeze drying process. The sensors will be displayed as Shelf 1, 2, 3, 4, & 5 and Sample 1, 2, 3, 4, & 5 on the Freeze Dryer display Screen.
3. Freeze the Sample - Before the freeze dry process can occur the product must be in a frozen state. This must be done in a freezer separate from the Tray Dryer.
4. Start the Freeze Dryer - Turn ON the Freeze Dryer COLLECTOR (See Freeze Dryer User’s Manual).
5. Turn ON the Tray Dryer by toggling the power switch located on the left side of the unit. The POWER/STANDBY LED on the front of the unit will turn ON.
6. Position the Vacuum Release valve to CLOSE.
7. Load Samples- Position samples on the shelves inside the Tray Dryer. Close the door and rotate the handle 180° to latch the door. **SAMPLE SHOULD BE LOADED AFTER THE FREEZE DRYER COLLECTOR TEMPERATURE REACHES –40°C OR BELOW.** If the collector is not cold when the samples are loaded (and the freeze dry process is started), then water vapor will bypass the collector and go into the vacuum pump. This will contaminate the pump oil and can cause premature failure of the vacuum pump.
8. Turn ON the vacuum pump.
9. Start the Tray Dryer in either MANUAL or PROGRAM mode to control the shelf temperature to a set point value.

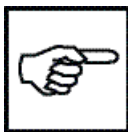

ALL ELECTRONIC CONTROL OF THE TRAY DRYER WILL BE DONE BY USING THE TOUCH SCREEN DISPLAY ON THE FREEZE DRYER BELOW THE TRAY DRYER.

The main features that are used to control the Tray Dryer will be described below. For a complete description of the Freeze Dryer operating system, consult the Freeze Dryer User’s Manual.

## Drying Accessory Screen

If the Tray Dryer is NOT connected to the Freeze Dryer (via the communication cable), the Drying Accessory icon will NOT appear in the main menu bar. If the Tray Dryer has been properly connected to the Freeze Dryer, the Drying Accessory icon will appear in the main menu bar and you will be able to control and monitor the Drying Accessory from this screen.

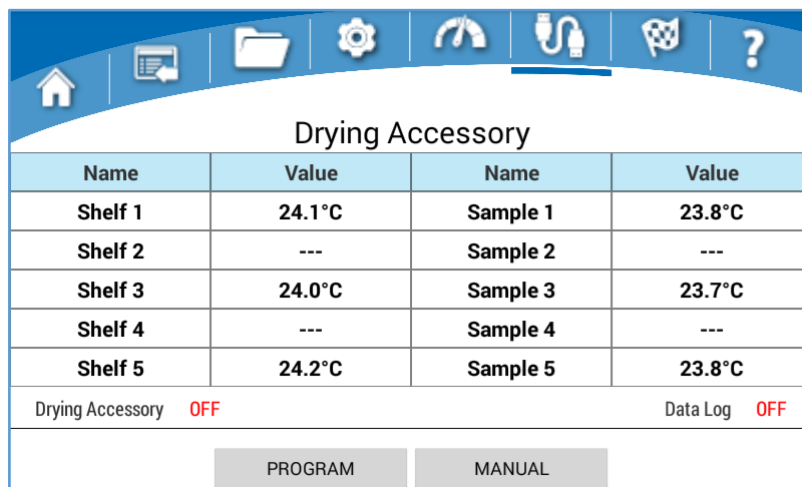

Drying Accessory			
Name	Value	Name	Value
Shelf 1	24.1°C	Sample 1	23.8°C
Shelf 2	---	Sample 2	---
Shelf 3	24.0°C	Sample 3	23.7°C
Shelf 4	---	Sample 4	---
Shelf 5	24.2°C	Sample 5	23.8°C
Drying Accessory <b>OFF</b>		Data Log <b>OFF</b>	
PROGRAM		MANUAL	

**Drying Accessory Sensor Table** – The middle section of the screen displays a list of all the sensors that are available for the connected Drying Accessory. Sensors that are disconnected will have three dashes (---) for their value.

**Drying Accessory Status Box** – The status box is located directly below the sensor table. The text on the left side will indicate the current operation mode of the Drying Accessory (OFF, Manual, or Program). When in Manual mode, the word “Manual” and the current Shelf Temp Set Point value will be displayed in this location. If a program is running the program name, Step #, and Time Remaining (TR) in the current Step will be displayed in this location. The right side of the status box will indicate if Data Logging is currently ON or OFF.

- **PROGRAM** – Pressing this button will take you to the Programs screen, where you can create a new program, or start, edit, view, copy or delete a saved program.
- **MANUAL** – Use this button to enter a Shelf Temp Set Point and/or start the Drying Accessory in manual mode.

## Manual Mode

Manual mode can be used to control the shelf temperature to a single set point value between -20°C and +60°C.

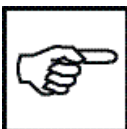

THE SHELVES HAVE NO COOLING MECHANISM, THEREFORE ANY COOLING BELOW ROOM TEMPERATURE IS DONE BY THE FROZEN SAMPLES AND THE COOLING FROM THE SUBLIMATION PROCESS THAT IS OCCURRING.

**Primary Drying Phase** - Allow the vacuum to pull down to the desired value. Start the Tray Dryer in MANUAL mode. At no time during the primary drying phase should the product temperature be allowed to rise above the eutectic temperature. The set point temperature should be lower than the eutectic temperature of the sample. If the eutectic temperature is below  $-20^{\circ}\text{C}$ , do not set the heater temperature for primary drying and do not start the Tray Dryer (in Manual or Program mode).

**Secondary Drying Phase** - After all the free moisture is removed in the primary drying phase, the temperature may be increased for the secondary drying phase.

## Starting MANUAL mode

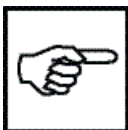

BEFORE STARTING THE TRAY DRYER, ENSURE THAT THE COLLECTOR IS “ON” AND HAS COOLED TO  $-40^{\circ}\text{C}$  OR BELOW.

1. Turn the Tray Dryer power switch ON. The POWER / STANDBY LED Indicator will turn ON.
2. On the Freeze Dryer display, go to the Drying Accessory screen
3. Press the “MANUAL” button
4. Enter a Set Point value between  $-20^{\circ}\text{C}$  &  $+60^{\circ}\text{C}$ , then press “Start”.
5. The IN PROCESS LED Indicator will turn ON.

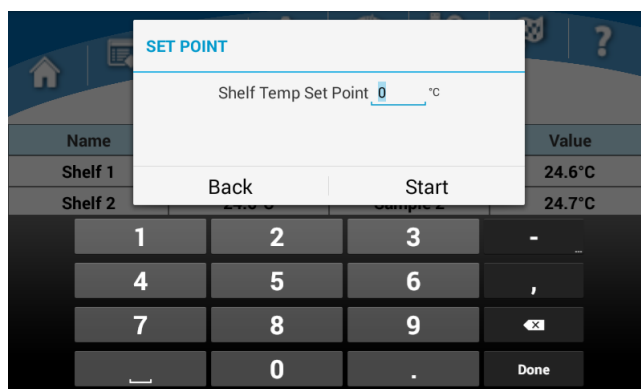

## Changing the Shelf Temp Set Point Value

If the Tray Dryer is already running in MANUAL mode and you want to change the current Shelf Temp Set Point value:

1. Go to the Drying Accessory screen.
2. Press the “MANUAL” button.
3. Enter a new Set Point value and press “Apply”.



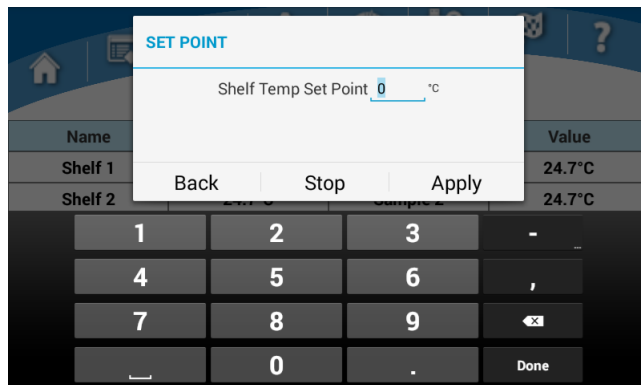

## Stopping MANUAL mode

1. Go to the Drying Accessory screen
2. Press the “MANUAL” button
3. Press the “Stop” button
4. The IN PROCESS LED Indicator will turn OFF.
5. Turn OFF the vacuum pump.
6. Position the “Vac Release” valve to OPEN.
7. Allow the vacuum to bleed to atmospheric pressure, then open the door and remove the samples.
8. Turn OFF the Freeze Dryer collector, defrost the ice, drain the collector chamber and dry.

## Programs

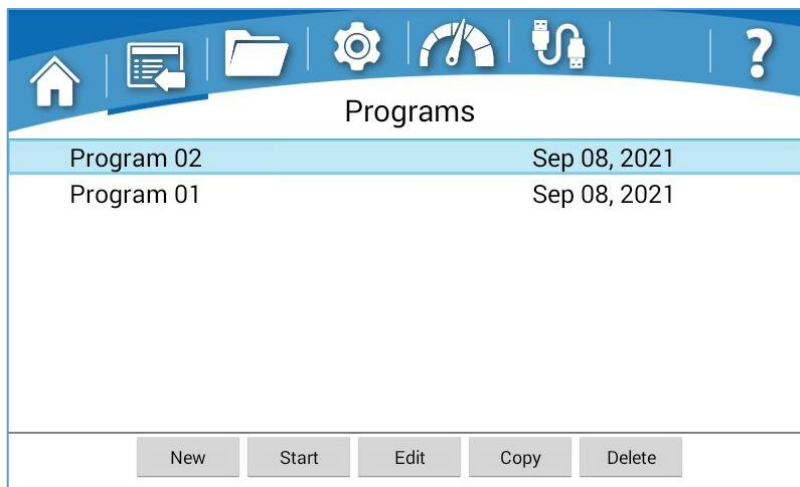

The Programs screen will allow you to create programs that are used to control the shelf temperature and freeze dryer vacuum level. Programs can be designed that take the product through both the primary and secondary drying phases.

When no program has been selected the “New” button will be the only active button along the bottom of the screen. A program can be selected from the program list by pressing the program name. When a program has been selected, the program row will

be highlighted (blue). With a program selected, the rest of the buttons along the bottom of the screen will become active (Start, Edit/View, Copy & Delete).

- **New** – Use this button to add a new program to the program list. The new program name will be defaulted to a two-digit sequential number (starting with “Program 01”) that will be incremented as new programs are added to the list (i.e., Program 02, Program 03...). The default name can be edited as desired in the New or Edit screen.
- **Start/Stop** – Use this button to start or stop a program. The wording on this button will change from “Start” to “Stop” depending on whether a program is currently running.

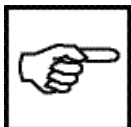

THE TRAY DRYER MUST BE ATTACHED TO THE FREEZE DRYER (VIA THE COMMUNICATION CABLE) TO RUN A PROGRAM. IF IT IS NOT ATTACHED TO THE FREEZE DRYER, THE START BUTTON WILL BE INACTIVE.

- **Edit/View** – Use this button to Edit or View the parameters of a saved program (the wording on this button will change from “Edit” to “View” depending on whether the program is locked or unlocked for editing).
- **Copy** – Use this button to Copy a selected program. The default name will be “*Program Name\_copy*”. The program name can be edited as desired.
- **Delete** – Use this button to delete a saved program from the list.

When a program is currently in progress, a “running man” icon will appear to the left side of the program name. If the running program is selected (highlighted), the “Stop” button will be active, and the “Delete” button will be inactive.

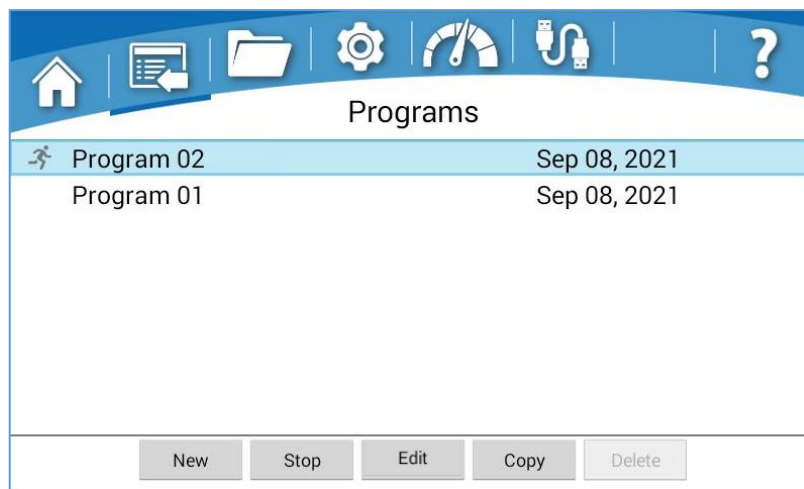

## Creating a New Program

When the “New” button is selected, the following screen will be displayed.



Pressing the program name field will allow you to edit the program name. The “Add” button will add a new Step to the program and take you through a series of screens to set the Shelf Temp., Time, and Vacuum. Values can be edited by pressing any of the cells. Pressing the “Delete” button will delete the selected step from the program. Changes will not be saved until the “Save” button is pressed. Pressing the “Back” button will return to the Programs screen without saving changes.

- **Shelf Temp.** - May be set anywhere from -20°C to +60°C in 1°C increments.
- **Time** – This time represents how long the system will hold at the Shelf Temp. that has been programmed for each Step. The time can be set from 00:01 to 99:59 (1 min to 99 hrs 59 min). It can also be set to an indefinite amount of time, which is represented by the infinity symbol ( $\infty$ ).
- **Vacuum** – Vacuum control can be set from 0.000 to 1.500 mbar.

## Starting a Program



BEFORE STARTING A PROGRAM, ENSURE THAT THE COLLECTOR IS “ON” AND HAS COOLED TO -40°C OR BELOW.

1. Go to the Programs screen. You can access the Programs screen in two different ways, both lead to the same location.
  - a. Directly access the Programs screen by selecting the Programs icon from the main menu bar at the top of the display.
  - b. Go to the Drying Accessory screen, then select the PROGRAM button at the bottom of the screen.
2. Select a program from the saved programs list, or create a new program.
3. With the desired program selected from the list, press the START button.
4. The IN PROCESS LED Indicator will turn ON.

## Stopping a Program

1. At the end of the last programmed step, the Tray Dryer will turn OFF automatically. The IN PROCESS LED Indicator will turn OFF and a “Program Complete” alert will be displayed on the Freeze Dryer touch screen. The Freeze Dryer refrigeration (collector) and vacuum systems will continue to run until they are turned off by the user.
2. To stop the Tray Dryer before the completion of the last programmed step
  - Go to the Programs screen
  - Select (highlight) the program that is currently running
  - Press the STOP button
  - The IN PROCESS LED Indicator will turn OFF
3. Turn OFF the vacuum pump.
4. Position the “Vac Release” valve to OPEN.
5. Allow the vacuum to bleed to atmospheric pressure, then open the door and remove the samples.
6. Turn OFF the Freeze Dryer collector, defrost the ice, drain the collector chamber and dry.

## Maintaining Your Tray Dryer

### Service Safety Precautions



- Always ensure that only authorized technicians service the equipment.
- If performing any electrical maintenance, always disconnect the power at the main disconnect.
- Always practice team lifting when moving heavy equipment.
- After servicing, verify that all access panels or covers are in place before resuming normal operation of the equipment.

### Routine Maintenance Schedule

Under normal operation, the Tray Dryer requires little maintenance. The following maintenance schedule is recommended:

1. The user has the responsibility for carrying out appropriate decontamination if hazardous material is spilled on or inside the equipment. This may be done by wiping the contaminated surfaces with a soft cloth dampened with alcohol. Alcohol may craze the acrylic door. Before using any cleaning or decontamination method except those recommended by Labconco, users should check with Labconco that the proposed method will not damage the equipment.
2. Clean up all spills; remove liquids from the chamber.

3. Clean door and gasket using soft cloth, sponge or chamois and a mild, non-abrasive soap or detergent.

## **Decontamination**

When freeze drying biological substances, it may be necessary to decontaminate the system. A surface decontaminant should be used to clean the accessible surfaces. The use of ethylene oxide is not recommended because of its hazardous and corrosive nature. Contact Labconco for additional information.

## Door Adjustment

The following adjustments can be made if the door is not sealing properly when vacuum is applied.

1. The latch can be adjusted to increase the force between the door gasket and the chamber sealing surface.
  - a. Open the door.
  - b. Using two ½" wrenches loosen the nuts securing the latch pawl.
  - c. Move the latch pawl towards the door to tighten the latch.
  - d. Tighten the nuts.

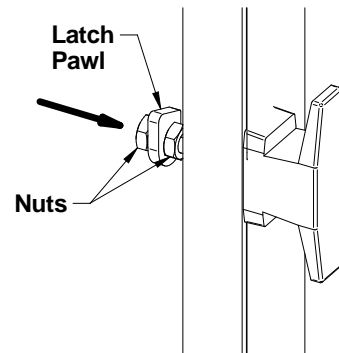

2. The door hinges can be adjusted to move the door in towards the chamber sealing surface.
  - a. Loosen the screws to the hinge covers and rotate the hinge cover out of the way.
  - b. Turn on the vacuum pump using the Freeze Dryer controls.
  - c. After the vacuum level reaches approximately 5 mbar, loosen the six screws on the door hinges. ***Do not remove the screws.***
  - d. Once the vacuum level reaches approximately 1 mbar, tighten the six screws.

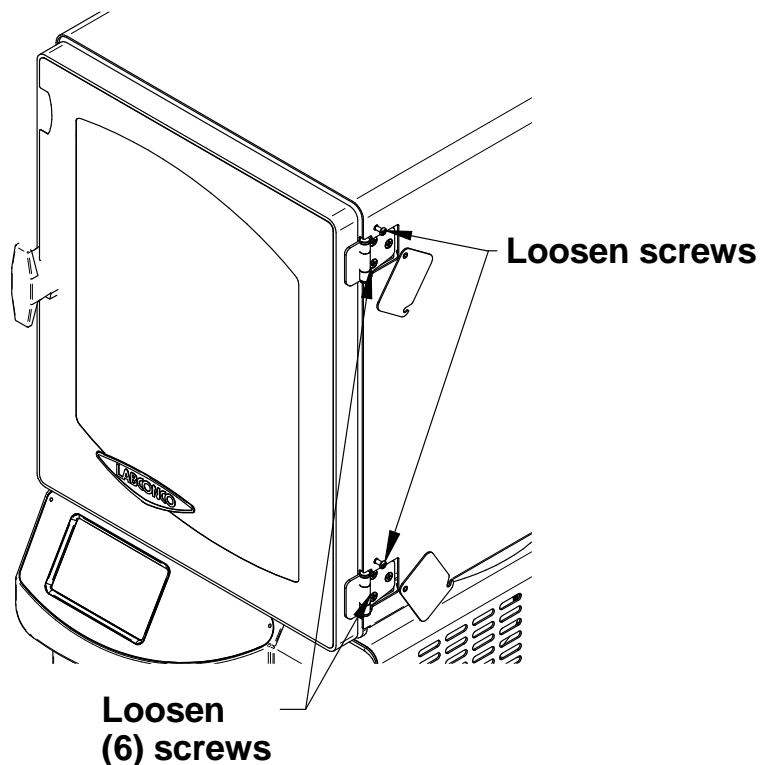

# Tray Dryer Components

The following list of components are available for your Tray Dryer. The parts shown are the most common replacement parts. If other parts are required, contact Labconco Product Service.

Item	Qty	Part No.	Description
1	1	1302301	Switch
2	1	7317000	Printed Circuit Board
3	1	7361900	Pass through
4	1	7344300	Gasket – Pass through
5	1	7378300	Door Assembly
6	1	7378600	Gasket – Door
7	3	7365800	Shelf Probe
8	3	7377400	Shelf with Heater – 115V
		7377401	Shelf with Heater – 230V
9	1	7375700	Gasket Set – Tray Dryer
10	1	7364600	Communication Cable
11	1	1345700	Power Cord 230V 50Hz India
		1332600	Power Cord 230V 50Hz UK
		1332700	Power Cord 230V 50Hz China
		1336100	Power Cord 230V 50Hz EU
		1338000	Power Cord 230V 60Hz US
		1334500	Power Cord 115V 60Hz US

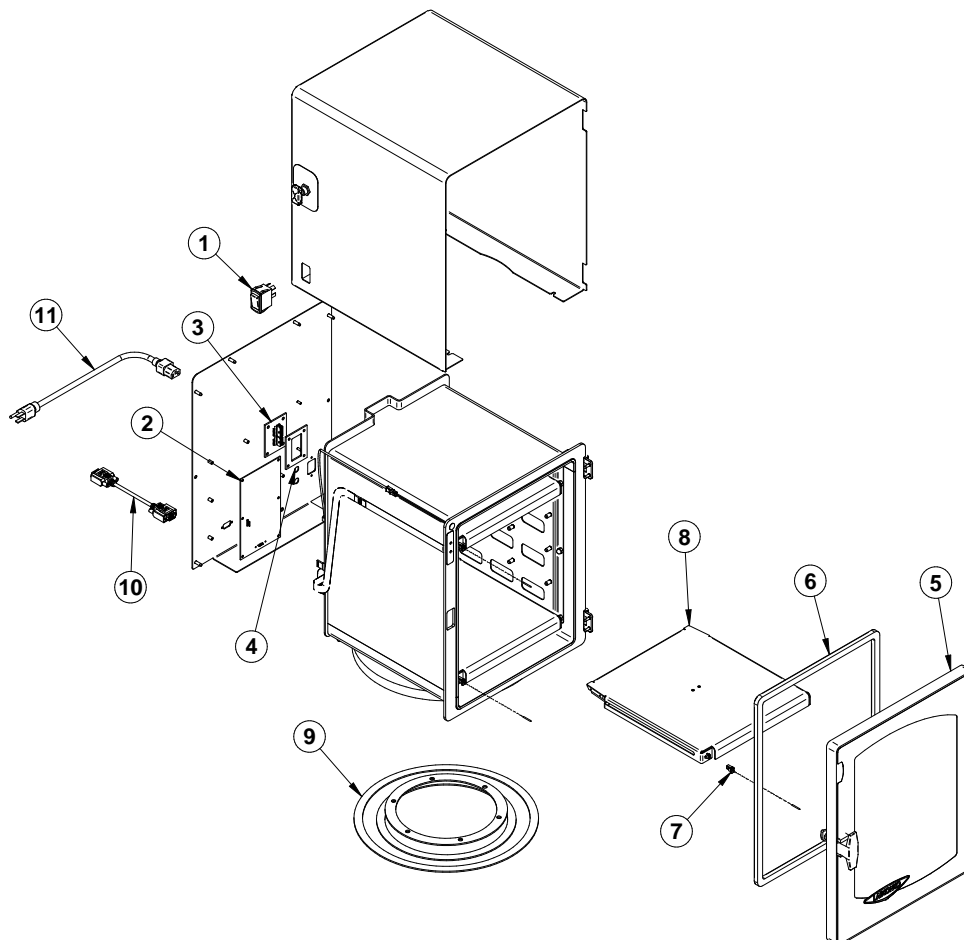

# Tray Dryer Dimensions

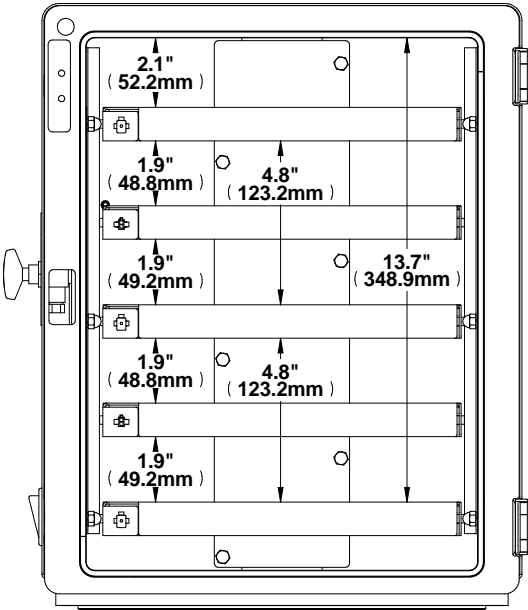
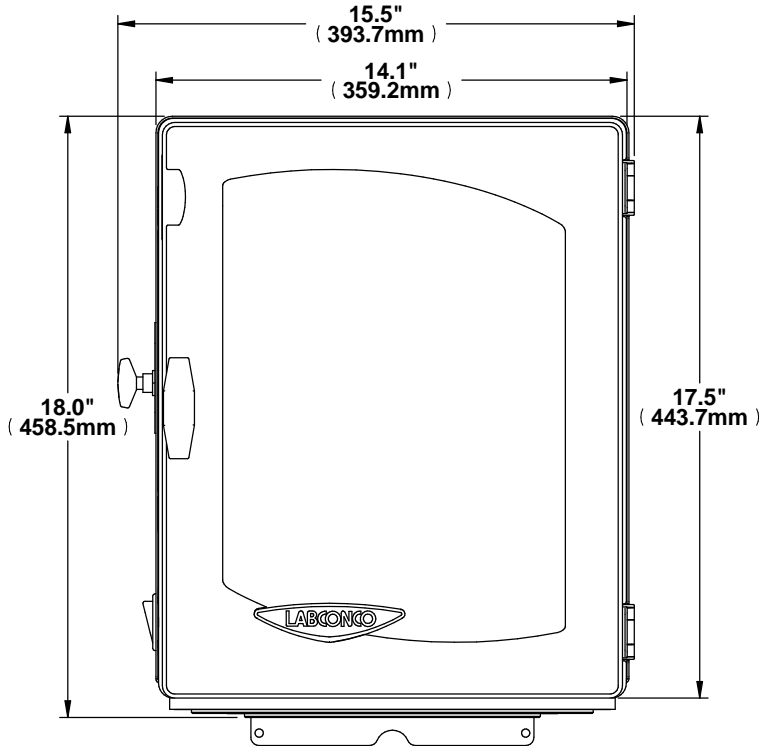
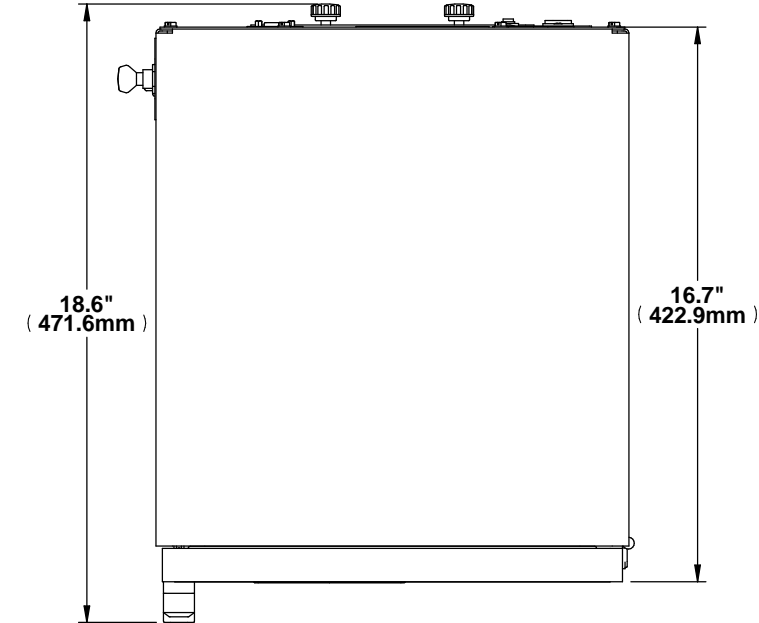



## Electrical Specifications

Catalog #	Description	Voltage		Frequency	Current Rating
		Nominal	Operating Range	(Hz)	Amps
780701000	Small Tray Dryer	115V	103 - 127	50/60	5.0
780701010 780701015 780701030 780701040 780701050 780701070	Small Tray Dryer	230V	207 - 253	50/60	2.5

## Environmental Conditions

- Indoor use only.
- Ambient temperature range: 41° to 104°F (5° to 40°C).
- Maximum relative humidity: 80% for temperatures up to 88°F (31°C), decreasing linearly to 50% relative humidity at 104°F (40°C).
- Main supply voltage fluctuations not to exceed  $\pm 10\%$  of the nominal voltage.
- Transient over voltages according to Installation Categories II (Over voltage Categories per IEC 1010). Temporary voltage spikes on the AC input line that may be as high as 1500V for 115V models and 2500V for 230V models are allowed.
- Used in an environment of Pollution degrees 2 (i.e., where normally only non-conductive atmospheres are present). Occasionally, however, a temporary conductivity caused by condensation must be expected, in accordance with IEC 664.