

LAB

LIQUIPORT

DIAPHRAGM
LABORATORY PUMP

NF 100...18
NF 1.100...18
NF 300...18
NF 1.300...18
OPERATING INSTRUCTIONS



KNF Flodos AG
Wassermatte 2
6210 Sursee, Switzerland
Tel +41 (0)41 925 00 25
Fax +41 (0)41 925 00 35
www.knf.com

| | |
|---|-----------|
| 1. General information | 5 |
| 1.1 Information about the instructions | 5 |
| 1.2 Warnings | 6 |
| 1.3 Symbols | 7 |
| 1.4 Disclaimer of liability | 8 |
| 1.5 Manufacturer's address | 8 |
| 1.6 Year of manufacture | 8 |
| 1.7 Other applicable documents | 8 |
| 1.8 Copyright | 8 |
| 1.9 Warranty conditions | 8 |
| 2. Safety | 9 |
| 2.1 Intended use | 9 |
| 2.2 Reasonably foreseeable misuse | 9 |
| 2.3 Owner's responsibility | 10 |
| 2.4 Personnel requirements | 10 |
| 2.5 Product-specific dangers | 11 |
| 2.6 Personal protective equipment | 12 |
| 2.7 Safety equipment | 12 |
| 2.8 Environmental protection considerations | 13 |
| 2.9 Danger areas | 13 |
| 2.10 Declaration of conformity | 14 |
| 3. Technical data | 15 |
| 3.1 Items included in delivery | 15 |
| 3.2 Storage conditions | 15 |
| 3.3 Pump materials | 15 |
| 3.4 Product key | 16 |
| 3.5 Dimensions | 17 |
| 3.6 Installation location requirements | 18 |
| 3.7 Electrical connections and performance data | 18 |
| 3.8 Other parameters | 19 |
| 3.9 External actuation (RC version only) | 20 |
| 3.10 Hydraulic ratings | 21 |
| 3.11 Hydraulic connections | 22 |
| 3.12 Transferred medium | 23 |
| 4. Assembly and function | 24 |
| 4.1 Metering pump assembly | 24 |
| 4.2 Operating principle | 24 |
| 5. Shipment | 25 |
| 5.1 Checking delivery | 25 |
| 5.2 Registering a complaint | 25 |
| 5.3 Arranging for return | 25 |
| 6. Installation and initial start-up | 26 |
| 6.1 Safety | 26 |
| 6.2 Installation | 27 |
| 6.3 Initial start-up | 30 |
| 7. Operation | 31 |
| 7.1 Safety | 31 |
| 7.2 Operating controls | 32 |
| 7.3 Starting the pump | 32 |
| 7.4 Stopping the transferring operation | 32 |
| 7.5 Adjusting the flow rate | 33 |
| 8. RC version – external actuation | 34 |
| 8.1 External actuation analog input | 34 |
| 8.2 Start/Stop pulse input | 35 |

| | | |
|------------|--|-----------|
| 8.3 | Digital output | 36 |
| 8.4 | Shutting down the pump in an emergency | 36 |
| 9. | Cleaning and maintenance | 37 |
| <hr/> | | |
| 9.1 | Safety | 37 |
| 9.2 | Maintenance plan | 37 |
| 9.3 | Cleaning the pump | 38 |
| 9.4 | Cleaning / replacing valve plates and pump diaphragm | 39 |
| 9.5 | Checking that pump is leak-tight | 42 |
| 10. | Shutdown | 43 |
| <hr/> | | |
| 10.1 | Safety | 43 |
| 10.2 | Procedure | 43 |
| 11. | Troubleshooting | 44 |
| <hr/> | | |
| 11.1 | Safety | 44 |
| 11.2 | Rectifying transfer problems | 45 |
| 12. | Spare parts and accessories | 46 |
| <hr/> | | |
| 12.1 | Spare parts | 46 |
| 12.2 | Accessories | 46 |
| 13. | Decontamination declaration | 47 |
| <hr/> | | |

1. General information

1.1 Information about the instructions

| | |
|-----------------------------------|---|
| Contents | The Operating Instructions contain important notes on how to use the pump. In order to ensure safe working and proper functioning it is essential to observe all the specified safety precautions. |
| Storage location | These Operating Instructions are part of the product, and must be stored in its immediate vicinity in a location accessible to personnel at all times. |
| Passing on | These Operating Instructions are part of the product, and must be passed on to the next owner if the device is resold. |
| Project pumps | Customer-specific project pumps (pump models which begin with "PL" or "PML") may differ from the Operating Instructions, in which case the agreed specification is also applicable. It is listed with the other applicable documents. |
| Illustrations in the instructions | Illustrations in these Operating Instructions may be to scale, but do not have to be. The illustrations may differ slightly from the actual product. |

1.2 Warnings

Warnings in the Operating Instructions are identified with the danger symbol, keywords and colours. These provide an indication of the extent of the danger.



DANGER

Indicates a dangerous situation which will lead directly to death or serious injury if it is not avoided.



WARNING

Indicates a dangerous situation which may lead to death or serious injury if it is not avoided.



CAUTION

Indicates a dangerous situation which may lead to moderate or minor injuries if it is not avoided.

NOTE

Indicates a situation which may cause damage to property if it is not avoided.

1.3 Symbols

The following symbols appear in the Operating Instructions, on labels on the device, and on its packaging:



| |
|---|
| ⚠ WARNING |
| <p>Danger of injuries and property damage caused by illegible labels</p> <p>The labelling on the device may become illegible with time.</p> <ul style="list-style-type: none"> - Maintain labels on the device in a legible condition. - Replace any illegible labels. |

The following symbols in the Operating Instructions and on the device and its packaging indicate environmental protection considerations:



Recycling



Not to be disposed of with household waste

The following symbols in safety precautions and on the device indicate the nature of the danger:



General danger symbol

Further details of the nature of the danger are provided in the warning highlighted by this symbol.



Electrical danger



Fire danger



Danger of caustic burns or burns



Danger of automatic start-up



Disconnect device from power supply by pulling out the mains plug

1.4 Disclaimer of liability

In preparing the contents of these Operating Instructions, account has been taken of applicable regulations and the state of the art.

The manufacturer can accept no liability for any damage or malfunctions caused by failure to follow the Operating Instructions.

The manufacturer can accept no liability for any damage or malfunctions caused by modification or conversion of the device or improper handling.

The manufacturer can accept no liability for any damage or malfunctions caused by the use of non-approved spare parts and accessories.

1.5 Manufacturer's address

KNF Flodos AG
Wassermatte 2
6210 Sursee, Switzerland
Tel +41 (0)41 925 00 25
Fax +41 (0)41 925 00 35
www.knf.com

1.6 Year of manufacture

The year of manufacture is shown on the device's type plate.

1.7 Other applicable documents

The documents listed must also be taken into consideration.

- Chemical resistance list
- Sales documents
- GTCs

1.8 Copyright

The information, texts and illustrations in these Operating Instructions are protected by copyright. The contents of these Operating Instructions must not be copied, translated or passed to third parties without the written consent of the manufacturer.

1.9 Warranty conditions

The applicable warranty conditions are set out in the General Terms and Conditions of Business and the sales documents.

The warranty does not cover the following:

- Malfunctions caused by particles/fibres in the valve system
- Sticking of the valve system as a result of inadequate flushing

2. Safety

2.1 Intended use

This pump is intended exclusively for use as follows:

- For transferring and metering liquids.
- For indoor operation.
- For temporary operation in laboratories for research purposes.
- For operation in accordance with the operating parameters specified in the technical data (see Chapter 3) and other applicable documents.
- For transferring media which meet the requirements in the technical data and other applicable documents.
- For operation in fully assembled condition.
- For upright operation on a firm table top.

2.2 Reasonably foreseeable misuse

The pump may not:

- be operated in an explosive atmosphere;
- be used to transfer explosive media;
- be used to produce foodstuffs or pharmacological products (additional certifications are required for this purpose);
- be used to transfer media whose compatibility with the pump head, valves, diaphragm and seals has not been established;

2.3 Owner's responsibility

The operator is responsible for compliance with the safety precautions in these Operating Instructions and with any safety, accident prevention and environmental protection regulations which apply to the medium to be transferred and the range of applications of the device.

These include the following in particular:

- The operator must perform a risk assessment to identify any additional risks which may arise from the specific working conditions at the pump's installation location and the nature of the medium to be transferred. The operator must convert these into instructions for operating the device.
- The operator must ensure that any employees working with the pump have read the Operating Instructions.
- The operator must train personnel at regular intervals and inform them of the risks involved.
- The operator must provide personnel with the necessary protective equipment as specified in the safety data sheet for the medium to be transferred.
- The operator must maintain the pump in perfect working order.
- The operator must ensure compliance with the maintenance intervals described in the Operating Instructions.

2.4 Personnel requirements



⚠ WARNING

Danger of injuries and property damage caused by insufficiently qualified staff

Improper use of the pump may result in serious injury and damage to property.

- All activities must be performed only by adequately qualified personnel.

The following qualifications are specified for various activities in the Operating Instructions:

| | |
|------------------------|--|
| Trained personnel | These have been instructed in the task assigned to them and made aware of potential dangers and risks. This training is the minimum qualification for working on the device. Where no other qualification is specified, the activity must be performed by a trained individual as a minimum. |
| Specialist personnel | The specialist training, knowledge and experience of such personnel, together with their knowledge of the relevant regulations, standards and directives, allow them to perform their assigned duties correctly, and to independently identify and avoid potential dangers and risks. |
| Unauthorised personnel | Individuals whose reactions have been impaired by the consumption of medicines, alcohol, drugs or by other causes and conditions are not authorised to perform activities on the device. |

2.5 Product-specific dangers

This chapter describes residual risks that have been identified in a risk assessment. Safety precautions and warnings in this chapter and in other chapters in the Operating Instructions must be observed in order to avoid dangerous situations.



DANGER

Danger of injuries and property damage caused by leaks in connections and the pump head

Poisoning and caustic burns, or undesirable reactions caused by escaping hazardous materials

- Maintain the torque of connections (see hydraulic connections)
- Check tightening torque of head screws regularly
- Only use pump if it is in perfect working order
- Operate pump in accordance with the technical data



DANGER

Danger of injuries and property damage caused by medium escaping from the discharge outlet

Poisoning and caustic burns, or undesirable reactions caused by escaping hazardous materials

- Place the pump in a suitable collecting vessel
- Never close the discharge outlet
- If medium escapes from the pump's discharge outlet, stop using the pump and contact your KNF dealer



DANGER

Risk of fire from escaping flammable media

Escaping or leaking flammable media can produce a combustible environment.

- Take fire protection precautions that are appropriate for the transferred media
- Keep ignition sources away
- Keep suitable extinguishers accessible
- Use means of fire detection



WARNING

Danger of serious injuries or property damage caused by escaping media in the event of overpressure on the suction side

Excessive pressure on the suction side will result in uncontrolled escape of fluid, even if the pump is not operating

- Avoid overpressure on the suction side

2.6 Personal protective equipment

Special protective equipment must be used when performing certain tasks. These are indicated separately in the individual chapters.

Where the wearing of protective equipment is concerned it is essential to observe the safety data sheet for the medium to be transferred.

The following symbols appear in the working area or in the Operating Instructions:



Safety gloves

to protect skin from contact with the transferred medium in accordance with the safety data sheet.



Safety glasses

to protect the eyes from contact with the transferred medium in accordance with the safety data sheet.



Face protection

to protect skin and eyes from contact with the transferred medium in accordance with the safety data sheet.

2.7 Safety equipment

2.7.1 Discharge outlet

⚠ DANGER

Danger of injuries and property damage caused by medium escaping from the discharge outlet

Poisoning and caustic burns, or undesirable reactions caused by escaping hazardous materials

- Place the pump in a suitable collecting vessel
- Check the discharge outlet regularly for leaks
- Never close the discharge outlet (see Fig. 1)
- If medium escapes from the pump's discharge outlet, stop using the pump and contact your KNF dealer

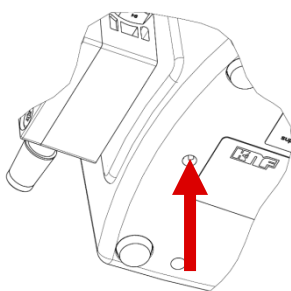

Fig. 1: Discharge outlet

If the pump diaphragm ruptures, the transferred medium is channelled out of the pump through the discharge outlet (see Fig. 1).

2.7.2 Emergency Stop

Pulling out the mains plug acts as an Emergency Stop. If the pump is installed permanently, an Emergency Stop and a maintenance switch must be fitted.



2.8 Environmental protection considerations

All replacement parts should be properly stored and disposed of in accordance with the applicable environmental protection regulations. Ensure adherence to the pertinent national and international regulations. This applies especially to parts contaminated with toxic substances.



Dispose of any packaging material that is no longer required in an environmentally friendly manner. The packaging materials are recyclable.

Dispose of end-of-life equipment in an environmentally friendly manner. Use appropriate waste collection systems for the disposal of end-of-life equipment. Used pumps contain valuable recyclable materials.

2.9 Danger areas

A discharge of aggressive, corrosive, ionizing, flammable or biological liquids can be dangerous.

The pump danger area should be limited by safe workplaces. Safe workplaces should comply with the requirements of local work safety regulations.

2.10 Declaration of conformity



EU-KONFORMITÄTSERKLÄRUNG

EC DECLARATION OF CONFORMITY

Hiermit erklärt der Hersteller

Hereby declares the manufacturer

KNF Flodos AG, Wassermatte 2, CH-6210 Sursee, Schweiz

for the product identified below

Für das nachfolgend bezeichnete Produkt

| BEZEICHNUNG DENOMINATION | FUNKTION FUNCTION | MODELL MODEL | TYP TYPE |
|-----------------------------|----------------------|-----------------|--------------|
| Labor Membranpumpe | Pumpe | NF 100 | .18S / .18RC |
| Labor Membranpumpe | Pumpe | NF 1.100 | .18S / .18RC |
| Labor Membranpumpe | Pumpe | NF 300 | .18S / .18RC |
| Labor Membranpumpe | Pumpe | NF 1.300 | .18S / .18RC |

(Seriennummer siehe Typenschild)

(Serial number see type label)

dass die grundlegenden Anforderungen erfüllt werden, die in den nachfolgenden Harmonisierungsvorschriften festgelegt sind.

that it meets the essential requirements which are laid down in the following harmonization of the laws.

| | |
|--|--|
| RICHTLINIE 2011/65/EU DES EUROPÄISCHEN PARLAMENTS UND DES RATES vom 8. Juni 2011 zur Beschränkung der Verwendung bestimmter gefährlicher Stoffe in Elektro- und Elektronikgeräten | DIRECTIVE 2011/65/EU OF THE EUROPEAN PARLIAMENT AND OF THE COUNCIL of 8 June 2011 on the restriction of the use of certain hazardous substances in electrical and electronic equipment |
| RICHTLINIE 2006/42/EG DES EUROPÄISCHEN PARLAMENTS UND DES RATES vom 17. Mai 2006 über Maschinen und zur Änderung der Richtlinie 95/16/EG | DIRECTIVE 2006/42/EC OF THE EUROPEAN PARLIAMENT AND OF THE COUNCIL of 17 May 2006 on machinery, and amending Directive 95/16/EC |
| RICHTLINIE 2014/30/EU DES EUROPÄISCHEN PARLAMENTS UND DES RATES vom 26. Februar 2014 zur Harmonisierung der Rechtsvorschriften der Mitgliedstaaten über die elektromagnetische Verträglichkeit | DIRECTIVE 2014/30/EU OF THE EUROPEAN PARLIAMENT AND OF THE COUNCIL of 26 February 2014 on the harmonisation of the laws of the Member States relating to electromagnetic compatibility |
| RICHTLINIE 2009/125/EG DES EUROPÄISCHEN PARLAMENTS UND DES RATES vom 21. Oktober 2009 zur Schaffung eines Rahmens für die Festlegung von Anforderungen an die umweltgerechte Gestaltung energieverbrauchsrelevanter Produkte | DIRECTIVE 2009/125/EC OF THE EUROPEAN PARLIAMENT AND OF THE COUNCIL of 21 October 2009 establishing a framework for the setting of ecodesign requirements for energy-related products |

Folgende harmonisierte Normen wurden angewandt:

The following harmonized standards have been used:

| FUNDSTELLE REFERENCE | AUSGABEDATUM RELEASE DATE | TITEL TITLE |
|---|------------------------------|---|
| Harmonisierte Normen für die RoHS-Richtlinie | | |
| EN 50581 | 2012 | Technische Dokumentation zur Beurteilung von Elektro- und Elektronikgeräten hinsichtlich der Beschränkung gefährlicher Stoffe |
| Harmonisierte Normen für die Maschinenrichtlinie: | | |
| EN ISO 12100 | 2010 | Sicherheit von Maschinen - Allgemeine Gestaltungsleitsätze - Risikobeurteilung und Risikominderung |
| Harmonisierte Normen für die EMV-Richtlinie | | |
| EN 61326-1 | 2013 | Elektrische Mess-, Steuer-, Regel- und Laborgeräte - EMV-Anforderungen - Teil 1: Allgemeine Anforderungen |
| Harmonisierte Normen für die Niederspannungsrichtlinie | | |
| EN 61010-1 | 2010 | Sicherheitsbestimmungen für elektrische Mess-, Steuer-, Regel- und Laborgeräte - Teil 1: Allgemeine Anforderungen |

Bevollmächtigte Person für die Zusammenstellung der technischen Unterlagen:

Authorised person to compile the relevant technical documentation:

Daniel Kohli, Product Development, KNF Flodos AG, Wassermatte 2, CH-6210 Sursee, Schweiz

Sursee, 13.06.2018

Ort, Datum (TT.MM.JJJJ)
Place, date, (dd.mm.yyyy)

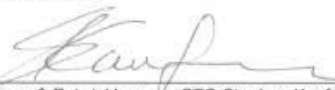

Leiter Forschung & Entwicklung CTO Stephan Kaufmann
Chief Technology Officer

3. Technical data

3.1 Items included in delivery

- LIQUIPORT pump
- Mains plug
- Operating instructions

3.2 Storage conditions

- Pumps must be stored in a dry place and protected from contamination.
- The storage temperature must be between 5°C and 40°C.
- The pump is supplied with protective caps. These protective caps must be fitted during storage.
- Store pump upright and with protection.

3.3 Pump materials

The type designation **KT** stands for:

| Assembly | Material ¹⁾ |
|---------------------|------------------------|
| Pump head | PP |
| Valve plate / seals | FFKM |
| Diaphragm | PTFE-coated |
| Housing | PA, TPE, PC |

Tab. 1: KT

¹⁾ according to DIN ISO 1629 and 1043.1

The type designation **TT** stands for:

| Assembly | Material ¹⁾ |
|---------------------|------------------------|
| Pump head | PVDF |
| Valve plate / seals | FFKM |
| Diaphragm | PTFE-coated |
| Housing | PA, TPE, PC |

Tab. 2: TT

¹⁾ according to DIN ISO 1629 and 1043.1

The type designation **FT** stands for:

| Assembly | Material ¹⁾ |
|---------------------|------------------------|
| Pump head | PTFE |
| Valve plate / seals | FFKM |
| Diaphragm | PTFE-coated |
| Housing | PA, TPE, PC |

Tab. 3: FT

¹⁾ according to DIN ISO 1629 and 1043.1

3.4 Product key

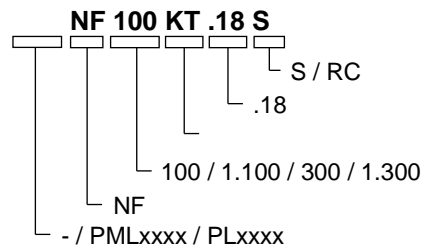

| Description | Meaning |
|---------------------------|---|
| PML / PL | Customer-specific designs |
| NF | Flodos liquid pump |
| 100 / 1.100 / 300 / 1.300 | Pump type |
| KT / TT / FT | Head material |
| .18 | Laboratory device with housing |
| S / RC | S without external actuation RC with external actuation (remote control) |

Tab. 4: Product key

3.5 Dimensions

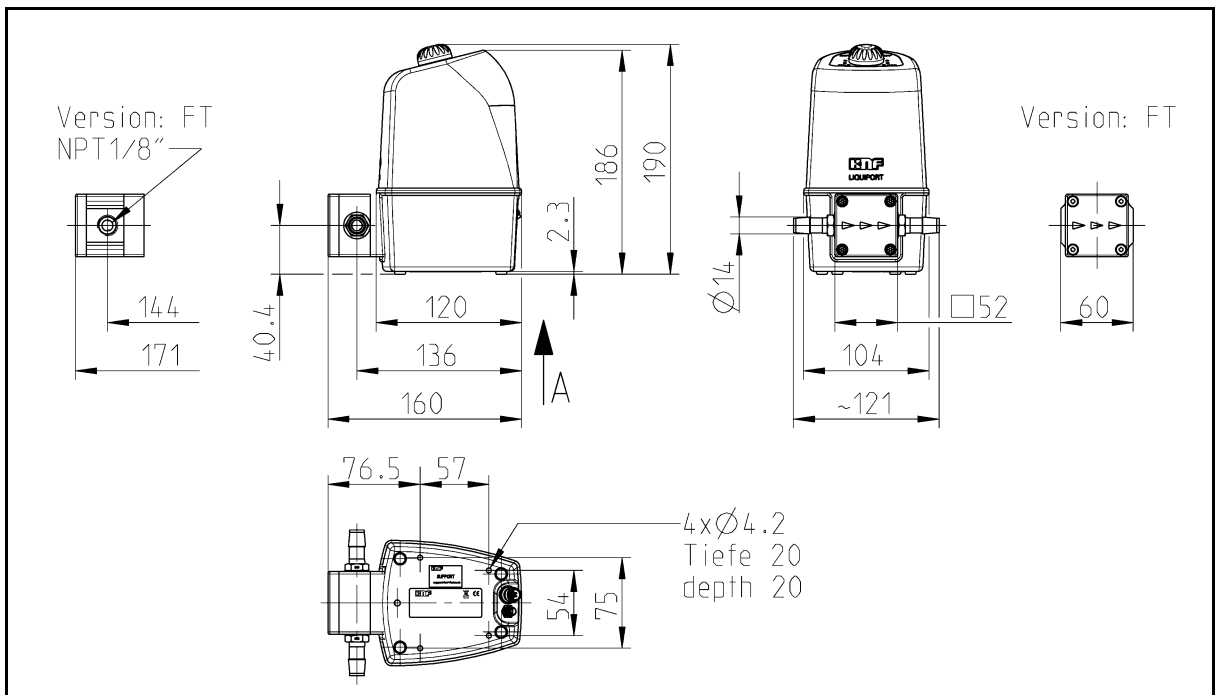
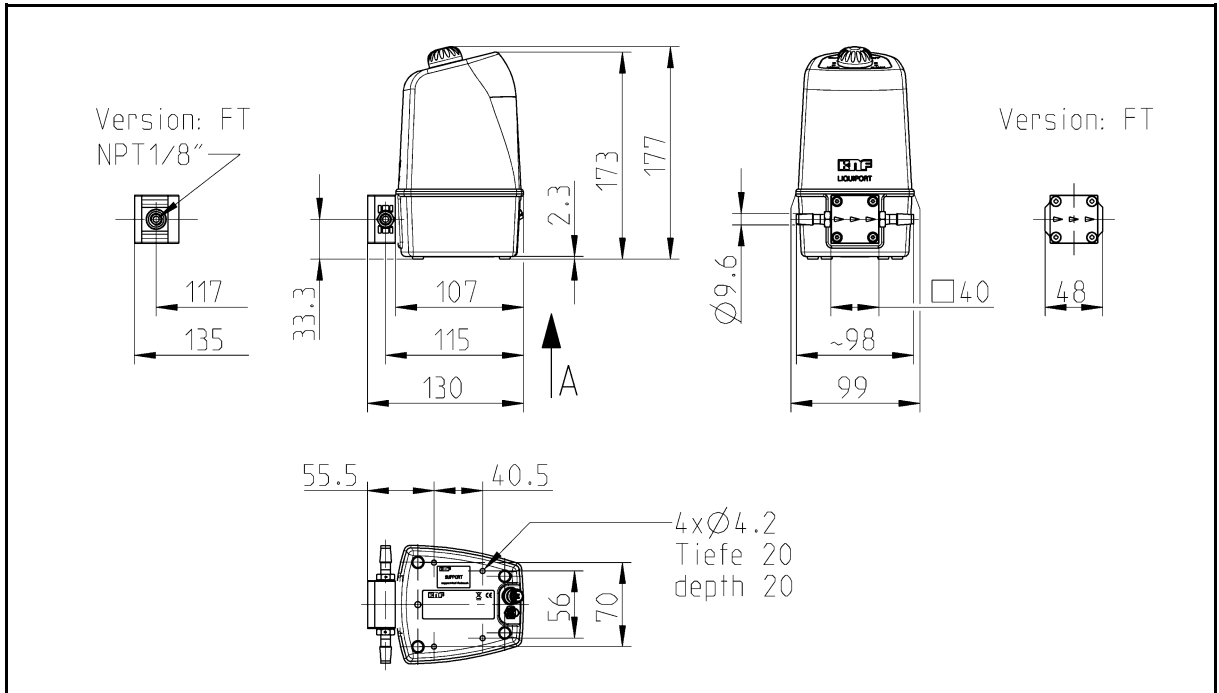

3.6 Installation location requirements

The pump is designed to be operated in an upright position.

| NOTE |
|---|
| <p>An unsuitable location may cause damage to the device</p> <ul style="list-style-type: none"> - Install in a dry place - Protect the installation location of the pump from water in the form of rain, spray, splashes and drips - Do not operate the pump in an aggressive or flammable environment - Choose a safe location (a level, flat surface) for the pump - Place the pump in a suitable collecting pan - If the stability of the pump cannot be ensured, fasten the pump in place using two screws - Make sure that the hose connections can be fitted without strain on the hoses - Protect the pump against shocks, impacts and strong vibrations |

3.7 Electrical connections and performance data

| Pump type | LIQUIPORT 100 | LIQUIPORT 1.100 |
|---|--------------------------------|-----------------|
| Nominal mains voltage [V] | 100 – 240V AC +/- 10%, | |
| Frequency [Hz] | 50-60 Hz | |
| Max. power consumption AC 100 V / 115 V / 240 V [W] | 12 / 12 / 12 | 15 / 15 / 16 |
| Max. power consumption DC [W] | 12 | 16 |
| Pump DC voltage [V] | 24V DC | |
| Maximum operating current, DC RMS 24 V [A] | 0.5 | 0.65 |
| Max. short-term peak current [A] | 0.8 | 0.9 |
| Power supply fuse | Electronic overload protection | |
| Pump fuse | Electronic overload protection | |

Tab. 5: Electrical data LIQUIPORT 100

| Pump type | LIQUIPORT 300 | LIQUIPORT 1.300 |
|---|--------------------------------|-----------------|
| Nominal mains voltage [V] | 100 – 240V AC +/- 10%, | |
| Frequency [Hz] | 50-60 Hz | |
| Max. power consumption AC 100 V / 115 V / 240 V [W] | 25 / 25 / 25 | 30 / 30 / 30 |
| Max. power consumption DC [W] | 29 | 34 |
| Pump DC voltage [V] | 24V DC | |
| Maximum operating current, DC RMS 24 V [A] | 1.2 | 1.4 |
| Max. short-term peak current [A] | 1.4 | 1.65 |
| Power supply fuse | Electronic overload protection | |
| Pump fuse | Electronic overload protection | |

Tab. 6: Electrical data LIQUIPORT 300

3.8 Other parameters

| Pump type | LIQUIPORT 100 LIQUIPORT 1.100 | LIQUIPORT 300 LIQUIPORT1.300 |
|--|----------------------------------|---------------------------------|
| Pump weight [kg] 1) | 0.8 | 1.5 |
| Permissible ambient temperature [°C] | +5 to +40 | |
| Permissible media temperature [°C] | +5 to +80 | |
| Permissible working height [m above sea level] | 2000 | |
| Max. humidity | 90% (non-condensing) | |
| Nominal speed [rpm] | 3000 rpm | |
| Noise level [dBA] | < 40dBA | |
| Pump protection type | IP 65 | |
| Power supply protection type | IP 40 | |
| Protection class | III | |

Tab. 7: Other parameters

¹⁾ The weight may differ slightly from the stated value, depending on the version.

3.9 External actuation (RC version only)

| Parameter | Value |
|---|-------------------------------------|
| Analog input | |
| Signal range | 0-10V |
| Signal range optional 1) | 0-20mA |
| Input resistance | 133 kΩ at 0-10 V 510 Ω at 0-20mA |
| Dielectric strength | 24V DC |
| Digital input | |
| Signal range | Pull up to 24 V |
| Dielectric strength | 24V DC |
| Voltage level without external wiring | 19V typ. |
| Level low | ≤ 4.0V = low |
| Level high | ≥ 14.0V = high |
| Pull-up resistance | 10 kΩ |
| Resistance to ground/GND | 43 kΩ |
| Digital output – open-collector output (NPN transistor to GND) | |
| Dielectric strength | 24V DC |
| Loading capacity/output current low level | 0...10mA typ. 20mA max. |

Tab. 8: External actuation

¹⁾ Optional on request.

- 1 Analog input
Brown
- 2 External actuation jumper
White
- 3 Pulse input
Blue
- 4 Open collector output
Black
- 5 Ground
Grey

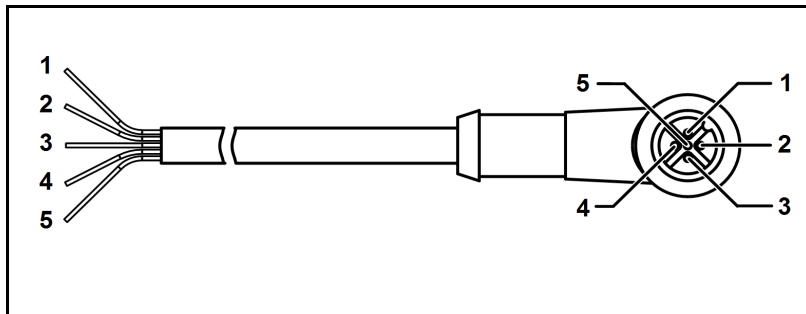

Fig. 4: RC cable pin assignment

| Pin no. | Lead colour | Description | Function |
|---------|-------------|---------------------------|--|
| 1 | brown | Analog input | (0%) 15% to 100% flow rate |
| 2 | white | External actuation jumper | Switches pump over to external actuation. → Control knob is deactivated |
| 3 | blue | Pulse input | Start/Stop via external actuation |
| 4 | black | Open collector output | Operating mode output (On/Off) |
| 5 | grey | Ground/GND | -- |

Tab. 9: RC cable pin assignment

3.10 Hydraulic ratings

| Type | LIQUIPORT 100 | LIQUIPORT 1.100 |
|---|---------------|-----------------|
| Flow rate [l/min] ^{1) 2)} | 0.2 - 1.3 | 0.2 - 1.3 |
| Suction head [mWG] | 3 | 3 |
| Max. inlet pressure [bar g] ³⁾ | 0.4 | 0.4 |
| Permissible pressure [bar g] | 1.0 | 4.0 |
| Permissible medium viscosity [cSt] | 150 | 150 |

Tab. 10: Hydraulic ratings LIQUIPORT 100 / LIQUIPORT 1.100

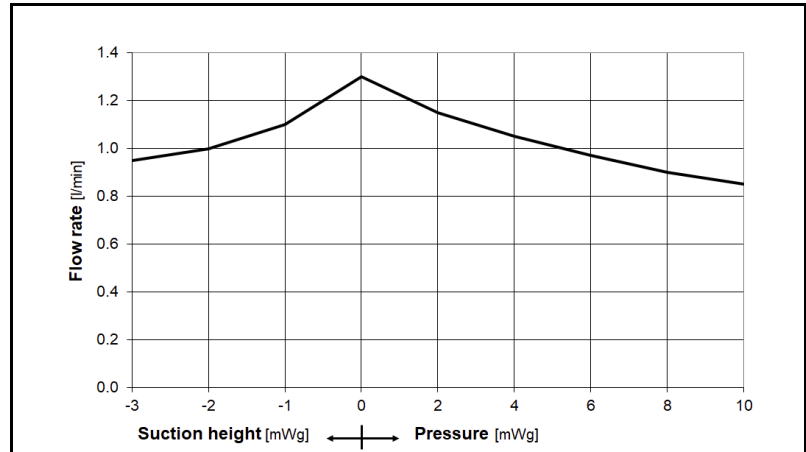

Fig. 5: Flow rate curve LIQUIPORT 100

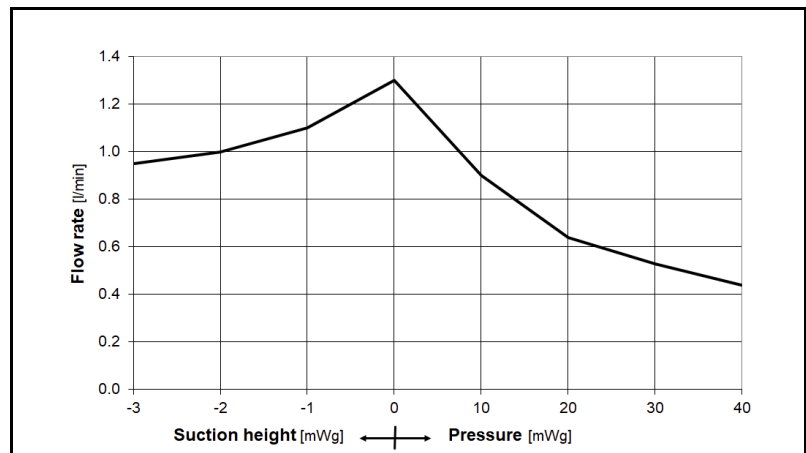

Fig. 6: Flow rate curve LIQUIPORT 1.100

¹⁾ Measured with water at 20°C

²⁾ Flow rates may vary from the values shown, depending on fluid viscosity, pump head material and the hoses / hose connectors used.

³⁾ Overpressure on the suction side will result in uncontrolled escape of fluid, even if the pump is not operating. The pressure increase via the pump must be positive.

| Pump type | LIQUIPORT 300 | LIQUIPORT 1.300 |
|---|---------------|-----------------|
| Flow rate [l/min] ^{1) 2)} | 0.5 - 3.0 | 0.5 - 3.0 |
| Suction head [mWG] | 3 | 3 |
| Max. inlet pressure [bar g] ³⁾ | 0.4 | 0.4 |
| Permissible pressure [bar g] | 1.0 | 4.0 |
| Permissible medium viscosity [cSt] | 150 | 150 |

Tab. 11: Hydraulic ratings

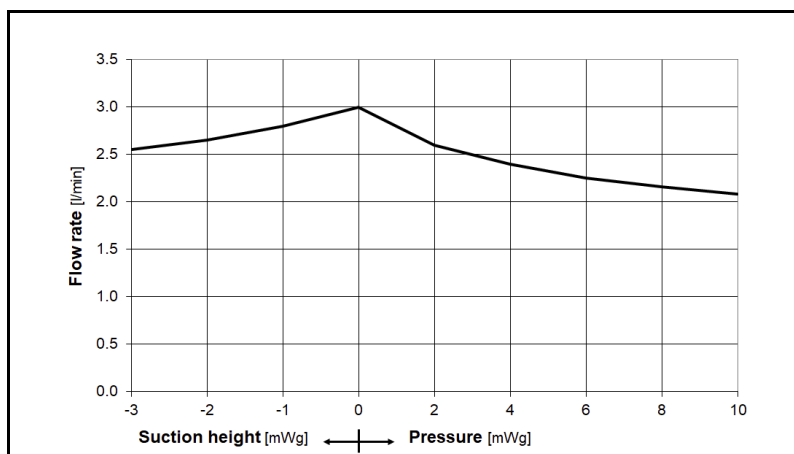

Fig. 7: Flow rate curve LIQUIPORT 300

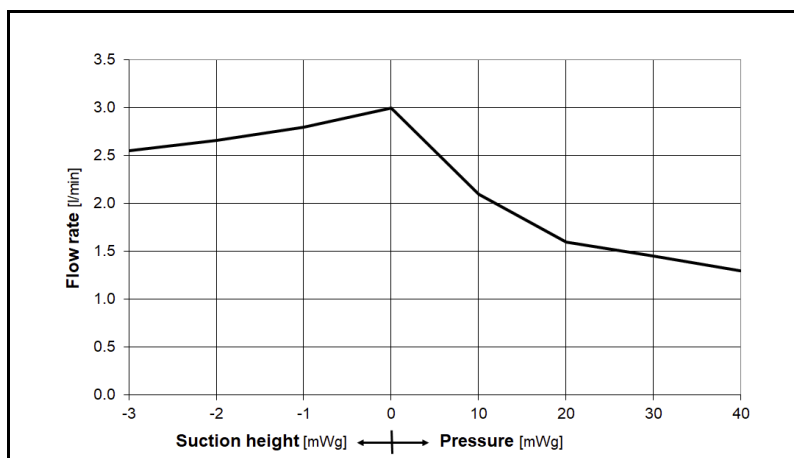

Fig. 8: Flow rate curve LIQUIPORT 1.300

- 1) Measured with water at 20°C
- 2) Flow rates may vary from the values shown, depending on fluid viscosity, pump head material and the hoses / hose connectors used.
- 3) Overpressure on the suction side will result in uncontrolled escape of fluid, even if the pump is not operating. The pressure increase via the pump must be positive.

3.11 Hydraulic connections

| Pump type | Connection |
|----------------------------------|---|
| LIQUIPORT 100 LIQUIPORT 1.100 | Internal thread NPT 1/8" with hose connector for hose ID 8mm |
| LIQUIPORT 300 LIQUIPORT 1.300 | Internal thread NPT 3/8" with hose connector for hose ID 12mm |

Tab. 12: Hydraulic connections

3.12 Transferred medium

| Parameter | Value |
|---|-----------|
| Permissible medium viscosity [cSt] | 150 |
| Ideally free of solids, max. particle size [μm] | < 70 |
| Permissible media temperature ¹ [$^{\circ}\text{C}$] | +5 to +80 |

WARNING

Poisoning and caustic burns

If corrosive, poisonous, ionising or biological media come into contact with skin, eyes and the respiratory tract they may cause serious injuries

- Observe the safety data sheets for the media to be transferred
- Use personal protective equipment
- Operate the pump in a suitably protected area
- Check the resistance of any parts which come into contact with the fluid (see chemical resistance list or consult your local KNF dealer)



WARNING

Damage caused by ionising radiation

Radioactive materials cause serious damage to health and reduce the service life of the pump.

- Decontaminate the pump
- Wear personal protective equipment
- Mark the pump



NOTE

If the absence of solid material in the pumped material is not ensured, a filter < 70 μm with a sufficiently large filtration surface area must be installed upstream of the pump in order to prevent damage to the pump.

NOTE

Before using a medium, check the compatibility of the materials of the pump head, pump housing, diaphragm and valves with the medium.

- Check the resistance, see the resistance list
- Clarify resistance with KNF

¹ Applies to water and low-reactivity media. For aggressive media, resistance is to be checked at a higher medium temperature.

4. Assembly and function

4.1 Metering pump assembly

- 1 On/Off button
- 2 Control knob
- 3 Flow rate indicator
- 4 Standby indicator
- 5 External indicator
- 6 Inlet
- 7 Pump head
- 8 Outlet
- 9 Power supply plug
- 10 External actuation plug (RC version only)

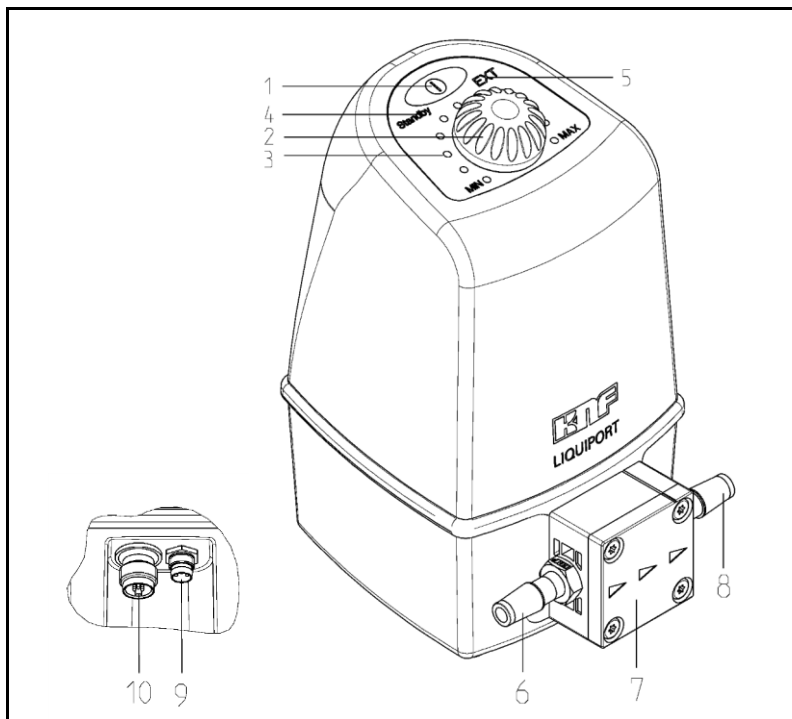

Fig. 9: Diaphragm pump

4.2 Operating principle

- 1 Outlet valve
- 2 Inlet valve
- 3 Working chamber
- 4 Diaphragm
- 5 Eccentric
- 6 Connecting rod
- 7 Pump drive

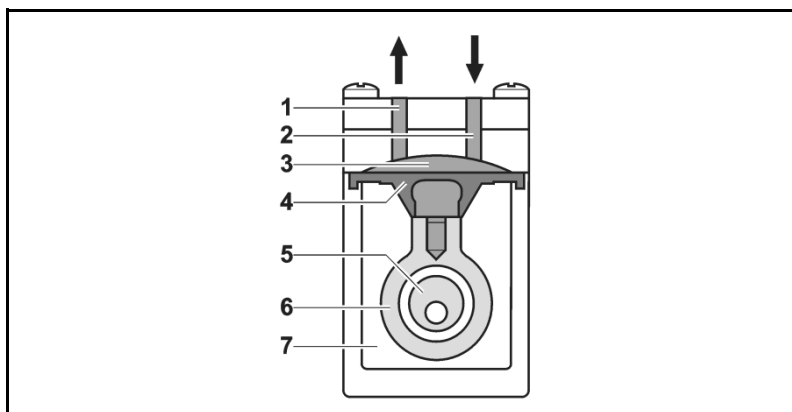

Fig. 10: Pump assembly

The diaphragm liquid pumps are based on reciprocating displacement pump technology. The elastic diaphragm (4) is moved up and down by the eccentric (5) and the connecting rod (6). In the downward stroke it aspirates the medium to be transferred via the inlet valve (2). In the upward stroke the diaphragm pushes the medium out of the pump head via the outlet valve (1). The diaphragm hermetically seals off the working chamber (3) from the pump drive (7).

5. Shipment

5.1 Checking delivery

Requirements

- Device delivered and packaged

Procedure

1. Check delivery for visible damage
2. Check that delivery is correct and complete using the packing list
3. In the event of a discrepancy, register a complaint.
4. Keep original packaging in case you have to return the item

5.2 Registering a complaint

Requirements

- Device damaged or incomplete

Procedure

1. If there are any visible signs of damage, only accept the delivery with reservations.
2. Damage and complaints of any kind should be recorded on the delivery note
3. Notify the manufacturer of any damage and complaints

5.3 Arranging for return

Requirements

- Device damaged or incomplete

Procedure

1. Contact KNF before returning the device
2. Flush and decontaminate pump
3. Fill out decontamination declaration and attach to the pump
4. Send the pump in its original packaging to a service location or one of our product centres
5. The pump can be sent by parcel service or post in its original packaging



! DANGER

Danger of poisoning, chemical burns, or radioactive contamination through contact with pump parts that are not decontaminated

Contact with pump parts that are not properly decontaminated will result in poisoning, chemical burns, or radioactive contamination.

- Use personal protective equipment
- Flush and decontaminate the pump until the possibility of danger can be eliminated.
- Label any pumps that are used with particularly dangerous media
- Only decontaminated pumps may be sent

NOTE

KNF retains the right to refuse repair of pumps that are used to move hazardous materials.

This applies particularly to the following materials:

- Poisons
- Radioactive media
- Elementary halogens (e.g. bromine)

6. Installation and initial start-up

6.1 Safety



⚠ WARNING

Danger as a result of incorrect installation

Injuries or damage to equipment caused by escaping media

- Follow installation instructions
- After assembly, test the system with a harmless liquid
- Only use pump if it is in perfect working order



⚠ WARNING

Danger of serious injuries or property damage caused by escaping media in the event of rupturing of the pump diaphragm

Poisoning and caustic burns caused by escaping media as a result of rupturing of the pump diaphragm. If the pump diaphragm ruptures, the medium is channelled out of the pump through the discharge outlet.

- When transferring critical media, operate the pump in a collecting tank
- Check discharge outlet for leaks



⚠ WARNING

Danger of serious injuries or property damage caused by escaping media in the event of overpressure on the suction side

Overpressure on the suction side will result in uncontrolled escape of fluid, even if the pump is not operating.

- Avoid overpressure on the suction side

The following requirements apply to all the activities described in this chapter:

| | |
|-------------------------------|---|
| Requirements | <ul style="list-style-type: none"> ▪ Device is in perfect working order ▪ The system is operated with water |
| Personnel | <ul style="list-style-type: none"> ▪ Must be assembled by specialist personnel |
| Personal protective equipment | <ul style="list-style-type: none"> ▪ Not required |

6.2 Installation

Before installation, store the pump at the installation location to bring it up to ambient temperature.

NOTE

For problem-free, safe operation the following instructions should be followed:

- Install in a dry place.
- Protect the installation location of the pump from water in the form of rain, spray, splashes and drips.
- Do not operate the pump in an aggressive or flammable environment.
- Choose a safe location (a level, flat surface) for the pump.
- If the stability of the pump cannot be ensured, fasten the pump in place using two screws.
- Make sure that the hose connections can be fitted without strain on the hoses.
- Protect the pump against shocks, impacts and strong vibrations.

6.2.1 Connect mains plug

DANGER

Risk of electric shock

- Only operate the pump with the power supply unit supplied.
- Connect the cable from the mains plug to the pump's power supply socket.
- Plug the mains plug into a correctly installed and properly earthed mains socket.
- Ensure that the mains plug is protected from water splashes.
- Do not open pump housing or power supply unit.
- Disconnect pump from power supply during maintenance work.
- If pump is installed permanently, fit a maintenance switch.



When connecting the device to a power source, the relevant norms, directives, regulations and technical standards must be observed.

1. Use suitable adapters in the power supply unit
2. Connect power supply unit to pump

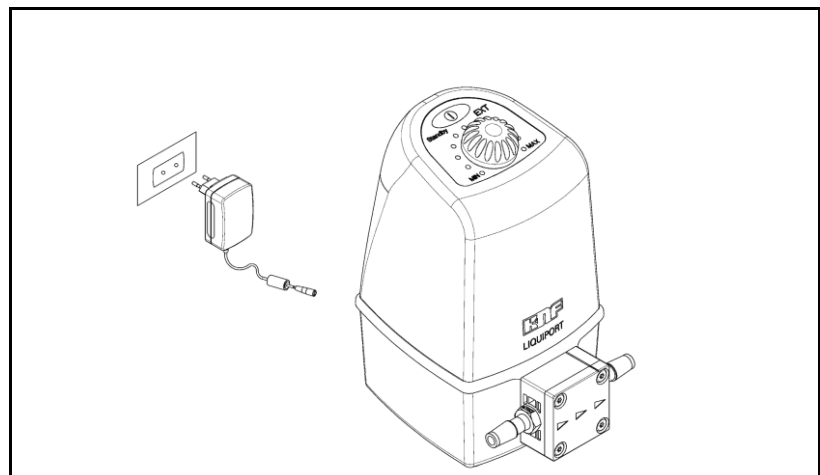

Fig. 11: Electrical connection

6.2.2 Connect hydraulics

- | | |
|-----------------------------------|--|
| Connected components | 1. Only connect components to the pump that are designed to handle the hydraulic data of the pump (see Chapter 3). |
| Hoses | 2. Only use hoses that are suitable for the maximum operating pressure of the pump (see Section 3). |
| Customer-specific pumps (PL, PML) | 3. Only use hoses that are sufficiently chemically resistant to the liquids being transferred. |
| | 4. The connections described below apply to standard products. Different connections may apply for customer-specific projects (PML or PL). |

NOTE

Arrows on the pump head indicate the flow direction.

Use of hose connectors

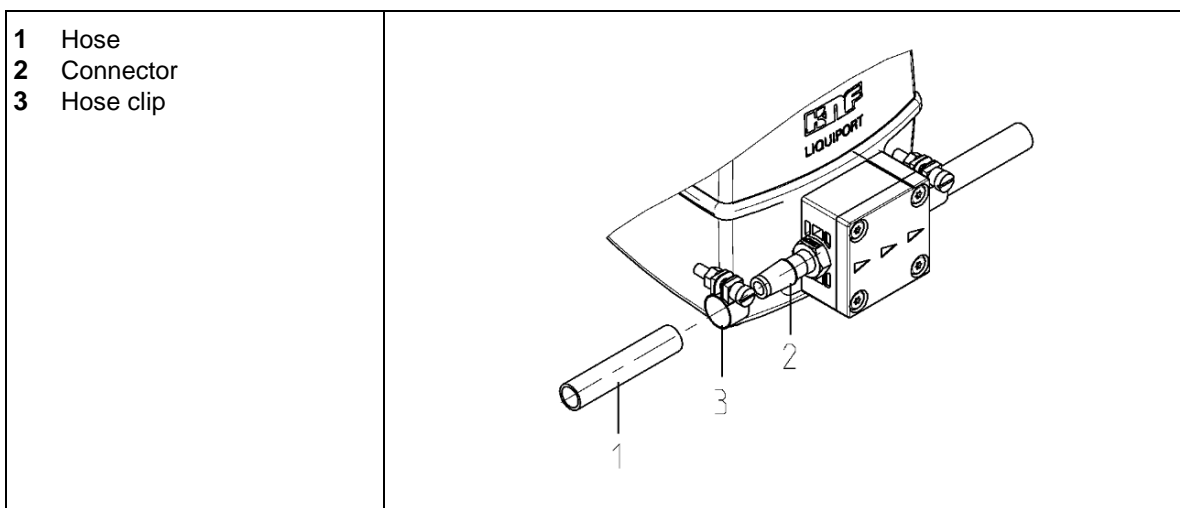

Fig. 12: Hose connector ID 8mm or ID 12mm

1. Remove protective caps from connections.
2. Suction and pressure lines (LIQUIPORT 100 and LIQUIPORT 1.100: hose ID 8mm; LIQUIPORT 300 and LIQUIPORT 1.300: hose ID 12mm), cut off straight with a sharp knife.
3. Push the hoses onto the connectors as far as they will go.
4. For pressure applications with LIQUIPORT 1.100 or LIQUIPORT 1.300, secure hoses with suitable hose clips.
5. Check that the hoses and transition joints (hose connector/hose) are fitted correctly and securely.
6. Check that the system is leak-tight.

Use of internal threads

- 1 Connector
- 2 Teflon sealing tape

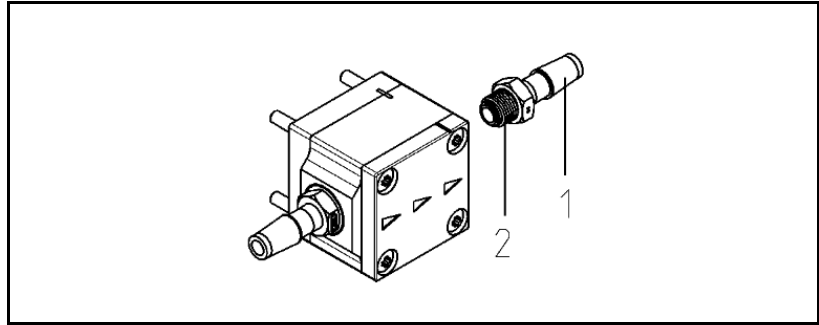

Fig. 13: Internal thread NPT 1/8"

| Pump type | Internal thread |
|----------------------------------|-----------------|
| LIQUIPORT 100 LIQUIPORT 1.100 | NPT 1/8" |
| LIQUIPORT 300 LIQUIPORT 1.300 | NPT 3/8" |

Tab. 13: Internal thread

1. Remove protective cap and screwed-in connectors from the connections.
2. Prepare required fitting with corresponding external thread with suitable sealant (e.g. Teflon sealing tape).
3. Screw in fitting and tighten.
4. Check that the fitting is fitted correctly and securely.
5. Check that the system is leak-tight.

6.3 Initial start-up



⚠ CAUTION

Danger of rupture of the fluid system as a consequence of over-pressure

The pump builds up pressure. In a closed system the max. permitted operating pressure may be exceeded, thus causing damage to the pump and/or the system

- In the case of parts that are in contact with the fluid, use only those that are designed for the pump's operating pressure as a minimum
- Do not transfer media against shut-off elements or closed systems, otherwise
- install pressure relief/safety valve and set to 6 bar (in the KNF product range)



⚠ CAUTION

Danger of unexpected chemical reactions with water

Water residues left in the pump from testing in the factory may react with the transferred medium.

- Before putting the pump into service, flush it with a non-critical medium

Before switching on the pump, check the following points:

Prerequisites for start-up

- All hoses attached properly
- Specifications of the power supply must correspond with the data on the pump and mains plug type plates.
- The pump outlet must be clear of any obstruction.
- All cables properly connected

Tab. 14: Prerequisites for start-up

1. Only operate the pump under the operating parameters and conditions described in Section 3.
2. Ensure that the pump is used as intended (see Section 2.1).
3. Avoid improper use of the pump (see Section 2.2).
4. Observe safety precautions.

6.3.1 Test the system

In order to prevent damage, the safety, leak-tightness and functioning of the test set-up should be checked using a suitable harmless medium, such as water.

7. Operation

7.1 Safety



⚠ DANGER

Danger of injuries and property damage caused by hazardous materials

Poisoning and caustic burns, or undesirable reactions caused by escaping hazardous materials

- Observe the safety data sheets for the media to be transferred
- Determine the resistance of the head materials
- Check tightening torque of head screws regularly (see Section 9.4)
- Check that pump and system are leak-tight
- Maintain the pump regularly
- Only use pump if it is in perfect working order
- Operate pump in accordance with the technical data



⚠ WARNING

Danger of undetected diaphragm rupture

The diaphragm may be damaged by aggressive media, and the medium may escape from the discharge outlet

- Operate the pump in a collecting pan
- Flush pump thoroughly after use or if it is not to be used for an extended period (see Chapter 9)
- Check the discharge outlet regularly for leaks
- Observe the service life of the diaphragm and other elastomer parts (see Maintenance)



⚠ WARNING

Danger of splashing media

If corrosive, poisonous, ionising or biological media come into contact with skin, eyes and the respiratory tract they may cause serious injuries

- Observe the safety data sheets for the media to be transferred
- Check that the system is leak-tight before use
- Use personal protective equipment

The following requirements apply to all the activities described in this chapter:

- Requirements
- Personnel
- Personal protective equipment



Special tools required

- Device is in perfect working order.
- The system has previously been operated and tested with a suitable harmless medium (e.g. water).
- Trained personnel
- The type of protective equipment required will depend on the medium to be transferred.
- Observe safety data sheets and regulations for the handling of the media to be transferred.
- At medium temperatures of over 50°C, take safety precautions against burns.
- When transferring very aggressive, biological, flammable or ionising media, a suitable work station with a safety and extraction system is to be used.

- 1 On/Off button
- 2 Control knob
- 3 Flow rate indicator
- 4 Standby indicator
- 5 External indicator

7.2 Operating controls

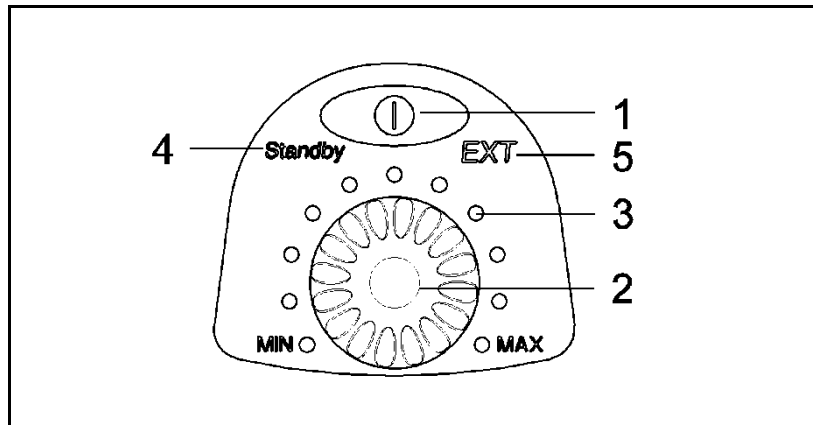

Fig. 14: Operating controls

7.3 Starting the pump

When it is connected to the power supply, the pump is in standby mode by default, and the "Standby" indicator illuminates.

➔ Briefly press the "On/Off" button and the pump will start to transfer.

The "Standby" indicator goes off.

i An externally actuated pump will start as soon as a valid control signal is present.

(see Chapter 8).

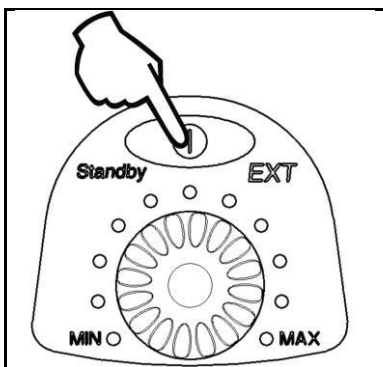

Fig. 15: Starting / stopping the pump

7.4 Stopping the transferring operation

➔ Briefly press the "On/Off" button and the pump will stop.

The "Standby" indicator goes on.

7.5 Adjusting the flow rate

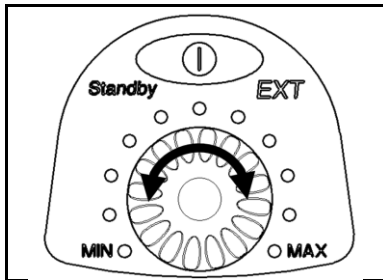

Fig. 16: Adjusting the flow rate

Set the pump to the required flow rate using the control knob.

The flow rate setting is shown by the flow rate indicator around the control knob.

| Type | Flow rate [l/min] |
|-----------------|-------------------|
| LIQUIPORT 100 | 0.2 to 1.3 |
| LIQUIPORT 1.100 | 0.2 to 1.3 |
| LIQUIPORT 300 | 0.5 to 3.0 |
| LIQUIPORT 1.300 | 0.5 to 3.0 |

Tab. 15: Specified flow

i If the analog input is active, the "EXT" indicator illuminates and the control knob has no function. The flow rate is then specified by the analog input. See Chapter 8.1

i The flow rate of the pump is reduced by counterpressure, suction head and higher medium viscosity.

i In the event of counterpressure, the pump will not start at low flow rate settings.

Reduce counterpressure or select a higher setting.

Operation in the event of counter-pressure

In the event of counterpressure the pump cannot be set to the lower flow rates. The counterpressure must be reduced or a higher flow rate must be selected.

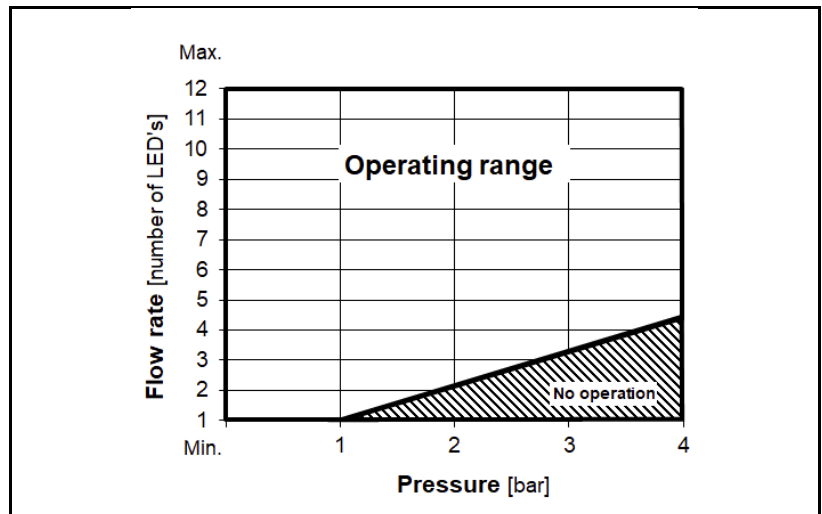

Fig. 17: Operating range

8. RC version – external actuation

⚠ WARNING

Danger of automatic start-up

The pump starts up by itself and without warning.

- Send the start command only when the system has been tested and is ready for operation
- Mark remote-controlled pumps
- Before start-up, check that hoses and equipment are leak-tight and working properly
- Do not operate the pump with hazardous media



i External actuation functions are available only in the RC version.

Connection details and technical data are provided in Chapter 3.9

8.1 External actuation analog input

The analog input can be used to externally control a pump flow rate from (0%) 15% to 100%.

Activating the analog input

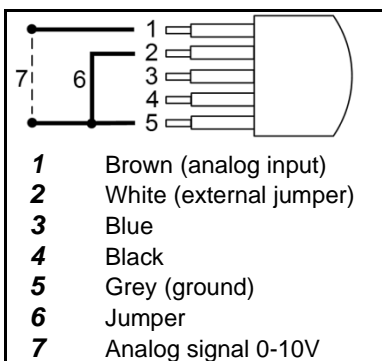

Fig. 18: RC cable jumper

The analog input must be activated by connecting the RC cable.

➔ With the RC cable connect the white lead (jumper) to the grey lead (ground) or with the RC connector, connect pin 2 to pin 5. See Fig. 18

➔ If external actuation is switched on, this is indicated on the pump by the illuminated "EXT" symbol. See Fig. 19

i When the analog input is active, the pump can be started only if a valid analog signal is present.

i The control knob is deactivated. Manual flow rate entry is blocked.

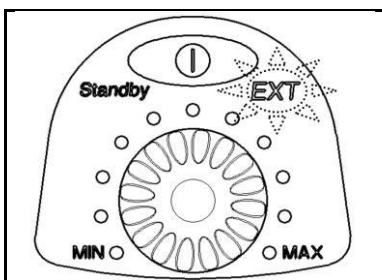

Fig. 19: "EXT" indicator

Control signals

| Name | |
|---------------|---------|
| Voltage range | 0 – 10V |
| On threshold | ≥ 0.2V |
| Off threshold | ≤ 0.2V |

Tab. 16: Analog input signals

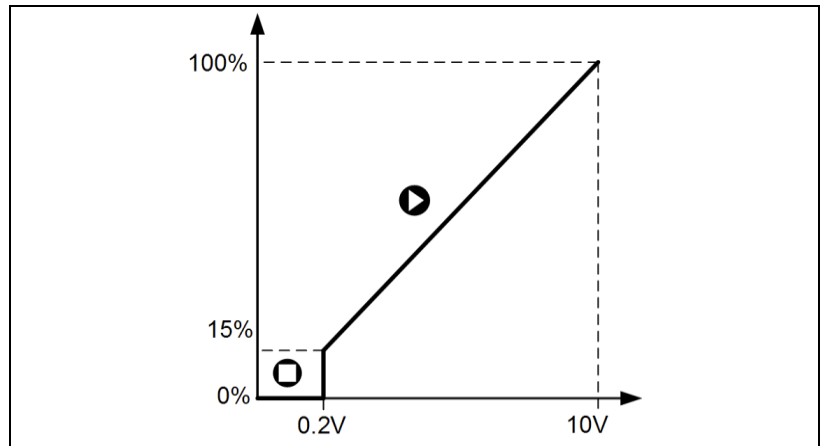

Fig. 20: range analog input

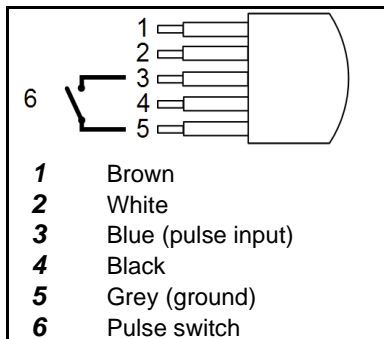

Fig. 21: Pulse input

8.2 Start/Stop pulse input

The pump can be externally started and stopped via the pulse input.

- ➔ The falling signal edge at the pulse input triggers the starting or stopping of the pump.
- ➔ If analog actuation is also used, a valid analog signal must be present.

Control signals

| Input | Meaning | Signal |
|-------------------|---|-------------------------|
| Pulse | Start/Stop on signal pulse | Falling edge below 4.0V |
| Pulse duration | Maximum pulse duration | 200 ms |
| Activation time | Minimum delay between activation pulse and deactivation pulse | 300 ms |
| Deactivation time | Minimum delay between deactivation pulse and activation pulse | 400 ms |

Tab. 17: Signal pulse input

- i** Following a pulse, there must be a delay before a new pulse is sent. See Tab 17.
- i** The pulse duration must not be longer than 200 ms.
- i** The use of debounced switches is recommended.

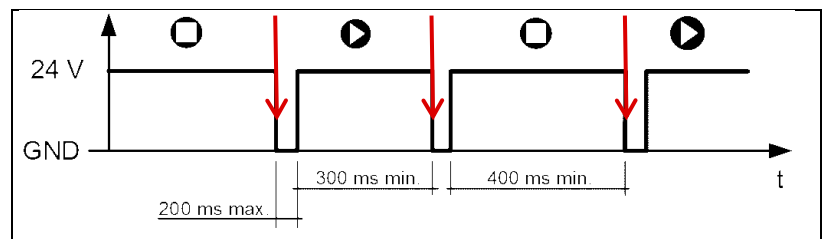

Fig. 22: Start/stop impulse control

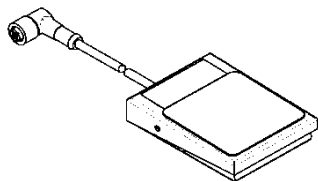

Fig. 23: Foot switch

Foot switch

With the RC version, the pulse foot switch (KNF Id. no. 155872) can be connected to the RC connector as an accessory.

- ➔ When the foot switch is operated, the pulse signal is shorted to ground, which switches the pump on.
- ➔ If it is operated again, the pump is switched off.

i The minimum switching times must be taken into consideration when the foot switch is operated. See Chapter 8.2

i The pump can also be switched on or off using the Start/Stop button at any time.

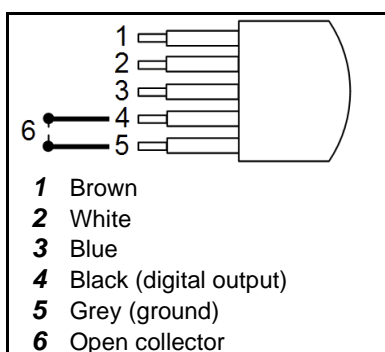

Fig. 24: Digital output

8.3 Digital output

The current operating status of the pump can be read out via the digital output.

The open collector is only switched on if the pump is transferring.

i The open collector output is internally connected to the collector of an NPN transistor (BC817-40) and to the internal 24V feed via a diode.

A maximum of 24V may be connected to the output.

The maximum current via the open collector must be limited to 10mA.

8.4 Shutting down the pump in an emergency

In order to shut the pump down in an emergency, pull out the mains plug. Or shut the pump down using the "Stop" button.

9. Cleaning and maintenance

9.1 Safety



⚠ DANGER

Danger of injuries caused by hazardous materials
 Poisoning and caustic burns caused by contact with aggressive, flammable or radioactive media

- Flush the pump thoroughly (see Section 9.3)
- Decontaminate the pump if necessary
- Observe the safety data sheets for the media to be transferred
- Wear suitable protective equipment



⚠ WARNING

Danger of heat build-up as a result of chemical reactions with the flushing liquid
 Significant heat build-up will damage the diaphragm, O-rings and valve system, resulting in leaks

- Avoid chemical reactions in the pump
- Observe the safety data sheets for the liquid to be transferred
- Observe the following advice

The following requirements apply to all the activities described in this chapter:

Requirements
 Personnel
 Personal protective equipment

- None
- Specialist personnel
- The type of protective equipment required will depend on the medium to be transferred.
- Observe the safety data sheets for the media to be transferred.

Spare parts Use only genuine parts from KNF for servicing work.

9.2 Maintenance plan

| Component | Servicing interval |
|--------------------|--|
| Pump | - Regular inspection for external damage or leaks |
| Pump head | - Clean if the flow rate decreases, the pump does not work or no vacuum is created - Replace parts if necessary See Chapter 12 |
| Pump diaphragm | - Replace pump diaphragm if the pumping capacity decreases or a leak occurs - Replace pump diaphragm in the event of repeated head installation |
| Filter (accessory) | - Replace if it is dirty |

Tab. 18: Servicing schedule

9.3 Cleaning the pump

In order to maintain the service life of the pump, after each use and before any long periods of inactivity the pump must be flushed through with neutral media.

IMPORTANT:

To ensure satisfactory start-up when the unit is restarted, it is important to ensure that the pump is free of any crystallising, adhesive or curing media.

9.3.1 Acids

- Flush pump with a suitable neutralising liquid in a circular flow for 10 minutes
- Then flush with distilled water for 5 minutes

9.3.2 Bases

- Flush pump with a suitable neutralising liquid in a circular flow for 10 minutes
- Then flush with distilled water for 5 minutes

9.3.3 Organic solvents

- Flush pump with isopropyl alcohol (C₃H₈O) in a circular flow for 10 minutes

NOTE

Never flush non-polar solvents immediately with water

9.3.4 Biological solution

- Flush pump with 10% hydrogen peroxide in a circular flow for 10 minutes
- Then flush with distilled water for 10 minutes

NOTE

The procedure described in Section 9.3.4 is not a sterilisation

9.4 Cleaning / replacing valve plates and pump diaphragm



⚠ DANGER

Danger from hazardous materials

Poisoning and caustic burns or undesirable reactions caused by escaping hazardous materials as a result of incorrect maintenance/servicing or the transferring of incompatible media.

- Follow the maintenance instructions
- Ensure cleanliness during maintenance (particles on seal faces cause leaks)
- Check that pump and system are leak-tight after maintenance



⚠ WARNING

Danger of poisoning and caustic burns

If they come into contact with skin and eyes, aggressive media cause poisoning and caustic burns.

- Cleaning the pump according to chapter 9.3
- flashing
- Wear protective equipment, e.g. protective gloves, safety glasses.

Requirements

- The pump must be switched off and disconnected from mains
- The pump must be free of any hazardous substances
- The hoses must be disconnected from the pump head
- Specialist personnel

Personnel

Personal protective equipment

- The type of protective equipment required will depend on the medium to be transferred.
- Observe the safety data sheets for the media to be transferred.

Tools and materials

| Qty | Tools/materials |
|-----|---|
| 1 | T20 Torx screwdriver |
| 1 | Phillips screwdriver no. 2 |
| 1 | Spare parts kit (see Chapter 12) |
| 1 | Torque screwdriver that can be set to 1.5 Nm. |

Tab. 19: Tools/materials

Information on procedure

Always replace valve disks, valve seats and seals at the same time to maintain a satisfactory flow rate.

9.4.1 Dismantling the pump head

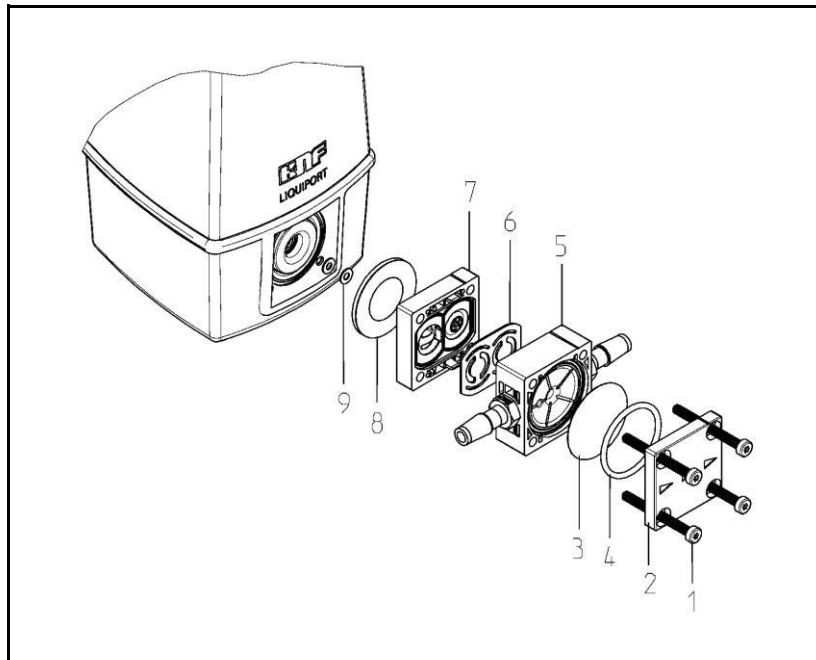

Fig. 25: LIQUIPORT100

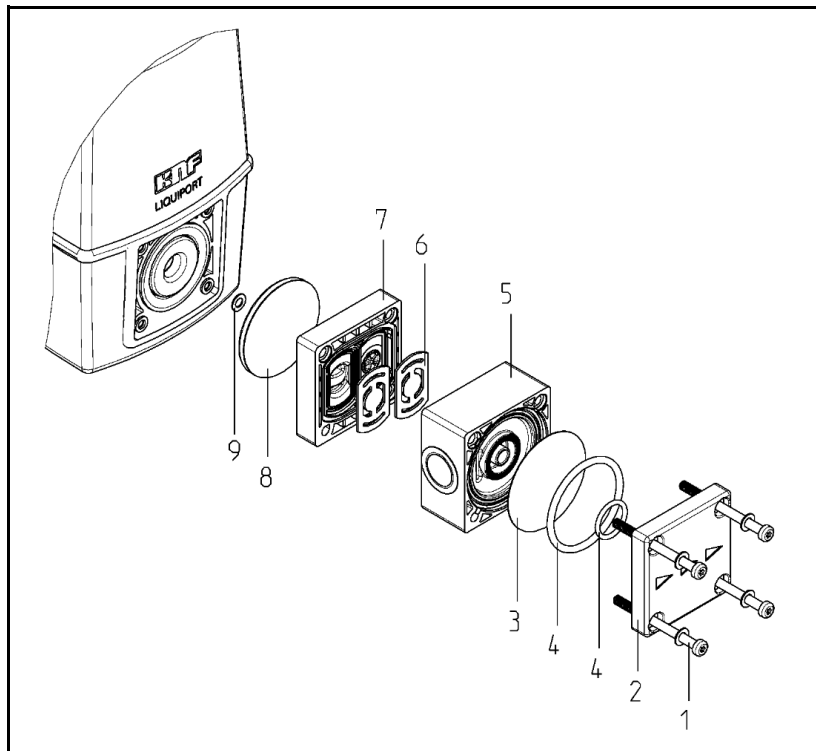

Fig. 26: LIQUIPORT300

1. Loosen the four head screws (1) and remove the entire head.

9.4.2 Removing the valves and seals

2. Remove the connecting plate (5) from the intermediate plate (7).
3. Take the valve plate (6) out of the intermediate plate (7).
4. Remove the resonating diaphragm (3) from the connecting plate (5).
5. Remove the O-ring (4) from the head plate.
6. Carefully grip the diaphragm (8) and remove by turning anti-clockwise. Remove the washers (9) and make sure that no washers 9 fall into the pump housing.

We recommend replacing the diaphragm (8).

9.4.3 Cleaning the parts

7. Clean the diaphragm (8), O-ring (4), resonating diaphragm (3), valve plate (6), intermediate plate (7) and connecting plate (5) with a cloth and then blow off with compressed air.

9.4.4 Installing the diaphragm

8. Place the same number of washers on the connecting rod (9) as were there previously. Make sure that no washers (9) fall into the pump housing.
9. Screw in the diaphragm (8).
10. By lightly pressing on the diaphragm push the ridge on the underside of the diaphragm into the groove of the housing.

9.4.5 Installing the valve plate

11. Place the dust-free valve plate(6) into the intermediate plate (7), making sure it is in the correct position.

9.4.6 Installing the pump head

12. Insert the resonating diaphragm (3) in the connecting plate (5) and cover with the head plate (2) fitted with a new O-ring (4).
13. The positions of the intermediate plate (7), the connecting plate (5) and the head plate (2) with respect to one another are determined by the arrangement of the visible grooves.
14. Insert the four head screws (1) into the through holes of the pump head.
15. Make sure that the flow direction of the pump head (see directional arrow on the head plate (2)) is the same as previously.
16. Place the pump head onto the pump housing and alternately tighten the four head screws (1). The maximum tightening torque is 1.5 Nm.
17. Check that pump and system are leak-tight after maintenance.

9.5 Checking that pump is leak-tight

⚠ WARNING



Danger of fluid system bursting due to overpressure.

The pump builds up pressure. In a closed system the max. permitted operating pressure may be exceeded, thus causing damage to the pump and/or the system.

- In the case of parts that are in contact with the fluid, use only those that are designed for the pump's operating pressure
- Do not transfer media against shut-off elements or closed systems, otherwise
- install pressure relief/safety valve and set to 6 bar (in the KNF product range)

In order to ensure correct assembly and hence reliability, it is essential to perform a leak test.

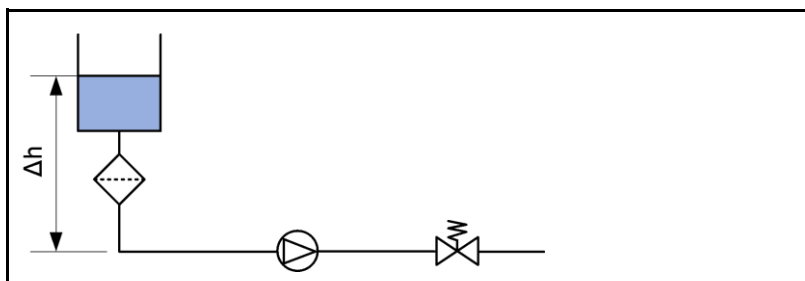

Fig. 27: Pressure test setup

1. Set up the system as shown in Fig. 27.
2. Use distilled water as a test medium.
3. Set pressure control valve to working pressure.
4. Make sure that the fitting is leak-tight (see Section 6.2.2).
5. Operate pump carefully for 5 minutes.
6. Check pump for leaks.

If no traces of medium are visible on the head, the pump can be used in accordance with its specification (see Chapter 3).

Caution!

If it is found that liquid is escaping, under no circumstances should the pump continue to be used.

1. Check that connections are leak-tight.
2. Check tightening torque of head screws.
3. Check that elastomer parts are clean.
4. Check leak-tightness again.

If these actions have no effect, contact your local KNF dealer and do not under any circumstances continue to use the pump.

10. Shutdown

10.1 Safety



! DANGER

Danger of injuries caused by hazardous materials

Poisoning and caustic burns caused by contact with aggressive, flammable or radioactive media

- Flush the pump thoroughly (see Section 9.3)
- Decontaminate the pump if necessary
- Observe the safety data sheets for the media to be transferred
- Wear suitable protective equipment

The following requirements apply to all the activities described in this chapter:

Requirements
 Personnel
 Personal protective equipment

- System depressurised
- Specialist personnel
- The type of protective equipment required will depend on the medium to be transferred.
- Observe the safety data sheets for the media to be transferred.



10.2 Procedure

1. Flush the whole system including the pump with a neutral liquid
2. Pump the pump empty (see Section 9.3)
3. Press the STOP button to end the transferring operation
4. Unplug the pump from the power supply
5. Dispose of pump properly

11. Troubleshooting

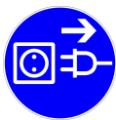

11.1 Safety

Disconnect the mains plug from the power supply before working on the pump head.

- | | |
|-------------------------------|---|
| Requirements | ▪ Pump has been thoroughly flushed/decontaminated |
| Personnel | ▪ Specialist personnel |
| Personal protective equipment | ▪ None |

Pump does not transfer

| Cause | Remedy |
|--|--|
| Pump not connected to the power supply. | Connect pump to the power supply. |
| No voltage in the power supply. | Check room fuse and switch on if necessary. |
| Connections or hoses are blocked. | Check connections and hoses. Remove blockage. |
| External valve is closed or filter is clogged. | Check external valves and filters. |
| Worn diaphragm or valve plates/seals. | Replace diaphragm and valve plates/seals (see Section 9.4). |
| External actuation connected without a signal | Check external actuation signal. |
| Pump overload protection has tripped. - Flow rate indicator flashing - Standby indicator not illuminated | Pump unable to build up counterpressure Pump transferring against pressure that is too high Reduce pressure in system Reduce flow rate |
| Overheating of the pump - The delivery rate display flashes - The standby indicator lights up | The integrated thermal switch has switched off the motor. The pump can be started again after cooling down. This can take a few minutes. Press the start/stop button for restart. |

Tab. 20: Pump does not transfer

¹⁾ Maximum pressure build-up depends on flow rate setting.
Please note: Pump not protected from overpressure.

11.2 Rectifying transfer problems

Flow rate, pressure, or vacuum are too low

The pump does not achieve the performance stated in the technical data or on the data sheet.

| Cause | Remedy |
|---|--|
| Presence of positive pressure on the pressure side with simultaneous vacuum or positive pressure on the suction side. | Change pressure conditions. |
| Cross-section of hydraulic hoses or connectors too narrow or restricted. | Disconnect the pump from the system and determine output values. Remove restriction (e.g. valve) if necessary. If applicable, use larger-diameter hoses or connectors. |
| Leaks in connections, hoses or pump head. | Repair leaks. |
| Connections or hoses completely or partially obstructed. | Check connections and hoses. Remove any parts or particles causing blockages. |
| Pump head components are soiled. | Clean head components. |
| Worn diaphragm or valve plates/seals. | Replace diaphragm and valve plates/seals (see Chapter 9.4). |
| Materials chemically damaged by transferred media. | Select a type of material that is resistant and suitable. |

Tab. 21: Flow rate, pressure, or vacuum are too low

Fault cannot be rectified

If you are unable to identify the cause of the problem, please send the pump to KNF customer service (see address on last page).

1. Flush the pump to clear the pump head of any hazardous or aggressive liquids (see Section 9.4).
2. Dismantle the pump.
3. Clean the pump (see Section 9.3).
4. Send the pump, with completed decontamination declaration (see Chapter 13), to KNF customer service stating the nature of the transferred medium (see arranging for return).

12. Spare parts and accessories

12.1 Spare parts

| Spare parts | Order No. |
|--|-----------|
| LIQUIPORT 100 spare parts kit KT head | 065262 |
| LIQUIPORT 100 spare parts kit TT head | 065262 |
| LIQUIPORT 100 spare parts kit FT head 1) | 152631 |
| | |
| LIQUIPORT 1.100 spare parts kit KT head | 065262 |
| LIQUIPORT 1.100 spare parts kit TT head | 065262 |
| LIQUIPORT 1.100 spare parts kit FT head 1) | 152631 |
| | |
| LIQUIPORT 300 spare parts kit KT head | 068691 |
| LIQUIPORT 300 spare parts kit TT head | 068691 |
| LIQUIPORT 300 spare parts kit FT head 1) | 151902 |
| | |
| LIQUIPORT 1.300 spare parts kit KT head | 069728 |
| LIQUIPORT 1.300 spare parts kit TT head | 069728 |
| LIQUIPORT 1.300 spare parts kit FT head 1) | 151903 |

Tab. 22: Spare parts

1) The FT head is not compatible with the KT/TT pump housing.

12.2 Accessories

| Connection nipples | Order No. |
|--|-----------|
| Spare parts kit screw-in nipples NPT1/8 ETFE/FFKM | 168547 |
| Spare parts kit screw-in nipples NPT3/8 ETFE/FFKM | 168551 |
| Spare parts kit screw-in nipples NPT1/8 ETFE/EPDM | 168555 |
| Spare parts kit screw-in nipples NPT3/8 ETFE/EPDM | 168549 |

Tab. 23: Connection nipples

| Foot switch | Order No. |
|-----------------------------|-----------|
| LIQUIPORT pulse foot switch | 155872 |

Tab. 24: Foot switch

| Fasteners | Order No. |
|----------------|-----------|
| Tripod holder | 160474 |
| Mounting plate | 160473 |

Tab. 25: Fasteners

13. Decontamination declaration

| |
|--|
| NOTE |
| KNF shall only undertake to repair the pump on condition that the customer provides certification of the transferred media and the cleaning of the pump (decontamination declaration). |

KNF Flodos AG
 Wassermatte 2
 6210 Sursee, Switzerland
 Tel +41 (0)41 925 00 25
 Fax +41 (0)41 925 00 35
 www.knf.com

1. Copy this page, or print out the decontamination declaration from our website <http://www.knf.com/downloads>.
2. Enter the pump model, the serial no. and the transferred media in the form below and send the signed form together with the flushed and cleaned pump to KNF customer service.

Customer decontamination declaration for repair order

We confirm that the pump below has been used to transfer the following media, and that the pump has been flushed and cleaned.

| | |
|-------------------|--|
| Pump model | |
| Serial no. | |
| Transferred media | |
| | |
| | |
| | |
| | |

The pump does not contain aggressive, biological, radioactive, poisonous, or other dangerous media.

.....
 Company

.....
 Date/Signature

