

IKA

designed for scientists

VC 10 lite VC 10 pro



Betriebsanleitung	DE	5
Ursprungssprache		
Operating instructions	EN	29
Mode d'emploi	FR	53
Руководство пользователя	RU	77
使用说明	ZH	101

Breve guía	ES	124	Bezpečnostné pokyny	SK	141
Brevi istruzioni	IT	125	Ohutusjuhised	ET	142
Veiligheidsaanwijzingen	NL	127	Drošības norādījumi	LV	144
Säkerhetsanvisningar	SV	128	Saugos nurodymai	LT	145
Sikkerhedshenvisninger	DA	130	Инструкции за безопасност	BG	146
Sikkerhetsinformasjon	NO	131	Indicații de siguranță	RO	148
Turvallisuusohteet	FI	132	Υποδείξεις ασφαλείας	EL	150
Instruções de segurança	PT	134	Güvenlik talimatları	TR	151
Wskazówki dotyczące bezpieczeństwa	PL	135	안전 지침	KO	153
Bezpečnostní pokyny a informace	CS	137	安全上の注意	JA	154
Biztonsági utasítások	HU	138	คำแนะนำเกี่ยวกับความปลอดภัย	TH	155
Varnostna navodila	SL	139	Petunjuk keselamatan	ID	157

Contents





	Page
Device setup	2
Declaration of conformity	29
Explication of warning symbols	29
Warranty	29
Safety instructions	30
Unpacking	31
Intended use	31
Useful information	31
Setting up	33
Commissioning	36
Interfaces and outputs	46
Maintenance and cleaning	47
Error codes	48
Accessories	49
Product contact parts	49
Technical data	50

Declaration of conformity

We declare under our sole responsibility that this product corresponds to the regulations 2014/35/EG, 2014/30/EG and 2011/65/EG and conforms with the standards or standardized documents EN 61010-1, EN 60529, EN 61326-1 and EN ISO 12100.

A copy of the complete EU Declaration of Conformity or further declarations of conformity can be requested at sales@ika.com.

Explication of warning symbols

 DANGER	Indicates an (extremely) hazardous situation, which, if not avoided, will result in death, serious injury.
 WARNING	Indicates a potentially hazardous situation, which, if not avoided, can result in death, serious injury.
 CAUTION	Indicates a potentially hazardous situation, which, if not avoided, can result in injury.
 NOTICE	Indicates practices which, if not avoided, can result in equipment damage.

Warranty

In accordance with warranty conditions, the warranty period is 24 months. For claims under the warranty please contact your local dealer. You may also send the machine direct to our factory, enclosing the delivery invoice and giving reasons for the claim. You will be liable for freight costs.

The warranty does not cover worn out parts, nor does it apply to faults resulting from improper use, insufficient care or maintenance not carried out in accordance with the instructions in this operating manual.

Safety instructions

For your protection



NOTICE

Read the operating instructions in full before starting up and follow the safety instructions.

- Keep the operating instructions in a place where it can be accessed by everyone
- Ensure that only trained staff work with the instrument.
- Follow the safety instructions, guidelines, occupational health and safety and accident prevention regulations.



DANGER

Always wear personal protective equipment in accordance with the hazard class of the media being worked with, otherwise there is a risk of splashing liquids, release of toxic or inflammable gases!

- The device and device parts must not be used on humans or animals.
- Do not expose parts of the human body or animals to the vacuum.
- Position the device as specified in the "Commissioning" section and connect the connection cables and interfaces as described.
- Never work with an incorrectly connected or defective device.
- Inhalation of or contact with media such as poisonous liquids, gases, spray mist, vapours, dusts or biological and microbiological materials can be hazardous to user. Make sure that all connections are tight and leak-free when working with such media.
- Prevent the release of the above mentioned substances. The use of suitable extraction systems e.g. fume cupboards is recommended in the place of installation. Take protective measures for personnel and the environment.
- Due to the residual leakage rate of the device, this can result in the release of medium.
- The VC 10 lite/pro vacuum controller is not designed to be installed in potentially explosive atmospheres
- The VC 10 lite/pro vacuum controller is not designed for use with self inflammable substances, substances which are inflammable without air or explosive substances.
- Take suitable precautions to prevent any formation of explosive mixtures. Use inert gas for venting and/or dilution, if necessary.
- Take into consideration interactions or possible chemical or physical reactions when working with media under reduced pressure and elevated temperature.
- Never work with the device under water or underground.
- The device must only be operated with supervision.
- Electrostatic events can occur between the medium and device and lead to a direct hazard.
- Safe operation is only guaranteed with the accessories described in the "Accessories" section.
- The instrument can only be disconnected from the mains supply by pulling out the mains plug or the connector plug.
- The socket for the mains cord must be easily accessible.
- Do not use the device if the AC adapter is defective.
- Follow the operating instructions of the additional equipment carefully (e.g. a rotary evaporator, vacuum pump) with which the VC 10 lite/pro vacuum controller is operated.

- The VC 10 lite/pro vacuum controller may only be operated under the conditions described in the "Technical data" chapter.
- The pressure at the gas inlet and gas outlet must not exceed 1100 mbar. For pressure over 1100 mbar, the total allowable pressure is exceeded and the device no longer displays the pressure accurately.
- Only use flexible hose lines.
- Flexible elements can be compressed under vacuum.
- In the event of a power failure, the integrated venting valve automatically aerates the connected recipient.
- Be aware of your emergency measures in the event of a power failure and ensure that the system is put into a safe state.
- The safety of the user cannot be guaranteed if the appliance is operated with accessories that are not supplied or recommended by the manufacturer or if the appliance is operated improperly, contrary to the manufacturer's specifications or if the instrument or the printed circuit board are modified by third parties.

For protection of the equipment



CAUTION

The voltage stated on the type plate must correspond to the mains-voltage.

- Covers or parts that can be removed from the device without tools must later be refitted to ensure safe operation, so long as no other connection is made at this point. This will prevent the infiltration of foreign objects, liquids etc.
- The device must only be operated with the original plug-in power supply unit supplied.
- Protect the appliance and accessories from bumps and impacts.
- The appliance may only be opened by experts (authorized staff).
- To ensure sufficient cooling of the VC 10 lite/pro vacuum controller, the ventilation slots on the housing must not be covered.
- Use only original spare parts for repair and maintenance in order to ensure the reliable operating condition of the device.
- Pay attention to water condensation inside and outside of the device. If the device is brought from a cold environment, allow the device to warm up.
- Never attach the vacuum controller above a heating bath.
- Ensure that no solids and/or liquids enter the VC 10 lite/pro vacuum controller via the suction power of the pump. This will result in damage to the pressure sensor and the valves.



WARNING

Check the compatibility of the substances used with the device with the materials listed under "Product contact parts"; see chapter "Product contact parts".





- Place the VC 10 lite/pro vacuum controller in an elevated position if possible, so that in the event of a fault, no condensate can collect on the pressure sensor.

Unpacking

Unpacking

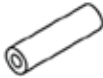
- Please unpack the device carefully.
- In the case of any damage a detailed report must be sent immediately (post, rail or forwarder)

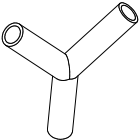
Delivery scope

Vacuum controller VC 10 lite/pro		Vacuum hose 1 m		Fig. 4
Universal plug-in power supply unit		Y connector		Fig. 5
USB A - micro B cable		Operating instructions		
		Warranty card		

Intended use

Use

Together with the accessories recommended by , the VC 10 lite/pro vacuum controller is suitable for the controlled evacuation of air (gas) from laboratory devices and equipment (e.g. rotary evaporator or laboratory reactors, and also for classical separation or filtration or drying tasks in the laboratory) in conjunction with a suitable vacuum source (e.g. MVP 10 basic / VACSTAR). The VACSTAR can be operated automatically with the VC 10 pro

vacuum controller.

Therefore, it can be used for automatic boiling point recognition, programmed pressure-time curves or programs from the solvent library, for example.

Mode of operation: Stand device

Area of use

Indoor environments similar to that a laboratory of research, teaching, trade or industry area.

The safety of the user cannot be guaranteed:

- If the device is operated with accessories that are not supplied or recommended by the manufacturer;
- If the device is operated improperly or contrary to the manufacturer's specifications;
- If the device or the printed circuit board are modified by the third parties.



WARNING

The device must not be used for:

- **vacuation of biological biotopes,**
- **evacuation of explosive, corrosive or gas volumes,**
- **throughput/use of fluids!**

Useful information

In addition to a high-resolution Al_2O_3 pressure sensor, the VC 10 lite/pro vacuum controller has an integrated vacuum valve and a venting valve. As a result, the VC 10 lite/pro vacuum controller can be used without any additional peripheral devices.

The VC 10 pro provides two basic modes of operation: Two-position control and analogue speed control.

The change between the two modes is performed automatically by plugging or unplugging the connector cable at the "VACSTAR" interface. Depending on the selection made, some submenu items may not be available (greyed out on the display).

With two-position control, parameters from the solvent library can be applied or target values specified in manual mode.

With analogue speed control, an automatic mode as well as the setting of the percentage pump speed can also be preset. Space requirement: To connect all peripheral devices you will need approximately WxDxH 150 x 200 x 155 mm³ space for the device with connected plugs.

Two-position control VC 10 pro (only)

A vacuum is made in the glassware with the help of a vacuum pump. The vacuum pump operates at constant speed which generally cannot be adjusted. Once the target value setting is reached, the integrated vacuum valve interrupts the suction line.

The device will fall slightly short of the target value setting due to the time difference in the millisecond range with the vacuum valve, the target value comparison and the switching of the vacuum valve. Natural leakage from the apparatus now causes another increase in the pressure value of the system, which in turn is detected by the integrated pressure sensor.

If the target value is exceeded, the vacuum valve is reopened and the vacuum pump in operation lowers the pressure. The pressure curve shown on the display fluctuates around the set target value. The pressure difference between activating/deactivating the valve can be set using the vacuum hysteresis value.

The quality of the control depends on the suction power of the pump (rotation speed), the tightness of the system and signal delay time of the electronics used.

Analogue speed control

Imprecision of the two-position control is avoided by using the analogue speed control.

With this kind of control, the speed of the pump, and therefore its suction power, is reduced the closer the measured pressure reaches the target value. Once the target value is reached, the pump only operates according to the leakage rate of the system. This type of control offers quieter operation, more exact vacuum control and a long service life of movable pump parts.

Automatic boiling point recognition is possible with this type of control, i.e. the system reaches and keeps the solvent at its boiling point in automatic mode.

Analogue speed control with the VACSTAR:

The VACSTAR is automatically detected as soon as the connection cable is plugged into both devices. The analogue speed control is enabled, the two-position control is disabled and cannot be selected.

Menu items such as automatic boiling point recognition, programmed pressure-time curves or programs from the solvent library can be used.

Refer to the operating instructions for the VACSTAR vacuum pump.

Schematic view of speed-vacuum control

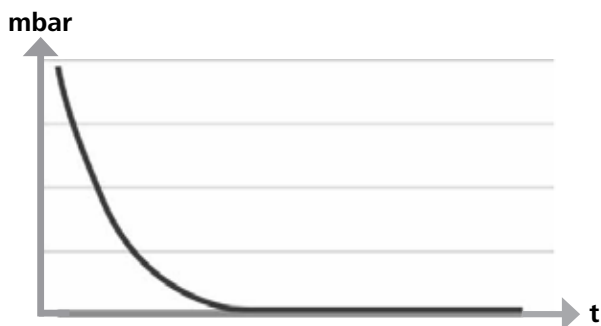

Automatic boiling point recognition is not possible when using two-position control.

Schematic view of a two-position vacuum control

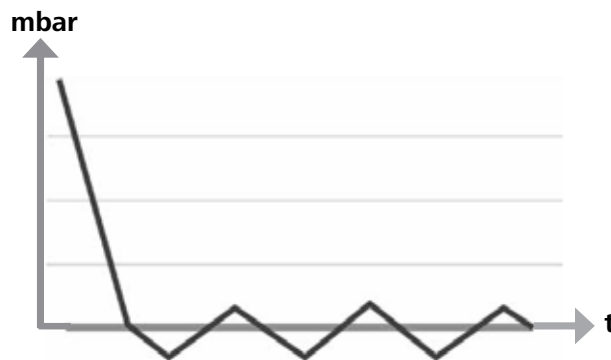

*An external temperature sensor can be connected to the "PT1000" temperature sensor interface. When the menu view is enabled, the temperature value is shown in the display.

Time sequences can be controlled using a timer.

The operating modes A, B, C and D have preset access options for adjusting and saving target values.

Display settings can be changed using the "Display" menu item.

Access to the device can be restricted by setting up a password in the "Security" menu item.

Common settings such as language, pressure and temperature units can be set via the "Settings" menu item. The display background can also be changed from black to white as well as brightness settings adjusted.

The integrated solvent library calculates the theoretical boiling point at a specified steam temperature value, or vice versa.

The upper and lower limits or the switching points of the vacuum control can be set in the submenu items "Limit values" and "Hysteresis".

**only VC 10 pro*

Setting up



NOTICE

Observe the general information, always connect the recipients (load/vacuum vessel/glass cooler) at their highest points to the suction line. This will prevent the risk of fluid entering into the vacuum controller or pump.

Install a separator (e.g. Woulff bottle) in front of the intake mounting to protect against the ingress of liquid.

In the case of induced solvent vapours, a vapour condenser (accessory of pump) installed downstream of the pump helps to condense the vapours and prevents release into the atmosphere.

Liquid in the pump chambers deteriorates the pump characteristics.

Attach the VC 10 lite/pro vacuum controller to a stand (d=16 mm) close to the pump.

Secure the controller with the stand locking screw (N).



Fig. 5

To do so, use a stand with diameter 16 mm, for example, stand VC 10.400, VSS 1 vacuum safety set, the stand on VACSTAR vacuum pump or attach the controller to the RV 8 rotary evaporator, or at LR 1000 laboratory reactor.



Fig. 6

VC 10 lite/
pro at stand
VC 10.400



Fig. 7

VC 10 lite/pro to VSS 1 with MVP
10 basic



Fig. 8

VC 10 lite/pro to VACSTAR



Fig. 9

VC 10 lite/pro
to RV 8

Connecting the interfaces

Connect the vacuum hoses, pay attention to the following connections (also see **Fig. 1**):

J: Load

Hose connection d=10 mm to the system to be evacuated (recipient).

K: Pump

Hose connection d=10 mm to the vacuum source (e.g. pump).

L: Vent

Ventilation connection d=10 mm, also suitable for the connection of inert gas.

Secure the hoses with hose clamps, if necessary.

Lay the vacuum hoses according to your device configuration.

Now connect the connecting cables according to your system configuration:

L: Mini USB Interface

Connect the VC 10 lite/pro vacuum controller to a PC using the USB 2.0 cable (A/Micro-B).

Software updates to any existing equipment can be installed using the FUT software tool.

M: RS 232 Interface

You can connect the VC 10 lite/pro vacuum controller to a PC using an RS 232 interface cable. The pump can be operated in conjunction with other devices using labworldsoft® laboratory software. For more information see Chapter "Interfaces and outputs".

P: PT 1000 temperature sensor (VC 10 pro)

Connect the optional PT 1000.60, PT 1000.61 or PT 1000.70 temperature sensor (accessory). The measured temperature (e.g. tempering bath) is shown on the display.

The value displayed is for information purposes only and is not processed logically.

Note that the value displayed is dependent on the positioning of the sensor in the medium, its mixing, as well as the calibration of the probe and can deviate from other measured temperature values.

Incorrect or fluctuating measured values can be displayed by using a heating bath, e.g. by laying the sensor on the heating bath floor, instead of positioning in the medium.

Q: VACSTAR membrane vacuum pump (Mini DIN)

You can connect the vacuum controller and the VACSTAR vacuum pump to the analogue connection cable (accessory) for exact speed-controlled vacuum control. The vacuum controller detects the pump and switches to speed-vacuum control mode. The two-position control is disabled. The pump speed is regulated depending on the measured pressure.

R: Connector for 24 W AC adapter

Connect the universal AC adapter (included) to the socket on the rear. Observe the country-specific variants of the AC adapter!

Explanation of abbreviations used in the following schematic drawings and configurations:

- 1 Recipient (load, e.g. rotary evaporator, reactor)
- 2 Separator (Woulff bottle)
- 3 Venting valve
- 4 Pressure sensor
- 5 Vacuum valve/ball valve
- 7 Vapour condenser
- 8 Connection cable (analogue)
- 9 Vacuum source (pump, in-house vacuum)
- 10 VC 10 lite/pro.300 Check valve

Two-position control

Vacuum pump/vacuum source with VC 10 pro vacuum controller.

Once the target value is reached, the suction line is closed by the vacuum valve integrated in the VC 10 pro vacuum controller. The pump speed can be changed by manually adjusting the speed setting.

For pumps which have the speed setting option, it is recommended to work at low speed.



NOTICE

When using the VACSTAR vacuum pump: The pump must be operated in mode "B" (restart after voltage drop).

The vacuum source can also be a central in-house vacuum network.

Illustration two-position control - vacuum pump/vacuum source with vacuum controller VC 10 pro

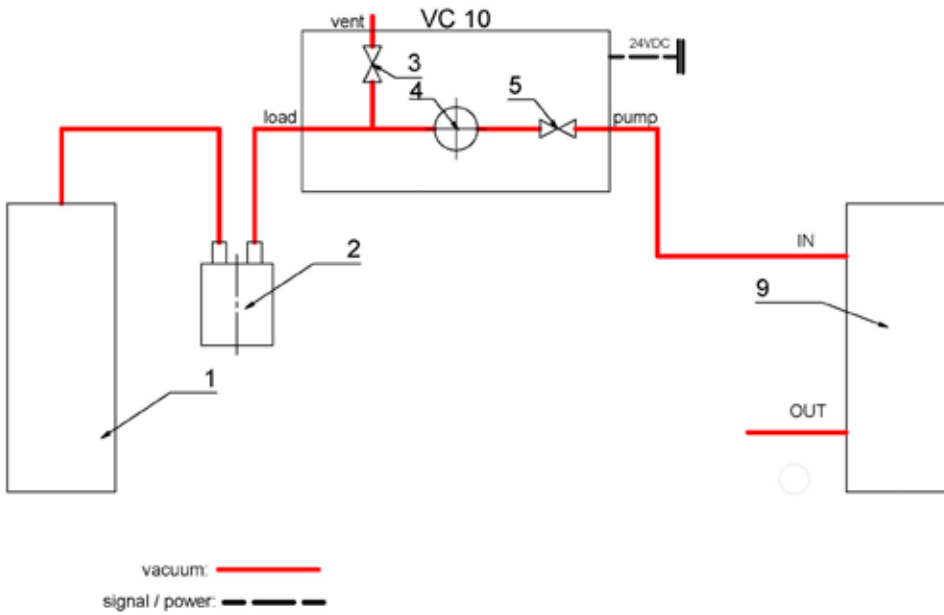

Vacuum source with two VC 10 pro vacuum controllers.

Once the target value is reached in a recipient, the suction line is closed by the vacuum valve integrated in the VC 10 pro vacuum controller.

A sufficiently stable vacuum source (in-house vacuum, pump) can serve multiple consumers.

For pumps which have the speed setting option, it is recommended to work at low speed.

A second consumer can be controlled independent of the first using a second vacuum controller.

Illustration two-position control - vacuum source with two vacuum controllers VC 10 pro

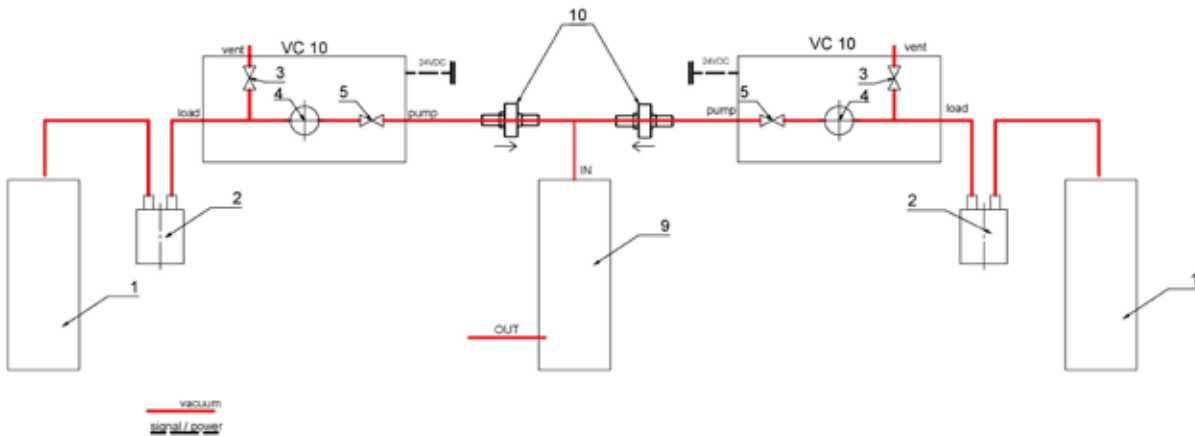

Speed control

VACSTAR vacuum pump with VC 10 lite/pro vacuum controller

Automatic adjustment of the “analog speed control” mode if the analogue connection cable (Pos. 8) is connected to the pump with the vacuum controller.

Once the target value is reached the pump speed is automatically reduced to a minimum “0 rpm”. Once the target value is reached,

the pump operates according to the leakage rate of the vacuum system.

Automatic boiling point recognition is only possible with the VC 10 pro .

Illustration speed control - Vacuum pump VACSTAR with vacuum Controller VC 10 lite/pro

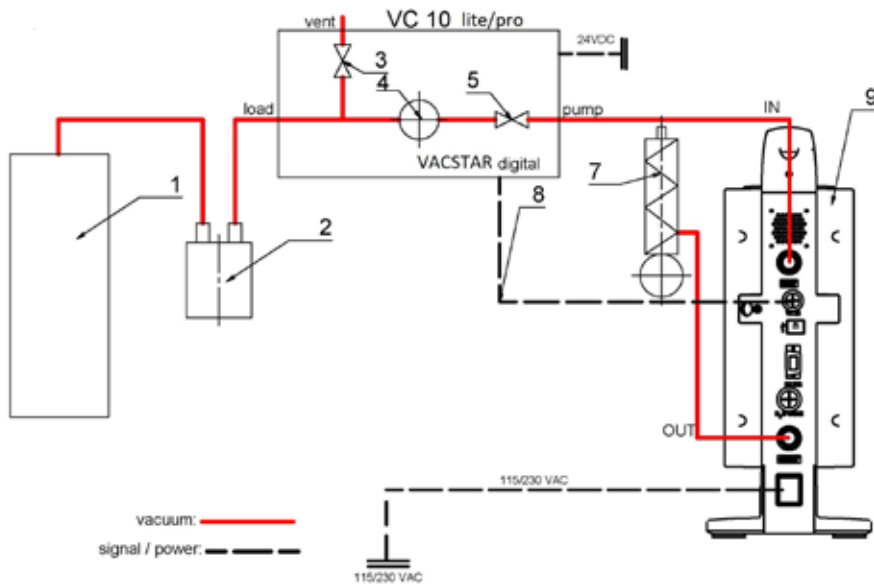

Commissioning

Check whether the voltage given on the type plate corresponds to the available mains voltage.

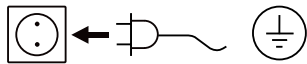

The socket used must be earthed (fitted with earth contact).

If these conditions have been met, the machine is ready for operation when the mains plug is plugged in.

If these conditions are not met, safe operation is not guaranteed and the machine could be damaged.

Also pay attention to the ambient conditions listed in the “Technical data”.

Start screen layout at the time of delivery



NOTICE

The start screen appears for a few seconds when the device is switched using the “Standby ON/OFF” switch (F) The device name and the software/firmware versions are also displayed.



An information prompt then appears to download the firmware update tool.

The following working screen appears automatically in the display.
Display of two-position control, e.g. with MVP 10 basic.

Hysteresis display for two-position control

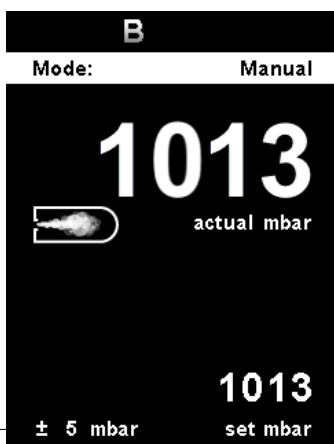

Display speed control: VACSTAR to analogue connection

No hysteresis display for speed control

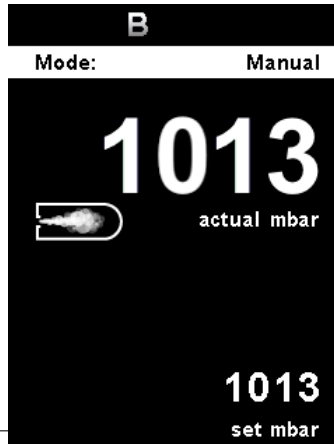

Explanation of symbols on the working screen

The symbols displayed change depending on the status and settings of the vacuum controller:



- Key** **Lock key**
 This symbol means that the function of the key and of the rotating/pressing knob for controlling the vacuum controller are disabled. The symbol no longer appears if the functions are enabled once again by pressing the lock key a second time (min. 1 sec.).
- A** **Operating mode**
 This symbol indicates the operating mode currently selected (A, B, C, D).
- USB**
 This symbol means the vacuum controller is communicating via a USB cable. The symbol no longer appears if no USB cable is being used for communicating with the station
- Temperature sensor (VC 10 pro)**
 This symbol appears when the temperature display is active in the display.
- Timer** This symbol appears when the timer display is active in the display.

- PC** **PC control**
 This symbol means that the vacuum controller is connected to a computer and the device is being controlled from the computer.
- PR** **Programm-Steuerung**
 This symbol means that the vacuum controller is connected to a computer and the device is being controlled from the selected program.
- Continuous mode**
 This symbol indicates that the vacuum controller is in continuous mode.
- Vent**
 This symbol indicates that venting is enabled.
- Vacuum**
 This symbol indicates that the current pressure is less than the existing atmospheric pressure.
- Detection**
 This symbol is displayed during the automatic boiling point search, the system pressure is reduced further.
- Boiling**
 This symbol indicates that a boiling point has been found automatically, the system pressure is kept constant.
- Refrigerated circulator**
 This symbol indicates that refrigerated circulator is operating.

Navigation menu



Fig. 9

- ☞ Press the **"Menu"** key (C).
- ☞ Select the menu by turning the rotating/pressing knob (D) to the right or left to select the desired menu or sub-menu, which can then be selected by pressing the rotating/pressing knob (D).
- ☞ Press or turn the rotating/pressing knob (D) again to select the desired menu option and edit the values or settings, or activate/deactivate a function.
- ☞ Turn the rotating/pressing knob (D) to **"OK"** and press the **"Back"** (B) or **"Menu"** key (C) to end the procedure and return to the previous menu or working screen.
- ☞ Navigating in Menu "Graph": Press the **"Back"** (B) at main screen to navigate to graph menu, showing real-time pressure change on graph.



NOTICE

The menu option activated is highlighted yellow in the display. Menus which are grayed out are inactive.

- Navigation menu:**
- ▼ Press the **"Menu"** key (C) and turn the rotating/pressing knob (D)
 - ▲ Press the **"Back"** key (B) or the **"Menu"** (C)

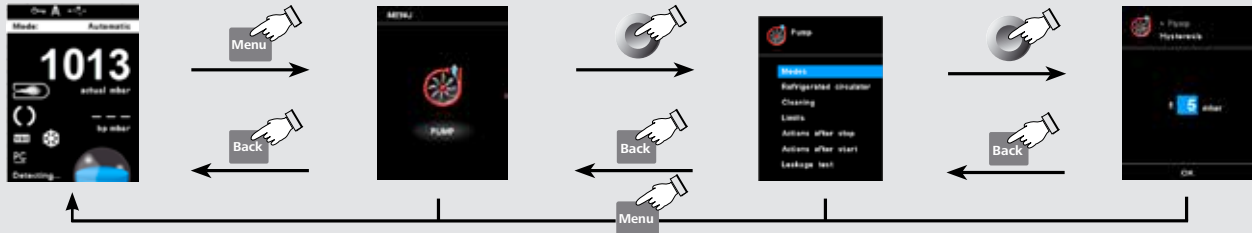

NOTICE

If you press the **"Menu"** key (C), the system skips directly back to the working screen.
If you press the **"Back"** key (B), the system skips back to the previous display.

Menu structure

Menu	Sub menu	Option	Action	Factory setting	
Pump	Modes	Automatic (only VC 10 pro).....		Deactivated	
		Manual.....		Activated	
		Pump %.....		Deactivated	
	Refrigerated circulator	Program.....		Deactivated	
		Start After.....		-	
		Temperature.....		-	
		Pump speed.....		-	
		Cool now.....		-	
		Stop now.....		-	
	Cleaning	Start after.....		05:00 [mm:ss]	
		Duration.....		06:00 [mm:ss]	
		Pump speed.....		20 %	
		Clean now.....		Deactivated	
	Limits	Manual	Minimum.....		1 mbar
			Maximum.....		1100 mbar
		Pump %	Minimum.....		0 %
			Maximum.....		100 %
	Hysteresis (VC 10 pro)	Automatic.....		Activated	
	Solvent library (VC 10 pro)	Manual.....		Deactivated	
		Acetonitril.....		-	
		N-Amylalkohol.....		-	
		n-Pentalon.....		-	
		Benzol.....		-	
	Actions after stop	Open venting valve.....		Activated	
		Cleaning.....		Deactivated	
		Stop refrigerated circulator.....		Deactivated	
	Actions after start	Turn on refrigerated circulator.....		Deactivated	
	Leakage Test	Leakage rate.....		3 mbar	
			1mbar		
Tolerance.....			500 mbar		
Test point.....			1 minute		
Leakage test duration.....					
Temperature (VC 10 pro)	Sensor temperature.....		-		
	Display.....		Deactivated		
	Calibration.....		20.0 °C		
Timer	Timer function	Time.....		00:00:01 [hh:mm:ss]	
		Beep after stop.....		Activated	
		Activate.....		Deactivated	
Display.....		Deactivated			
Operating mode	A.....		Deactivated		
	B.....		Activated		
	C.....		Deactivated		
	D.....		Deactivated		
Display	Timer.....		Deactivated		
	Temperature (VC 10 pro).....		Deactivated		
Programs	Program 01.....		-		
	...		-		
	Program 10	Select.....		-	
	Edit.....	Edit, insert, delete.....		-	
	Delete.....			-	
	Last measurement	Save as.....		-	
Edit.....	Edit, insert, delete.....		-		
Delete.....			-		
Safety	Password.....		0 0 0		
Service	Valves	Venting valve.....	Close, open.....	Open	
		Vacuum valve (VC 10 pro).....	Close, open.....	Close	
	Pump.....			Deactivated	
Refrigerated circulator.....			Deactivated		
Settings	Languages	English.....		Activated	
		German.....		Deactivated	
	Units	Pressure	mbar.....		Activated
			hPa.....		Deactivated
			mmHg.....		Deactivated
		Temperature (VC 10 pro)	Torr.....		Deactivated
			°C.....		Activated
			°F (not available for Japan).....		Deactivated
	Display	Background	Black.....		Activated
			White.....		Deactivated
	Brightness.....		100 %		
	Firmware update info.....		Activated		
	Sound	Volume.....		10 %	
		Key tone.....		Deactivated	
	Factory setting	Menu values.....	Reset to factory setting.....		-
Programs.....				-	
All.....				-	
Communication	Device name.....		VC 10 lite/pro		
Information	Firmware update info.....		-		
	Display version.....		-		
	Logic version.....		-		
	Operating mode.....		B		
	Pressure max.....		1100 mbar		
	Pressure min.....		1 mbar		
	Pump % max.....		100 %		
	Pump % min.....		0 %		

Menu details

Pump

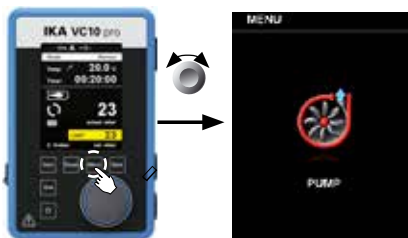

Modes

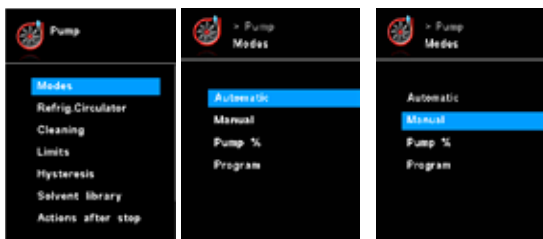

Automatic (VC 10 pro):

In the "Modes" menu, the user can enable automatic boiling point recognition by selecting the "Automatic" menu item. No other parameters must be set.

The boiling point is detected automatically. For rotary evaporators with heating bath, it must be ensured that the tempering medium and solvents have a constant temperature (e.g. 60 °C).

Manual:

In the "Manual" menu item, the target value can be specified (e.g. in "mbar"). The system is evacuated until the target value.

Refrigerated circulator

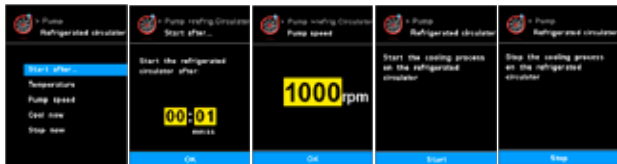

Start after...:

Specifies a delay before the refrigerated circulator start operating.

Temperature:

Determines the temperature, that the refrigerated circulator is operated.

Cleaning

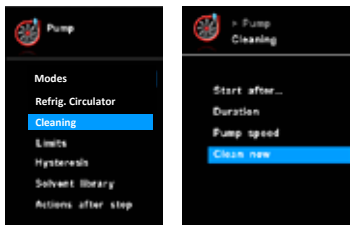

The cleaning of the pump ensures that solvent residues are removed in the pump after the measurement. For this purpose, the pump is operated at a low level while the system is vented. The air flowing through the pump ensures that the solvent residues are discharged from the pump. If the cleaning option is selected, this starts once the measurement has finished (see "Actions after stop").

Pump %

By selecting the "Pump %" menu item, the pump can be operated continuously with a running performance of between 100 % and 1 %.

Program

Under the "Programs" menu, 10 user-defined pressure-time profiles can be created. The last measurement taken can also be viewed in this menu and saved as a program.

The target value and the running performance can only be entered within the set limits (see menu item "Limits").

Changing to the working screen and pressing the rotating/pressing knob starts the process. Pressing the knob again stops the process.



NOTICE

If no speed-controlled pump with analogue connection is connected to the "VACSTAR" interface, the system can only work in manual mode and in "two-position control" mode. The menu items "Auto" and "Pump %" are greyed out and cannot be activated.

Pump speed:

Determines the speed in rpm, that the refrigerated circulator is operated

Cool now:

If you want to perform a cooling immediately, you can select it with this setting.

Stop now:

If you want to stop the cooling immediately, you can select it with this setting.



NOTICE

The "Cleaning" menu item increases the service life of the pump, since solvent residues do not remain inside the pump.

You can also clean the pump without using the corresponding menu item. To do this, remove the hoses and operate the pump at the end of a working cycle (test, test series, end of the day ...) at idling speed.

Start after...:

Specifies after which minimum duration of a measurement the cleaning should take place. The default time is 5 minutes. This means that a measurement must be run for at least 5 minutes, so that cleaning is performed at the end of the measurement.

Duration:

Specifies how long the cleaning process should be performed.

Pump speed:

Determines at what power (in %) the pump is operated during cleaning. If the power is set too high this can lead to a pressure drop in the system.

Clean now:

If you want to perform a cleaning, you can select it with this setting.

Limits

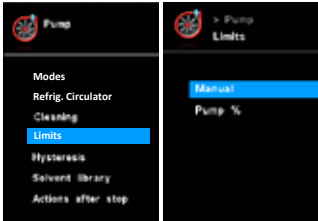

In this menu, limits for the target value can be set.

Hysteresis (VC 10 pro)

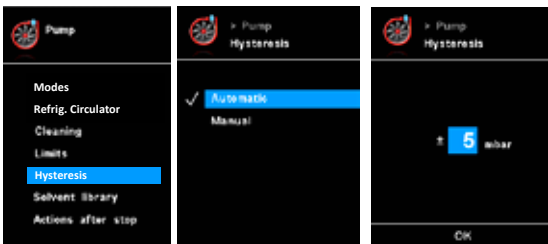

With the “Hysteresis” option, the switching frequency and control accuracy can be influenced when in a steady state. The hysteresis value determines the upper and lower limits of the target value and therefore the closing and opening of the pump and valve (only for two-position control).

Automatic: Hysteresis is always 10 % of the actual pressure.

Manual: Manual value specification of hysteresis.



Limits which are too narrow shorten the service life of the devices.

Solvent Library (VC 10 pro)



In the “solvent library”, the most common solvents are assigned a function to determine the steam temperature at the set pressure and vice versa. This provides assistance when setting these parameters in manual mode, for example, evaporation processes with a rotary evaporator.

Actions after stop

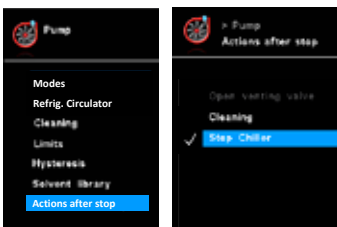

This menu allows the user to define actions that should be performed when a test has ended.

Actions after start

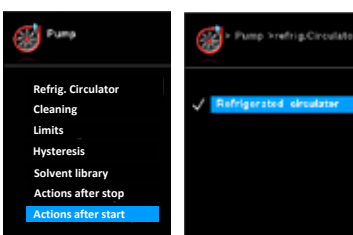

This menu allows the user to define actions that should be performed when a test has started.

Leakage test

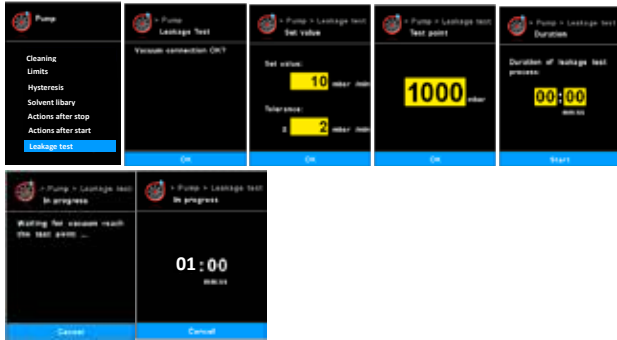

Leakage test: User to confirm the vacuum connection. Press ok if the connection is good.

Set Value: User to input the required leakage rate with tolerance. Default leakage rate is 3mbar with tolerance 1mbar.

Test point: User to input the pressure which the leakage test will

be executed at. Default value is 500 mbar.

Duration: User to input duration of the leakage test. Default value is 1 minute.

In progress: The pump will start running to reach the test point. (Graph below: Phase 1 and 2)

The leakage measurement will start once the pressure has reached the interested test point. Meanwhile, the timer will start counting down from the pre-set duration. (Graph below: Phase 3)

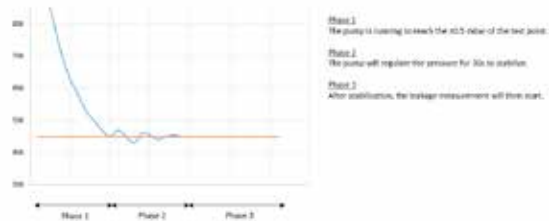

Temperature (VC 10 pro)

Temperature sensor



In the "Temperature" menu the user can specify that the temperature sensor is displayed on the display/working screen. A tick (✓) shows that the option is activated.

The precondition for this is that a temperature sensor is connected to the vacuum controller. If no temperature sensor is connected, or an error is present or the temperature rises above 350 °C, three dashes are shown as the temperature value.



Please comply with the temperature measurement range of the external temperature sensor specified in the "Technical data" section. The temperature display can be in either °C or °F (see the "Settings" menu).

Calibration

In order to calibrate the external temperature sensor, it must first be connected to the vacuum controller. The temperature sensor is then immersed in a vessel with water, for example. The water temperature is determined using a second, already calibrated temperature measuring device. The measured temperature must then be entered in the menu under "Temperature calibration". Once the entry has been confirmed with "OK", the external temperature sensor is calibrated.

Timer

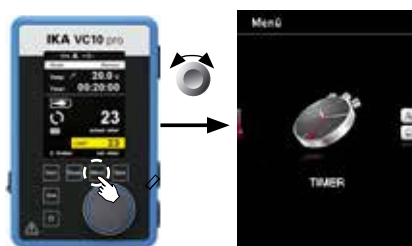

Timer functions

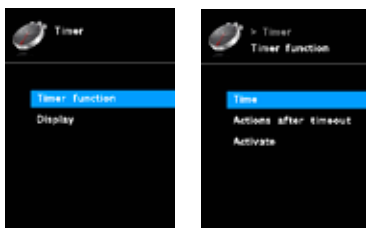

In the "Timer" menu the user can specify that the timer is displayed on the display/working screen. A tick (✓) shows that the

option is activated. This setting allows the user to specify the actual time for the evacuation procedure.

A default time can also be set for the timer. This setting allows the user to start evacuation for a standard time. The device can emit a signal (beep) after the set target time has elapsed.



The user can stop the evacuation procedure before expiry of the set time. In this case the countdown of the timer is interrupted.

Operating mode



Operating mode A:

In this operating mode, the set target value is not saved when the current run comes to an end or the device is switched off.

Operating mode B:

In this operating mode, the set target value is saved when the

current run comes to an end or the device is switched off, and the value can be changed.

Operating mode C:

In this operating mode, the set target value is saved when the current run comes to an end or the device is switched off, and the value cannot be changed.

Operating mode D:

In this operating mode, the target value is applied if it does not change after 3 seconds, or when the yellow background is displayed behind the target value. In operating modes A and B, the target value is applied immediately when the target value is changed by turning the knob.

In operating mode C, the target value cannot be changed.

Display

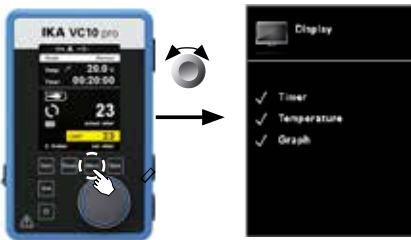

In the "Display" menu the user can specify what information will be displayed on the main screen.

Graph



In the "Graph" menu, user can observe the real-time pressure change on the shown graph.

Programs

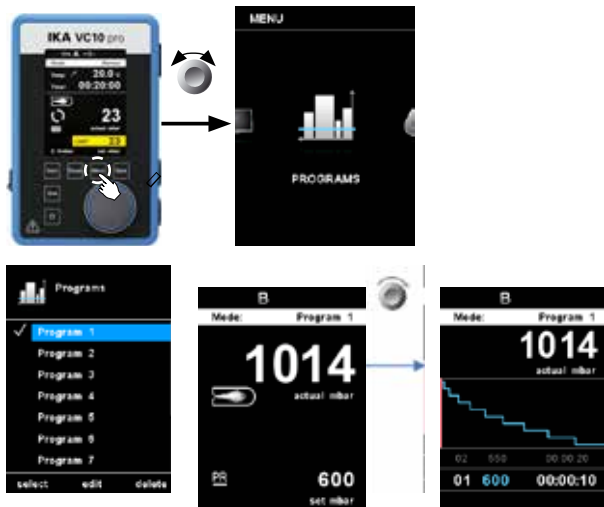

Select:

To select a program, use the rotating/pressing knob and press "Select". Only programs that have at least one program segment can be selected.

When a program has been successfully selected, this is indicated by a tick mark (✓). The vacuum controller is then in program mode. In the main screen, the program view can then be selected by turning the knob to the right. Turning the knob to the left returns the user to the main screen.

Start:

To start a selected program, the push knob must be pressed in the main screen.

Edit:

Edit the selected program parameters. Start to edit the selected program parameters by pressing on menu option "Edit" with rotating/pressing knob. The user can edit, delete or insert one selected program segment in the program.

Delete:

Deletes the selected program. If a selected program is deleted by pressing on menu option "Delete" with rotating/pressing knob, all the program parameters will be emptied. The tick (✓) disappears.

Details for editing the program

Program 1		
No.	Pressure	hh:mm:ss
01	600 mbar	00:00:10
02	550 mbar	00:00:20
03	500 mbar	00:00:30
04	450 mbar	00:00:40
05	400 mbar	00:00:50
06	350 mbar	00:01:00
07	300 mbar	00:01:10
08	250 mbar	00:01:20
edit insert delete		

When a program is being edited, following screen appears.

In this program, user can define up to 10 segments. The selected segment is highlighted. Then, the user can edit, delete or insert a segment in this program. The program is save automatically.

Edit:

If the background of a selected value is yellow, the user can change the setting of the pressure value or the time value.

Delete:

When a highlighted segment is deleted, the subsequent segments move upward, closing the gap created by the deleted segment.

Sample for editing the program

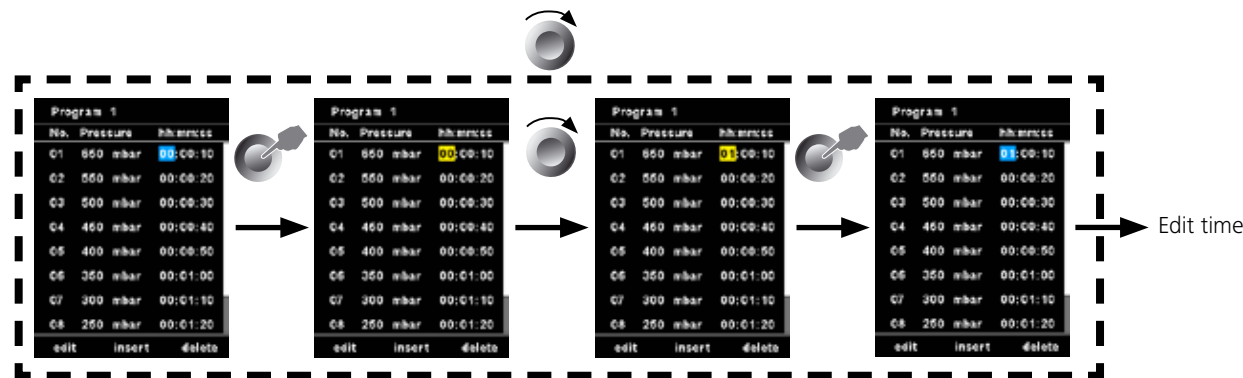
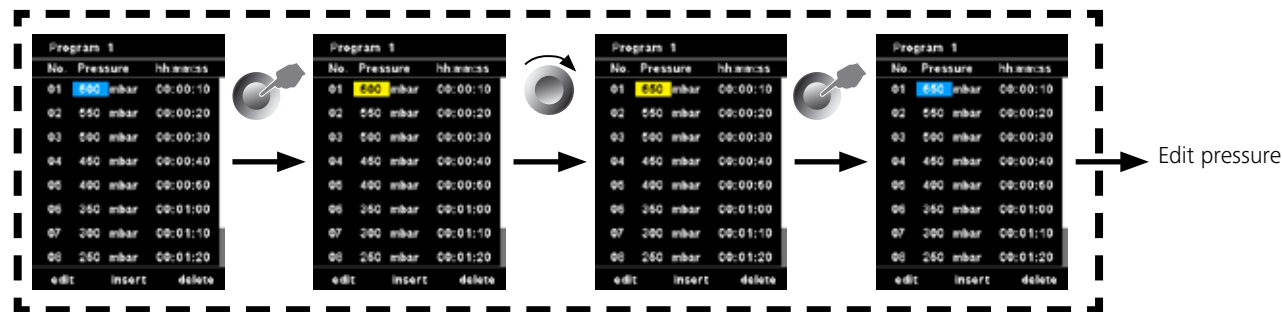
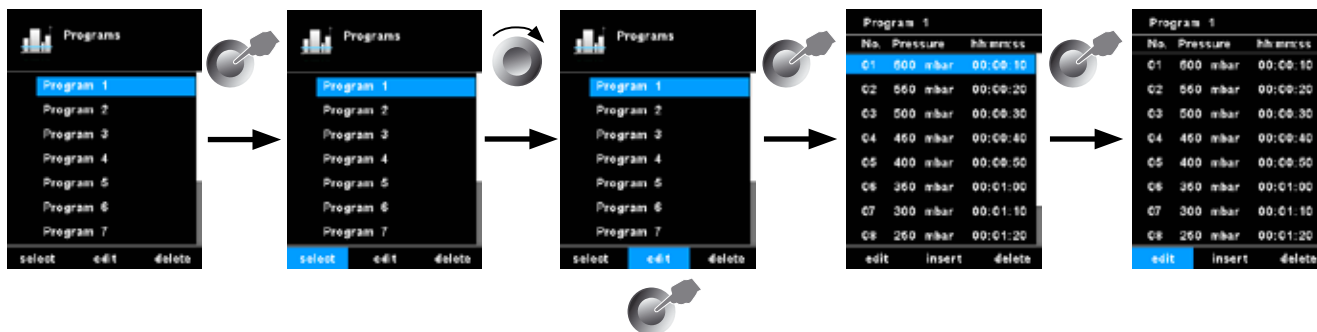

Example of saving the last measurement

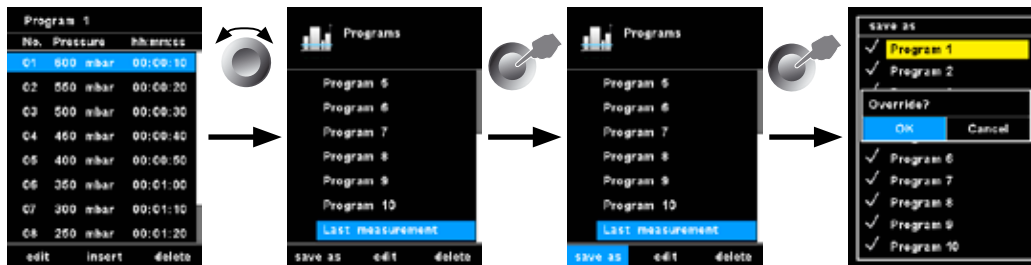

Safety

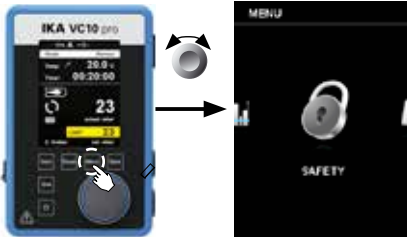

In the "Password" menu, the user can protect the vacuum controller settings using a password.
(factory setting: 000)

Service



In the "Service" menu, the valves, the pump or the refrigerated circulator can be operated individually and also checked to ensure that they are operating correctly. If no VACSTAR is connected, the menu item "Pump" is greyed out and not active.

Settings



Languages:

The "Languages" option allows the user to select the desired language by turning and pressing the rotating/pressing knob (D). A tick (✓) indicates the language that is set for the system.

Units:

The "Units" option allows the user to select the desired unit for displaying the temperature and pressure by turning and pressing the rotating/pressing knob. For the temperature, the choice is between "°C" or "°F". For the pressure, the choice is "mbar", "hPa", "mmHg" or "Torr". A tick (✓) indicates the unit that is set for the system.

Display:

The "Display" option allows the user to change the background color and brightness of the working screen.

Sound:

The "Sound" option allows the user to activate/deactivate the key-press sound and to set the volume.

Factory settings:

Select the "Factory settings" option by turning and pressing the rotating/pressing knob. The system requests confirmation to re-create the factory settings. You can choose if you want to reset only the "Menu values", or only the "Programs". Alternatively, you can reset all by selecting "All". Pressing the "OK" key resets the system settings to the original standard values set at dispatch from the factory (see "Menu structure" illustration).

Communication:

The "Device name" option allows the user to input a device name. The device name appears on the opening screen when the device is switched on.

This can be useful when using multiple devices with different settings. This also facilitates the identification of each device when communicating with a PC via USB, RS232 and Bluetooth, for example.

Information:

The "Information" option offers the user an overview of the most important system settings of the vacuum controller VC 10 lite/pro.

Interfaces and outputs

The device can be operated in "Remote" mode via an RS 232 or USB interface using the laboratory software *labworldsoft*[®].

The RS 232 interface at the back of the device is fitted with a 9-pole SUB-D port which can be connected to a PC. The pins are assigned serial signals.



NOTICE

Please comply with the system requirements together with the operating instructions and help section included with the software.

USB interface

The Universal Serial Bus (USB) is a serial bus for connecting the device to the PC. Equipped with USB devices can be connected to a PC during operation (hot plugging). Connected devices and their properties are automatically recognized.

Use the USB interface in conjunction with *labworldsoft*[®] for operation in "Remote" mode and also to update the firmware.

Installation

First, download the latest driver for devices with USB in-terface from <http://www.com/lws/download/usb-driver.zip> and install the driver by running the setup file. Then connect the device through the USB data cable to the PC.

Serial interface RS 232 (V 24)

Configuration:

- The functions of the interface connections between the device and the automation system are chosen from the signals specified in EIA standard RS 232 in accordance with DIN 66 020 Part 1.
- For the electrical characteristics of the interface and the allocation of signal status, standard RS 232 applies in accordance with DIN 66 259 Part 1.
- Transmission procedure: asynchronous character transmission in start-stop mode.
- Type of transmission: full duplex.
- Character format: character representation in accordance with data format in DIN 66 022 for start-stop mode. 1 start bit; 7 character bits; 1 parity bit (even); 1 stop bit.
- Transmission speed: 9600 bit/s
- Data flow control: none
- Access procedure: data transfer from the device to the computer takes place only at the computer's request

Command syntax and format

The following applies to the command set:

- Commands are generally sent from the computer (Master) to the stirrer machine (Slave).
- The stirrer machine sends only at the computer's request. Even fault indications cannot be sent spontaneously from the device to the computer (automation system).
- Commands are transmitted in capital letters.
- Commands and parameters including successive parameters are separated by at least one space (Code: hex 0x20).
- Each individual command (incl. parameters and data) and each response are terminated with Blank CR LF (Code: hex 0x20 hex 0x0d hex 0x20 hex 0x0A) and have a maximum length of 50 characters.
- The decimal separator in a number is a dot (Code: hex 0x2E).

The above details correspond as far as possible to the recommendations of the NAMUR working party (NAMUR recommendations for the design of electrical plug connections for analogue and digital signal transmission on individual items of laboratory control equipment, rev. 1.1).

The NAMUR commands and the additional specific commands serve only as low level commands for communication between the stirrer machine and the PC. With a suitable terminal or communications programme these commands can be transmitted directly to the stirrer equipment.

The software package, *labworldsoft*[®], provides a convenient tool for controlling the equipment and collecting data under MS Windows, and includes graphical entry features, for motor speed ramps for example.

The following table summarises the (NAMUR) commands understood by the control equipment.

NAMUR Commands	Function
IN_NAME	Read device name
IN_PV_3	Read PT 1000 value
IN_PV_66	Read current pressure value
IN_SP_66	Read pressure target value
IN_SP_70	Read hysteresis target value
IN_MODE_66	Read current evacuation mode
IN_ERROR	Read error status
OUT_SP_66	Set pressure target value
OUT_SP_70	Set hysteresis value
OUT_MODE_66	Set evacuation mode
START_66	Start evacuation
STOP_66	Stop evacuation
RESET	Switch to normal operating mode

PC 1.1 Cable (Device to PC)

Required for connecting the 9-pin socket to a PC.

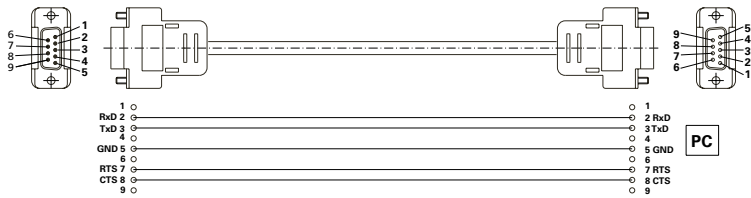

Fig. 10

Connection VC 10 lite/pro - PC

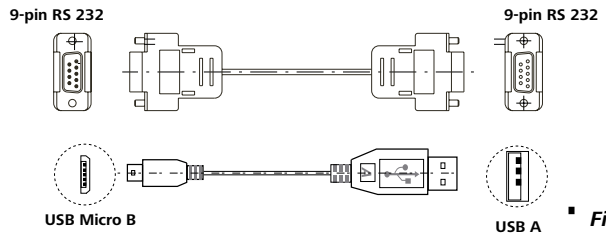
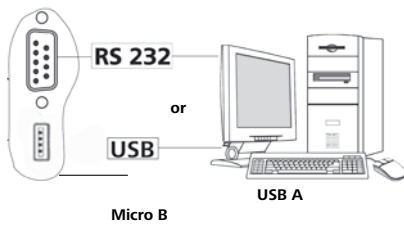
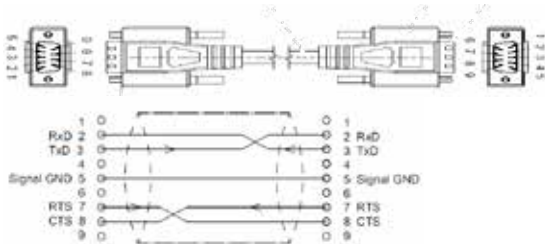

Fig. 11

Connection Refrigerated circulator

PC1.3 Cable (Device - Refrigerated circulator)



Connection (Device - Refrigerated circulator)

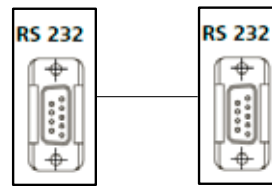

Connection cable

This cable is required to connect the VC 10 lite/pro to the VACSTAR (speed mode).



Fig. 12

Maintenance and cleaning

The device is maintenance-free. It is only subject to the natural wear and tear of components and their statistical failure rate.

Cleaning

- For cleaning disconnect the mains plug!
- Use only cleaning agents which have been approved by to clean devices.
These are water (with tenside) and isopropanol.
- Wear protective gloves during cleaning the devices.
- Electrical devices may not be placed in the cleansing agent for the purpose of cleaning.
- Do not allow moisture to get into the device when cleaning.
- Before using another than the recommended method for cleaning or decontamination, the user must ascertain with that this method does not destroy the device.

Spare parts order

When ordering spare parts, please give:

- device type.
- serial number, see type plate.
- position number and description of spare part, see www.ika.com.
- software version

Repair

Please only send devices in for repair that have been cleaned and are free of materials which might present health hazards.

For repair, please request the "Safety Declaration (Decontamination Certificate)" from or use the download printout of it from website at www.ika.com.

If your appliance requires repair, return it in its original packaging. Storage packaging is not sufficient when sending the device - also use appropriate transport packaging.

Error codes

Error:

The fault is shown by an error message in the display as following if the error occurs, e.g. Error 4.
Proceed as follows in such cases:

- Switch the device switch off,
 - carry out corrective measures,
 - switch the device switch on again.
- ⇒ Measurement is stopped.

Warning:

- Measurement is stopped.
- Warning is displayed.
- Warning can be confirmed.

Information:

- Measurement continues.
- Information is displayed.
- Information can be confirmed.

Description	Detection	Reason	Action
Information No Pressure Change	Pressure gradient analysis does not show any deviation.	Pump is not running. Vacuum hose isn't connected. Failure in hose system. Recipient isn't closed.	Check pump control cable connection. Check pump power supply. Switch on pump. the position. Check correct vacuum hose connection (IN/ OUT/VENT). Close recipient.
Information System Not Tight	Pressure gradient analysis shows pressure deviation, but set value cannot be reached.	Vacuum hose connection isn't tight. Recipient isn't tight. Vacuum pump power isn't sufficient. Venting valve leakage. Boiling point of solvent is reached before.	Check vacuum hose connection. Check recipient. Check technical data of the pump. Call service department. Check set value.
Information Venting Error	Pressure gradient analysis does not show any deviation after pressing the "Venting" button.	Recipient wasn't evacuated at all. Failure in hose system. Venting valve leakage. Front foil button is damaged.	Evacuated recipient. Check correct vacuum hose connection (IN/ OUT/VENT). Call service department.
Pump not connected	Connection to Vacstar(speed mode) not present.	Damaged or no cable connected	Check connection cable is present and well connected.
Warning Boiling Point Error	Boiling point cannot be detected. Pressure gradient analysis does not show boiling point.	Heating bath does not heat up. Solvent with extreme low boiling point is used.	Check heating bath. Solvent distillation only manually.
Warning External Temperature Is Too High	Measured temperature is too high. External temperature is higher than maximum value	Medium temperature is too high. External sensor is broken.	Check the medium temperature. Call service department.
Warning External Temperature Is Too Low	Measured temperature is too low. External temperature is lower than minimum value.	Medium temperature is too low. External sensor is short-connected.	Check the medium temperature. Call service department.
Warning Control Pump State Error	Pump is disconnected during analog speed control mode. Pump is connected during 2-point control mode.	Pump is disconnected during analog speed control mode. Pump is connected during 2-point control mode	Connect the pump. Disconnect the analog pump.
Warning RS232 Communication Error USB Communication Error	Watchdog time elapsed.	labworldsoft® uses wrong device for VC 10 lite/pro. Wrong tools are used to communicate with VC 10 lite/pro. Unstable connection. Watchdog was set in device or via PC command.	Check the labworldsoft® setting. Check the PC tools. Check the connection. Disable watchdog when not necessary. Increase sample rate.

Description	Detection	Reason	Action
Warning Temperature Calibration Error	Temperature calibration value is out of range.	Wrong simulator resistance is chosen. Set wrong temperature calibration value.	Check the simulator resistance. Call service department.
Warning Pressure Calibration Error	Pressure calibration value is out of range.	Input wrong vacuum actual value when calibration. Set wrong vacuum calibration value. Sensor is broken.	Calibrate again. Check the set calibration value. Call service department.
Error 3 Device Temperature Error.	Analysis of internal PCB temp. Sensor. Inside temperature reaches limit value.	Room temperature > 40 °C. PCB or valve is broken.	Switch off device for cool down. Call service department.
Error 9 Logic Storage Error. Display Storage Error.	Read or write internal memory error.	Read or write internal memory error.	Call service department.
Error 68 Pressure Out Of Range.	Pressure is out of range. Pressure is bigger than room pressure.	Pressure in the recipient is too high. Sensor is broken.	Check the air flow of pump and vent recipient. Call service department.
Error 69 Pressure Sensor Error.	Pressure sensor output is too low.	Sensor is not connected. Sensor is broken.	Check the sensor connection. Call service department.
Error 71 Internal Communication Error	Internal Watchdog elapsed.	Communication lost between logic board and display board.	Restart device (unplug mains cable, plug in mains cable). Check communication between logic board and display board. Call service department.

If the actions described fails to resolve the fault or another error code is displayed then take one of the following steps:

- contact the service department,
- send the instrument for repair, including a short description of the fault.

Accessories

Accessories see www.ika.com.

Product contact parts

Designation	Material
Connection spigots	PP
Distributor	PPS
Pressure sensor	FPM/AL2O3
Vacuum valve	PEEK; EPDM; FKM
Venting valve	PEEK; EPDM; FKM

Technical data

	Unit	VC 10 lite	VC 10 pro
Connection diameter suction side	mm	8	
Connection diameter pressure side	mm	8	
Connection diameter venting side	mm	8	
Input pressure min.	mbar	1	
Input pressure max.	mbar	1050	
Boiling point detection		-	yes
Solvent library			yes
Two-point control		-	yes
Analog speed vacuum control			yes
Display			TFT
Pressure unit / scale			mbar, hPa, mmHg, Torr
Vacuum sensor			yes
Vacuum sensor type			ceramic Al ₂ O ₃
Pressure max. for pressure sensor	bar	1.6	
Measurement range (absolute) min.	mbar	1	
Measurement range (absolute) max.	mbar	1100	
Control range min.	mbar	1	
Control range max.	mbar	1100	
Resolution pressure	mbar	1	
Measurement uncertainty	mbar	1	
Medium temperature (gas) min.	°C	5	
Medium temperature (gas) max.	°C	40	
Vacuum valve		-	yes
Venting valve			yes
Connection for ext. temperature sensor		-	PT 1000
Temperature unit		-	°C/°F
Temperature measuring range min.	°C	-	-10
Temperature measuring range max.	°C	-	200
Temperature measurement resolution	K	-	1
Accuracy of temperature measurement	K	-	±1
Timer			yes
Time setting min.	s	1	
Time setting max.	min	6000	
Vacuum speed control interface			VACSTAR
Material in contact with medium			Al ₂ O ₃ , PTFE, FPM, PPS
Housing material			PBT
Fastening			stand/clamp
Fastening diameter	mm	16	

	Unit	VC 10 lite	VC 10 pro
Dimensions (B x H x T)	mm	95 x 150 x 110	
Weight	kg	1.5	
Permissible ambient temperature min.	°C	5	
Permissible ambient temperature max.	°C	40	
Permissible relative humidity	%	80	
Protection class according to DIN EN 60529		IP 20	
RS 232 interface		yes	
USB interface		yes	
Voltage	V	100 - 240	
Frequency	Hz	50/60	
Power input	W	24	
Power input standby	W	2	
DC Voltage	V	24	
Current consumption	mA	1000	

Subject to technical changes!