

IKA

designed for scientists

IKA Rocker 2D digital



IKA Rocker 2D basic



Indicaciones de seguridad	ES	43
Veiligheidsinstructies	NL	43
Norme di sicurezza	IT	44
Säkerhetsanvisningar	SV	45
Sikkerhedshenvisninger	DA	46
Sikkerhedsanvisninger	NO	46
Turvallisuusohjeet	FI	47
Normas de segurança	PT	48
Υποδείξεις ασφαλείας	EL	49

Betriebsanleitung	DE	3
Operating instructions	EN	11
Mode d'emploi	FR	19
Инструкция по эксплуатации	RU	27
使用说明	ZH	35

Wskazówki bezpieczeństwa	PL	49
Bezpečnostní upozornění	CS	50
Biztonsági utasítások	HU	51
Varnostna navodila	SL	52
Bezpečnostné pokyny	SK	52
Ohutusjuhised	ET	53
Drošības Norādes	LV	54
Saugos Reikalavimai	LT	55
Инструкции за безопасност	BG	55
Indicații de siguranță	RO	56

Contents

	Page
Declaration of conformity	11
Explication of warning symbols	11
Warranty	11
Safety instructions	12
Unpacking	12
Correct use	13
Commissioning	13
Accessories	16
Maintenance and cleaning	16
Error codes	17
Technical data	18

Declaration of conformity

We declare under our sole responsibility that this product corresponds to the regulations 2006/42/EC, 2011/65/EU, 2014/30/EU and 2014/35/EU and conforms with the standards or standardized documents: EN 61010-1, EN 61010-2-051, EN 61326-1, EN 60529 (A1+A2) and EN ISO 12100.

A copy of the complete EU Declaration of Conformity can be requested at sales@ika.com.

Explication of warning symbols



General hazard



Indicates crushing risk of fingers/hand.

Warranty

In accordance with **IKA** warranty conditions, the warranty period is 24 months. For claims under the warranty please contact your local dealer. You may also send the machine direct to our factory, enclosing the delivery invoice and giving reasons for the claim. You will be liable for freight costs.

The warranty does not cover worn out parts, nor does it apply to faults resulting from improper use, insufficient care or maintenance not carried out in accordance with the instructions in this operating manual.

Safety instructions

For your protection



Read the operating instructions in full before starting up and follow the safety instructions.

- Keep the operating instructions in a place where they can be accessed by everyone.
- Ensure that only trained staff work with the appliance.
- Follow the safety instructions, guidelines, occupational health and safety and accident prevention regulations.
- Wear your personal protective equipment in accordance with the hazard category of the medium to be processed. Otherwise there is a risk of:
 - splashing liquids
 - projectile parts
 - body parts, hair, clothing and jewellery getting caught.
- Set up the device in a spacious area on an even, stable, clean, non-slip, dry and fireproof surface.
- The feet of the appliance must be clean and undamaged.
- Check the appliance and accessories beforehand for damage each time you use them. Do not use damaged components.



Caution!

There is a crush hazard between the moving shaking table and the casing.

- Place the vessels securely on the shaking table or on the chosen mat or rack.
- Firmly secure the accessories and vessels in place, otherwise shaking vessels could be damaged or projected out.
- Position one single shaking vessel in the centre and several shaking vessels so that they are evenly spread out.
- Always load the samples evenly on the device.
- The weight of the load must not exceed 2 kg. Do not exceed the maximum permissible shaking weights.
- Do not move or transport the device when it is operating or connected to the power supply.
- Reduce the speed if
 - the medium splashes out of the vessel because the speed is too high
 - the appliance is not running smoothly
 - dynamic forces start to cause the device and/or the vessels placed on it to move around.

- The appliance is not suitable for manual operation.
- Beware of the risk of
 - flammable materials
 - glass breakage as a result of mechanical shaking power
- The appliance may heat up when in use.
- Only process media that will not react dangerously to the extra energy produced through processing. This also applies to any extra energy produced in other ways, e.g. through light irradiation.
- Process pathogenic materials only in closed vessels under a suitable extractor hood. Please contact **IKA** if you have any questions.
- Do **not** operate the appliance in explosive atmospheres, with hazardous substances or under water.
- Safe operation is only guaranteed with the accessories described in the "Accessories" chapter.
- Always disconnect the plug before fitting accessories.
- Disconnect the device from the power supply before you open the cover or adjust the inclination angle of the device shaking table.
- Do not operate the device with the cover open.
- The appliance can only be disconnected from the mains supply by pulling out the mains plug or the connector plug.
- The socket for the mains cord must be easily accessible.
- The **IKA Rocker 2D basic** does not restart automatically when power is restored after a power outage. If the **IKA Rocker 2D digital** is running in mode A it does not restart automatically when power is restored after a power outage.

For protection of the equipment

- The appliance may only be opened by experts.
- The voltage stated on the type plate must correspond to the mains voltage.
- Removable parts must be refitted to the appliance to prevent the infiltration of foreign objects, liquids etc..
- Protect the appliance and accessories from bumps and impacts.
- The device must only be operated with the original plug-in power supply unit.

Unpacking

Unpacking

- Please unpack the device carefully.
- In the case of any damage a detailed report must be sent immediately (post, rail or forwarder).

Delivery scope

- **IKA Rocker 2D basic/digital**, depending on the type that was ordered
- Mat
- AC adapter, see Fig. 1
- Operating instructions
- Warranty card



Fig. 1

Correct use

Use

For mixing and agitating liquids.

IKA Rocker 2D basic

- Continuous operation for individual or multiple vessels.

IKA Rocker 2D digital

- Continuous operation for individual or multiple vessels.
- Timer operation for individual or multiple vessels.

Range of use

Indoor environments similar to that a laboratory of research, teaching, trade or industry.

The safety of the user cannot be guaranteed:

- If the device is operated with accessories that are not supplied or recommended by IKA.
- If the device is operated improperly or in contrary to the IKA specifications.
- If the device or the printed circuit board are modified by third parties.

Commissioning

- Check that the power supply matches the data on the rating plate.
 - Plug the AC adapter into a standard mains socket in order to supply the device with power. See the section "Technical data" for the connection values.
 - Also pay attention to the ambient conditions listed in the "Technical data".
- The **IKA Rocker 2D basic** does not restart automatically when power is restored after a power outage. If the **IKA Rocker 2D digital** is running in mode A it does not restart automatically when power is restored after a power outage.

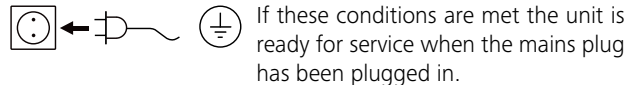

IKA Rocker 2D basic

The AC adapter is suitable for 100 V upto 240 V. Insert an appropriate adapter corresponding to the country, before plugging the AC adapter into the mains socket.



Switching the device on

Press the "Power" button (**L**) to switch the device on.



Speed setting

Use the "Speed setting" button (**K**) to set the speed to a value between 5 and 80 rpm in units of 1 rpm.



Starting the device

Press the "Start/Stop" button (**F**) to start the shaking process.



Stopping the device

Press the "Start/Stop" button (**F**) to stop the shaking process.



Switching off the device

Press the "Power" button (**L**) to switch the device off.



IKA Rocker 2D digital

The AC adapter is suitable for 100 V upto 240 V. Insert an appropriate adapter corresponding to the country, before plugging the AC adapter into the mains socket.



Switching the device on

Press the "Power" button **(L)** to switch the device on.



The following data appear on the display in the sequence listed:

- the test image
- the software version
- the operating mode
- the values and settings last used



Speed setting

Use the "Speed setting" button **(K)** to set the speed to a value between 5 and 80 rpm in units of 1 rpm.



Timer/Counter

Select "Counter" or "Timer" **(I)**.

Timer

When "Timer" is selected, the set value counts down. Once the timed shaking cycle has been completed the device switches off automatically.

→ An acoustic signal beeps three times and the "Timer" LED **(H)** flashes red.



Counter

The counter measures the time from the start of shaking to the end.

→ The "Counter" LED **(G)** flashes red.

If the "Start/Stop" button **(F)** is pressed the shaking process stops and the elapsed time is displayed. If the counter is restarted the measurement restarts afresh.



To switch from counter to timer or vice versa, press the "Timer" button **(I)**.

Setting

Set the timer from 1 sec to 99 h 59 min using the "Plus/Minus" timer setting buttons **(J)**.

Press the "Start/Stop" button **(F)** to start the shaker.

The last timer value setting is saved and is loaded for the next shaking process.

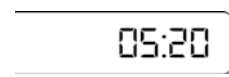

Resetting to 0

To reset the timer, press the "Timer Minus" and "Timer Plus" buttons **(J)** simultaneously.



Starting the device

Press the "Start/Stop" button **(F)** to start the shaking process.

The device starts with the desired settings.



Stopping the device

Press the "Start/Stop" button **(F)** to pause operation.



Switching off the device

Press the "Power" button **(L)** to switch the device off.



Operating modes A and B

Operating mode A

The device does not restart automatically when power is restored after a power outage.

Operating mode B

The device restarts automatically when power is restored after a power outage, using the set values, and displays the (Pr) symbol to indicate that there has been a power outage within a certain period of time.

Adjusting the inclination angle of the shaking table

The inclination angle of the shaking table can be adjusted in steps of 2.5° from 2.5 - 15°.



Caution! Do not remove the cover (2) whilst the device is in operation!

Stop the device by pressing the "Start/Stop" button (F). Do not use your hand to stop the device.

Press the "Power" button (L) to switch the device off.

Switching between operating modes

To switch between operating modes, switch the device off, then keep the "Start/Stop" button (F) depressed and press the "Power" button (L).

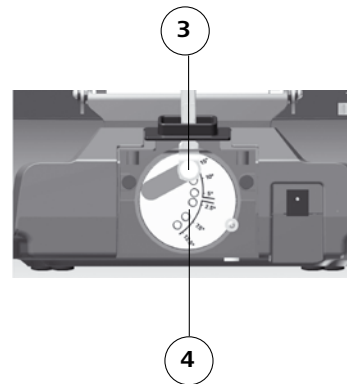





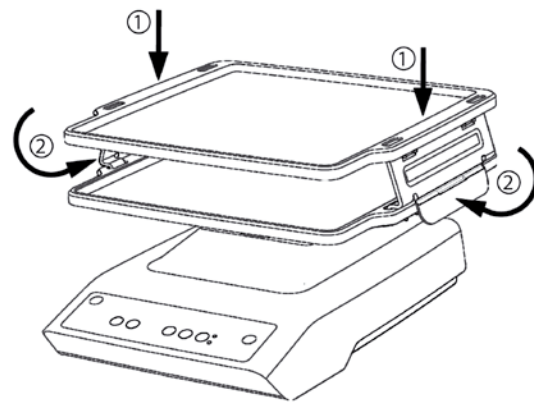
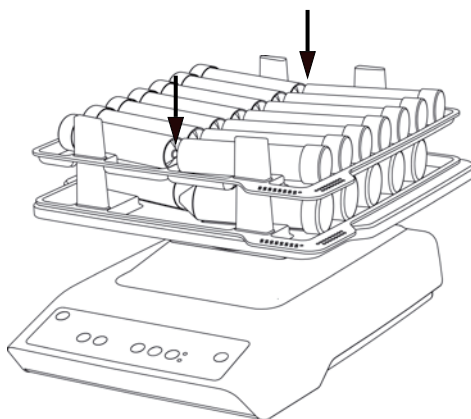

- Undo the screws (1) to remove the cover (2) at the rear of the device.
- Slacken the screw (3) and select the desired inclination angle (4). Tighten the screw (3) finger tight.
- Refit the cover (2) and secure it with the screws (1).

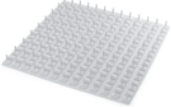
Use of accessories



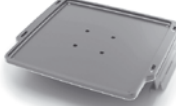

Accessories

	Designation	Max number	Description	Number of tubes per rack max.
	Mat RD 1	-	Base for vessels with a flat bottom, e.g. Petri dishes, cell culture flasks	-
	Spiked mat RD 2	-	Base for test tubes up to \varnothing 30 mm, e.g. Eppendorf tubes, Greiner-tubes	Example of possible placement 
	Rack TB 1	5	For 28 test tubes 5 ml, \varnothing 12 mm	28 x 5 ml \varnothing 12 mm tubes
	Rack TB 2	4	For 12 test tubes 15 ml, \varnothing 16 mm	12 x 15 ml \varnothing 16 mm tubes
	Rack TB 3	4	For 10 test tubes 30 ml, \varnothing 25 mm	10 x 30 ml \varnothing 25 mm tubes
	Rack TB 4	4	For 6 test tubes 50 ml, \varnothing 28 mm	6 x 50 ml \varnothing 28 mm tubes
	Stacking table A 2	1	-	-

Maintenance and cleaning

The device operates maintenance-free.

   For cleaning disconnect the main plug.

Only clean **IKA** appliances using these **IKA** approved cleaning agents: water containing surfactant / isopropyl alcohol.

- Wear protective gloves when cleaning the devices.
- Do not place electrical appliances into the cleaning agents for cleaning purposes.
- Do not allow moisture to get into the appliance when cleaning.
- Please consult with **IKA** before using any cleaning or decontamination methods, other than those recommended here.

Spare parts order

When ordering spare parts, please give:

- Machine type
- Manufacturing number, see type plate
- Item and designation of the spare part, see www.ika.com, spare parts diagram and spare parts list

Repair

In case of repair the device has to be cleaned and free from any materials which may constitute a health hazard.

For this you should use the downloaded print of the "**Certificate of compliance**" form from the **IKA** website www.ika.com.

If you require servicing, return the appliance in its original packaging. Storage packaging is not sufficient. Please also use suitable transport packaging.

Error codes

IKA Rocker 2D basic

In case of a fault, a beep is heard and the "Power" LED flashes.

Proceed as follows in such cases:

1. Switch the device off.
2. Perform corrective measures as described below.
3. Perform a restart.

Error	Cause	Effect	Solution
	Motor blockage or overload	Motor off	<ul style="list-style-type: none">• Switch the device off.• Reduce the load on the motor and check all moving parts for freedom of movement.• Then perform a restart.

If the actions described fail to resolve the fault or another error code is displayed then take one of the following steps:

- Contact the **IKA** service department,
- Send the device for repair, including a short description of the fault.

IKA Rocker 2D digital

The fault is shown by an error code in the display as following if the error occurs, e.g. Er 4.

Proceed as follows in such cases:

1. Switch the device off.
2. Perform corrective measures as described below.
3. Perform a restart.

Error	Cause	Effect	Solution
Er 3	Temperature inside device is too high	Motor off	<ul style="list-style-type: none">• Switch the device off.• Allow the device to cool down.
Er 4	Motor blockage or overload	Motor off	<ul style="list-style-type: none">• Switch the device off.• Reduce the load on the motor and check all moving parts for freedom of movement.• Then perform a restart.

If the actions described fail to resolve the fault or another error code is displayed then take one of the following steps:

- Contact the **IKA** service department,
- Send the device for repair, including a short description of the fault.

Technical data

Power supply		
Input	V	100 - 240
	A	0.8
	Hz	50-60
Output	VDC	24
		24W.LPS (Limited power source)
Protection class		2 (double insulated) <input type="checkbox"/>

Shaker		IKA Rocker 2D basic	IKA Rocker 2D digital
DC	V	24	
Max. device power consumption	W	24	
Motor power consumption	W	16	
Motor output power	W	9	
Type of movement		rocking	
Permissible shaken weight (incl. fixture)	kg	2	
Inclination angle of the shaking table	°	-	2.5 ... 15
Adjustment inclination angle of the shaking table		-	2.5 ° steps
Fixed inclination angle	°	8	
Speed min.	rpm	5	5
Speed preset definitely	rpm	-	-
Speed max.	rpm	80	80
Speed variation	%	10	5
Adjustment speed		1 rpm steps	
Speed display		7-segment LED	
Timer		-	yes
Timer display		-	7 Segment LED
Operating mode		continuous operation	timer and continuous operation
Adjustment timer min.	sec	-	1
Adjustment timer max.	h:min	-	99 h 59 min
Dimensions (W x D x H)	mm	280 x 330 x 150	280 x 330 x 150
Weight	kg	2.2	2.3
Perm. duration of operation	%	100	
Perm. ambient temperature	°C	+ 4 ... + 50	
Perm. rel. humidity	%	80	
Protection acc. DIN EN 60529		IP 21	
Overvoltage category		II	
Protection class		II	
Contamination level		2	
Shaking table size (W x D)	mm	235 x 235	
Operation at a terrestrial altitude	m	max. 2000 above sea level	

Subject to technical changes!