

IKA

designed for scientists

IKA RV 8



Betriebsanleitung Ursprungssprache	DE	04
Operating instructions	EN	19
Mode d'emploi	FR	34
Руководство пользователя	RU	49
Kezelési útmutató	HU	64
使用说明	ZH	79
取扱説明書	JA	94
사용 설명서	KO	109

Indicaciones de seguridad	ES	124	Bezpečnostní pokyny	CS	142
Veiligheidsinstructies	NL	126	Varnostna opozorila	SL	144
Norme di sicurezza	IT	128	Bezpečnostné pokyny	SK	146
Säkerhetsanvisningar	SV	130	Ohutusjuhised	ET	148
Sikkerhedshenvisninger	DA	132	Drošības norādes	LV	150
Sikkerhedsanvisninger	NO	134	Nurodymai dėl saugumo	LT	152
Turvallisuusohjeet	FI	136	Инструкции за безопасност	BG	154
Normas de segurança	PT	138	Indicații de siguranță	RO	156
Wskazówki bezpieczeństwa	PL	140	Υποδείξεις ασφάλειας	EL	158

Lösemitteltabelle (Auswahl)

Lösemittel	Formel	Druck für Siedepunkt bei 40 °C in mbar (Für HB ca. 60 °C)
Acetic acid	C ₂ H ₄ O ₂	44
Acetone	C ₃ H ₆ O	556
Acetonitrile	C ₂ H ₃ N	226
N-Amyl alcohol	C ₅ H ₁₂ O	11
n-Pentanol	C ₅ H ₁₀ O	11
n-Butanol	C ₄ H ₁₀ O	25
tert. Butanol	C ₄ H ₁₀ O	130
2-Methyl-2-Propanol	C ₄ H ₁₀ O	130
Butylacetate	C ₆ H ₁₂ O ₂	39
Chlorobenzene	C ₆ H ₅ Cl	36
Chloroform	CHCl ₃	474
Cyclohexane	C ₆ H ₁₂	235
Dichloromethane	CH ₂ Cl ₂	atm. press.
Methylenechloride	CH ₂ Cl ₂	atm. Press.
Diethylether	C ₄ H ₁₀ O	atm. press.
1,2,-Dichloroethylene (trans)	C ₂ H ₂ Cl ₂	751
Diisopropylether	C ₆ H ₁₄ O	375
Dioxane	C ₄ H ₈ O ₂	107
Dimethylformamide (DMF)	C ₃ H ₇ NO	11
Ethanol	C ₂ H ₆ O	175
Ethylacetate	C ₄ H ₈ O ₂	240
Ethylmethylketone	C ₄ H ₈ O	243
Heptane	C ₇ H ₁₆	120
Hexane	C ₆ H ₁₄	335
Isopropylalcohol	C ₃ H ₈ O	137
Isoamylalcohol	C ₅ H ₁₂ O	14
3-Methyl-1-Butanol	C ₅ H ₁₂ O	14
Methanol	CH ₄ O	337
Pentane	C ₅ H ₁₂	atm. press.
n-Propylalcohol	C ₃ H ₈ O	67
Pentachloroethane	C ₂ HCl ₅	13
1, 1, 2, 2, -Tetrachloroethane	C ₂ H ₂ Cl ₄	35
1, 1, 1, -Trichloroethane	C ₂ H ₃ Cl ₃	300
Tetrachloroethylene	C ₂ Cl ₄	53
Tetrachloromethane	CCl ₄	271
Tetrahydrofurane (THF)	C ₄ H ₈ O	357
Toluene	C ₇ H ₈	77
Trichloroethylene	C ₂ HCl ₃	183
Water	H ₂ O	72
Xylene	C ₈ H ₁₀	25

Gewährleistung

Entsprechend den **IKA** - Verkaufs- und Lieferbedingungen beträgt die Gewährleistungszeit 24 Monate. Im Gewährleistungsfall wenden Sie sich bitte an Ihren Fachhändler. Sie können aber auch das Gerät unter Beifügung der Lieferrechnung und Nennung der Reklamationsgründe direkt an unser Werk senden. Frachtkosten gehen zu Ihren Lasten.

Die Gewährleistung erstreckt sich nicht auf Verschleißteile und gilt nicht für Fehler, die auf unsachgemäße Handhabung und unzureichende Pflege und Wartung, entgegen den Anweisungen in dieser Betriebsanleitung, zurückzuführen sind.

Source language: German

EN

Contents

	Page		
Declaration of conformity	19	Commissioning	29
Explication of warning symbols	19	Assembling the stand pillar RV 8.1	30
Safety instructions	19	Maintenance and cleaning	31
Correct use	23	Accessories	31
Unpacking	23	Error Codes	31
Useful information	24	Technical data	32
Installation	24	Solvent table (excerpt)	33
Drive RV 8		Warranty	33
Glassware			
Hose system			
Heating bath			

Declaration of conformity

We declare under our sole responsibility that this product corresponds to the regulations 2014/35/EU, 2006/42/EC, 2014/30/EU and 2011/65/EU and conforms with the standards or standardized documents EN 61010-1, EN 61010-2-051, EN 61326-1, EN 60529 and EN 12100.

A copy of the complete EU Declaration of Conformity can be requested at sales@ika.com.

Explication of warning symbols



General hazard.



This symbol identifies information **that is of vital importance for protecting your health and safety**. Disregarding this information may lead to health impairment and injuries.



This symbol identifies information **that is of vital importance for the technically correct functioning of the system**.

Disregarding this information may result in damage to the instrument or to system components.



This symbol indicates information **which is important for proper use and ensuring that the operations of the instrument are performed efficiently**.

Failure to observe this information may result in inaccurate results.



Danger - Reference to exposure to a hot surface!

Safety instructions

For your protection



The safety lift operates at power failure and when the device is switched off. It is designed to raise itself with the glassware attached. Therefore, please note that the lift without glass assemblies goes up quickly due to the reduced weight.

- Read the operating instructions completely before starting up and follow the safety instructions.
- Keep the operating instructions in a place where they can be accessed by everyone.

- Ensure that only trained staff work with the appliance.
- Follow the safety instructions, guidelines, occupational health and safety and accident prevention regulations. **When working under a vacuum in particular!**
- Wear your personal protective equipment in accordance with the hazard category of the medium to be processed. There may be a risk of:
 - splashing liquids,
 - body parts, hair, clothing and jewellery getting caught,
 - injury as a result of glass breakage.



Inhalation of or contact with media such as poisonous liquids, gases, spray mist, vapours, dusts or biological and microbiological materials can be hazardous to user.

- Set up the device in a spacious area on an even, stable, clean, non-slip, dry and fireproof surface.
- Ensure that there is sufficient space above the device as the glass assembly may exceed the height of the device.
- Prior to each use, always check the device, accessories and especially the glass parts for damage. Do not use damaged components.
- Ensure that the glass assembly is tension-free! Danger of cracking as a result of:
 - stress due to incorrect assembly,
 - external mechanical hazards,
 - local temperature peaks.
- Ensure that the stand does not start to move due to vibrations respectively unbalance.
- Beware of hazards due to:
 - flammable materials,
 - combustible media with a low boiling temperature,
 - glass breakage.



Only process and heat media that has a flash point higher than the adjusted safe temperature limit of the heating bath that has been set. The safe temperature limit of the heating bath must always be set to at least 25 °C lower than the fire point of the media used. (acc. to EN 61010-2-010)

- Do **not** operate the appliance in explosive atmospheres, with hazardous substances or under water.
- Only process media that will not react dangerously to the extra energy produced through processing. This also applies to any extra energy produced in other ways, e.g. through light irradiation.
- Tasks with the device must only be performed when operation is monitored.
- Operation with excess pressure is not permitted (for cooling water pressure see "Technical Data").
- Do not cover the ventilation slots of the device in order to ensure adequate cooling of the drive.
- There may be electrostatic discharges between the medium and the drive which could pose a direct danger.
- The appliance is not suitable for manual operation (except lift movement).
- Safe operation is only guaranteed with the accessories described in the "Accessories" chapter.
- Refer to the operating instructions for the heating bath.
- Refer to the operating instructions for the accessories, e.g. vacuum pump.
- Position the positive pressure outlet of the vacuum pump under a fume hood.
- Only use the device under an all side-closed exhaust, or a comparable protective device.
- Adapt the quantity and the type of distill and to the size of the distillation equipment. The condenser must work properly. Monitor the cooling water flow rate at the condenser outlet.
- The glass equipment must always be ventilated when working under normal pressure (e.g. open outlet at condenser) in order to prevent a pressure build-up.

- Please note that dangerous concentrations of gases, vapors or particulate matter can escape through the outlet at the condenser. Take appropriate action to avoid this risk, for example, downstream cold traps, gas wash bottles or an effective extraction system.
- Evacuated glass vessels must not be heated on one side; the evaporating flask must rotate during the heating phase.
- The glassware is designed for operation under a vacuum of down to 2 mbar. The equipment must be evacuated prior to heating (see chapter "Commissioning"). The equipment must only be aired again after cooling. When carrying out vacuum distillation, uncondensed vapours must be condensed out or safely dissipated. If there is a risk that the distillation residue could disintegrate in the presence of oxygen, only inert gas must be admitted for stress relief.



Avoid peroxide formation. Organic peroxides can accumulate in distillation and exhaust residues and explode while decomposing! Keep liquids that tend to form organic peroxides away from light, in particular from UV rays and check them prior to distillation and exhaust for the presence of peroxides. Any existing peroxides must be eliminated. Many organic compounds are prone to the formation of peroxides, e.g. dekalin, diethyl ether, dioxane, tetrahydrofuran, as well as unsaturated hydrocarbons, such as tetralin, diene, cumene and aldehydes, ketones and solutions of these substances.



The heating bath, tempering medium, evaporation flask and glass assembly can become hot during operation and remain so for a long time afterwards! Let the components cool off before continuing work with the device.



Avoid delayed boiling! Never heat the evaporating flask in the heating bath without switching on the rotary drive! Sudden foaming or exhaust gases indicate that flask content is beginning to decompose. Switch off heating immediately. Use the lifting mechanism to lift the evaporation flask out of the heating bath. Evacuate the danger zone and warn those in the surrounding area!

Safety lift

When the device is switched off or the power supply disconnected, the internal safety lift removes the evaporating flask from the heating bath.

The safety lift at loss of power is designed for a maximum total weight (glassware and solvent) of 3.1 kg.

Sample calculation of the maximum load with vertical glassware and a 1 litre flask:

Condenser + receiving flask + evaporating flask + fittings =
1200 gr + 400 gr + 280 gr + 100 gr = 1980 gr

Maximum loading of solvent = 3100 gr – 1980 gr = 1120 gr

Due to the design, operation of the safety lift cannot be guaranteed for higher loads!

When using other types of condensers such as dry ice or intensive condensers, and also when using return distillation distributors with slip-on condensers, it may be necessary to reduce the load by the amount of the added weight of the glass apparatus.

Thus, prior to distillation, check whether the lift, laden with the glassware and distillation material, rises when power is lost.

The safety lift must be checked daily prior to operation!

Attach the maximum total weight of 3.1 kg to the lift. Manually move the lift to the lowest position and press the "Power" key on the front panel or the main switch on the back right side of the device.

The evaporating flask is lifted out of the heating bath.

If the safety lift does not work, please contact the **IKA** Service department.

For the evaporating equipment (evaporating flask plus contents), the maximum permissible weight is 3.0 kg! Loads greater than this risk breakage of glass at the steam pipe!

Ensure that the safety lift has been powered down.

When working with large loads, always use low speeds.

Unbalanced loads can result in breakage of the steam pipe!

- A vacuum may be formed inside the glassware in the case of power outage. The glassware must be vented manually.



Never operate the device when the evaporation flask is rotating and the lift is raised. Always lower the evaporation flask into the heating bath first before starting the rotation drive. Otherwise hot tempering medium may be sprayed out!

- Set the speed of the drive so no tempering medium is sprayed out as a result of the evaporation flask rotating in the heating bath. If necessary reduce the speed.
- Do not touch rotating parts during operation.
- Imbalance may result in uncontrolled resonance behavior of the device or assembly. Glass apparatus may be damaged or destroyed. In the event of unbalance or unusual noises, switch off the appliance immediately or reduce the speed.
- The appliance does not start up again automatically following a cut in the power supply.
- The device is only disconnected from the power supply network if the device power switch is off or the plug is pulled out.
- The socket for the mains cord must be easily accessible.

For protection of the equipment

- The voltage stated on the type plate must correspond to the mains voltage.
- Socket must be earthed (protective ground contact).
- Removable parts must be refitted to the appliance to prevent the infiltration of foreign objects, liquids, etc.
- Protect the appliance and accessories from bumps and impacts.
- The appliance may only be opened by experts.



DANGER!

- ☞ Take care! Fast lift movement without glassware because of spring inside!
- ☞ Shut down device only in upper position!

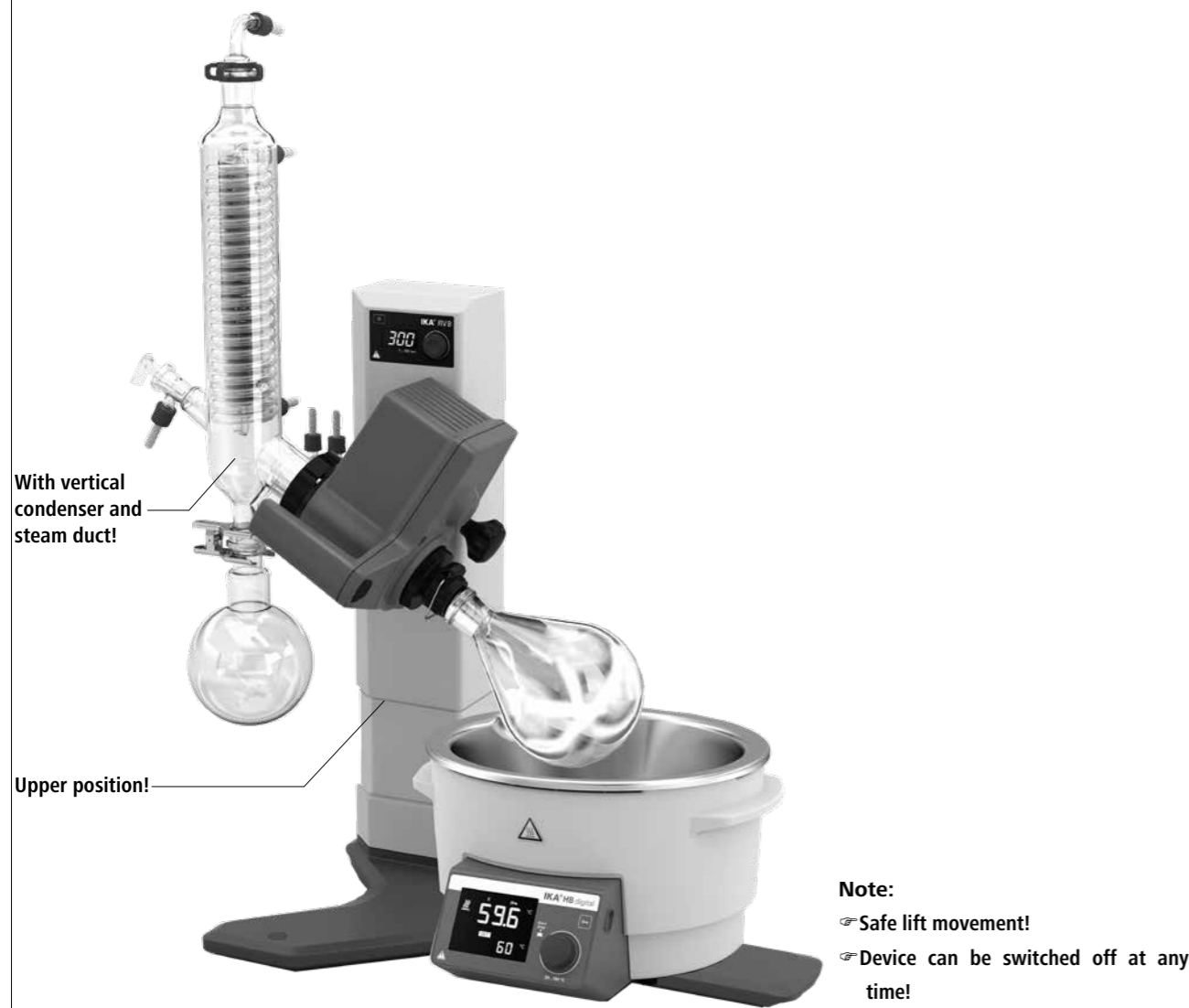

Note:

- ☞ Safe lift movement!
- ☞ Device can be switched off at any time!

Intended use

• Use

Together with the accessories recommended by IKA, the device is suitable for:

- quick and gentle distillation of liquids,
- evaporation of solutions and suspensions,
- crystallization, synthesis or cleaning of fine chemicals,
- drying of powder and granulate material,
- recycling of solvents.

Mode of operation: Tabletop device

• Area of use

Indoor environments similar to that a laboratory of research, teaching, trade or industry area.

The safety of the user cannot be guaranteed:

- if the device is operated with accessories that are not supplied or recommended by the manufacturer,
- if the device is operated improperly or contrary to the manufacturer's specifications,
- if the device or the printed circuit board are modified by third parties.

• Further remarks

Legal bases and country-specific characteristics, especially for medicine and food:

The operator is responsible for compliance with the laws and regulations applicable to him.

Unpacking

• Unpacking

- Please unpack the device carefully
- In the case of any damage a report must be sent immediately (post, rail or forwarder)

• Contents of package

	Drive RV 8	Heating bath HB digital	Vertical glassware RV 10.1	Vertical glassware RV 10.10 coated	Serrated washer M6	Cylindrical M6x25	Ring spanner	Desktop switching RV 10.8001 Seal	Foot	Right-angle T20	HEXAGON DIN911 SW5	Holding bracket	Condensate flask	Screwed Plug D	Screwed -Joint Cap	Tube clip D=9mm	Operating instructions	Base	Vapour tube	Power cable
Package 1 / RV 8 V	1	1	1		4	4	1	1	1	1	1	1	1	1	2	2	1	1	1	2
Package 2 / RV 8 VC	1	1		1	4	4	1	1	1	1	1	1	1	1	2	2	1	1	1	2
Package 3 / RV 8 flex	1	1			4	4	1	1	1	1	1	1	1	1	2	2	1	1	1	2

Contents of package RV 8

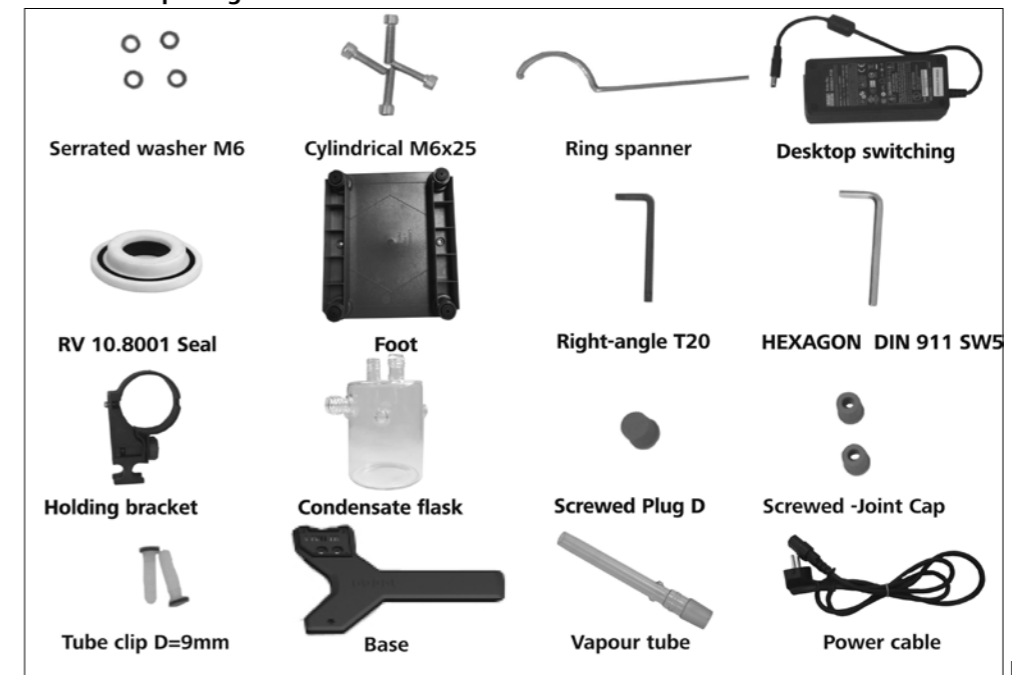

Fig. 6

Useful information

Distillation is a thermal separating process for liquid compounds based on substance-specific, pressure-dependent boiling points through evaporation and subsequent condensation.

The boiling point temperature decreases with decreasing external pressure which means that work is usually done under reduced pressure. In this way the heating bath can be maintained at a constant temperature (e.g. 60 °C). Using the vacuum, the boiling point is set with a steam temperature of approx. 40 °C. The cooling water for the condensation condenser should not be warmer than 20 °C (60-40-20 rule).

A chemical resistant membrane pump with a vacuum controller should be used to create the vacuum. The pump is protected from solvent residue by the addition of a Woulff bottle and/or a vacuum separator.

Working with a jet pump to create a vacuum can only be recommended to a limited extent as the solvents may contaminate the environment when using these systems.

Speed, temperature, flask size and system pressure all affect the evaporator air capacity.

The optimum capacity of the flow-through condenser is approx. 60%.

This corresponds to condensation on approx. 2/3 of the cooling coil. With larger capacities there is the risk that the uncondensed solvent vapor will be extracted.



The device is equipped with a Lift safety unit.

If the power cuts out, the evaporation flask is automatically lifted out of the heating bath by an integrated gas spring.

“CAUTION! The safety lift must be checked daily before use. See safety notes / safety lift ! “

The glass apparatus can be evacuated after power outage!

When using other types of condensers such as dry ice or intensive condensers as well as when using return distillation distributors with slip-on condensers, it may be necessary to reduce the mass of the media to compensate for the mass of this additional glass-ware. Thus, prior to distillation, check whether the lift goes up without power when laden with the glass and distillation material.

The device is designed for operation with a cooling water supply system (e.g. laboratory thermostat), but can also be run off a water supply line. Please refer to the Technical Data for information on cooling water pressure, temperature constancy, and flow rate.

Installation

Drive RV 8

1.) Mount the base to the lift. (Fig. 7)

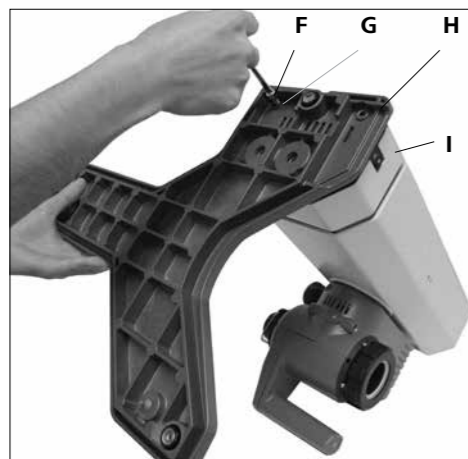

Fig. 7

- Apply Cylindrical M6x25 (F) (4x) and Serrated washer M6 (G) (4x) to mount base (H) with Lift Unit (I) after you unpack the package. (Fig. 7)

2.) Remove transportation lock (Fig. 8)

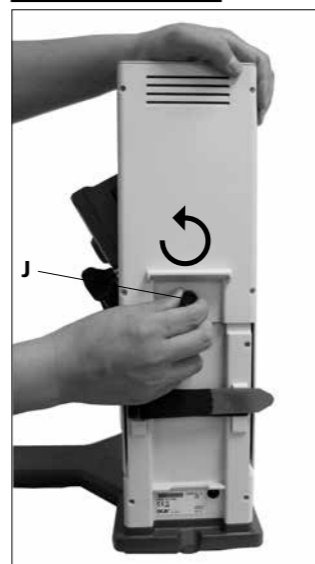

Fig. 8

- Hold the lift with your hand on the height position and remove the thumb screw (J) by turning counterclockwise on the back of the appliance.

Take care! DANGER!

Once the transportation lock has been removed, the lift moves fast to its upper end position. The distance is approx. 120 mm.

3.) Fix the Desktop switching. (Fig. 9)

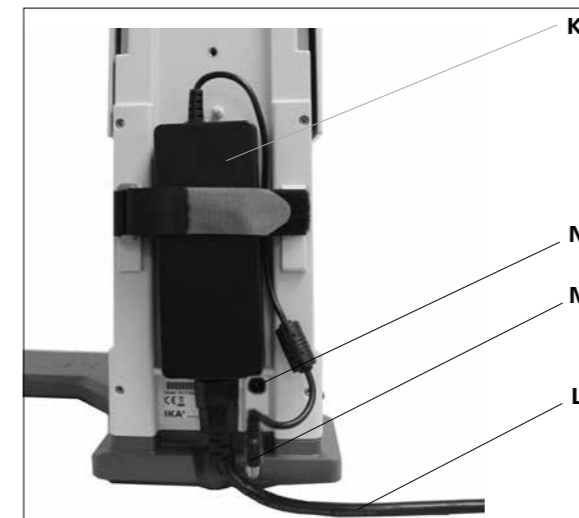

Fig. 9

- Attach the switching adapter (K) on the rear side. Secure it with the Velcro, by contracting both tabs on the switching adapter. The Velcro must not be below the switching adapter.
- Connect the Low-voltage connector (M) to the connection socket (N). (Fig. 9)
- Plug the power cord (L) in the switching adapter and connect it to the power source.
- Observe the valid supply voltage.

4.) Fix the Holding bracket (Fig.10)



Fig.10

5.) Insert the bottle and attach the supplied hose connectors to the bottle. (Fig. 11)



Fig.11

6.) Adjust the angle of the rotation head. (Fig. 12)

- Remove the clamping device for the angle setting of the rotation drive on the right side of the lift by rotating the knob counterclockwise.



Fig.12

7.) Set the drive at an angle of approx. 30°. (Fig. 13)



Fig.13

- Then, secure the rotary drive against rotation by tightening the adjustable knob clockwise.

Glassware

NOTE: Please read the operating instructions of the glassware for the safe handling of laboratory glassware !

- There is a locking knob (P) for locking or unlocking the locking device (O).

If a red mark (Q) is shown, the locking device is unlocked, otherwise it is locked.

To lock or unlock the locking device (O), push the locking knob (P) to the end position.

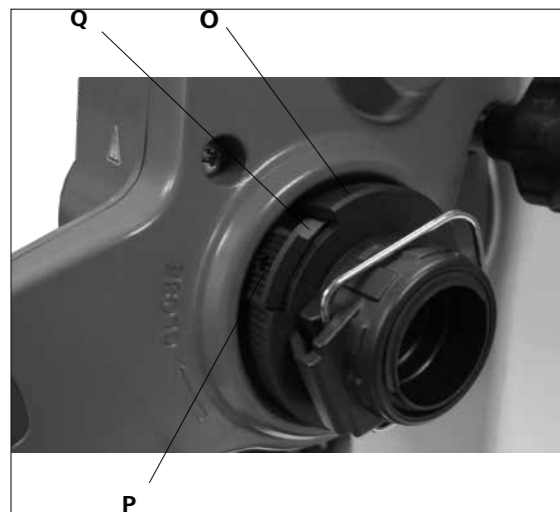

Fig. 14a

- Open the locking device (O) on the drive head by turning it 60° counterclockwise. Then you can see a red mark (Q) .

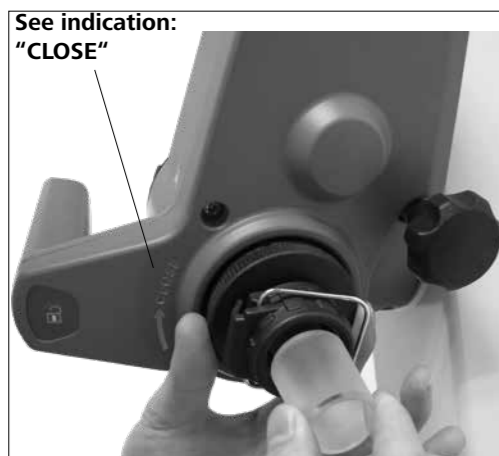

Fig. 14b

- Feed the vapour tube (R) in until it stops.
- Then, lock the locking device (O) by turning it clockwise by 60°.

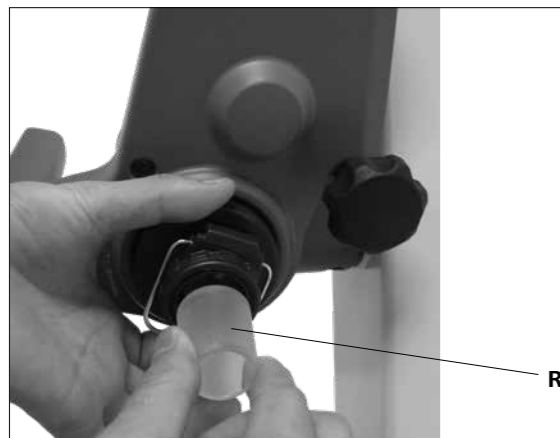

Fig. 14c

- Pushing the lock knob (P) to the end position, the red mark (Q) should be covered and invisible.
- The vapour tube is not allowed to be pulled out!
- Check the correct axial locking device on the vapour tube.
- Keep the red mark (Q) invisible.

Fit & unfit the evaporation flask / push off mechanism

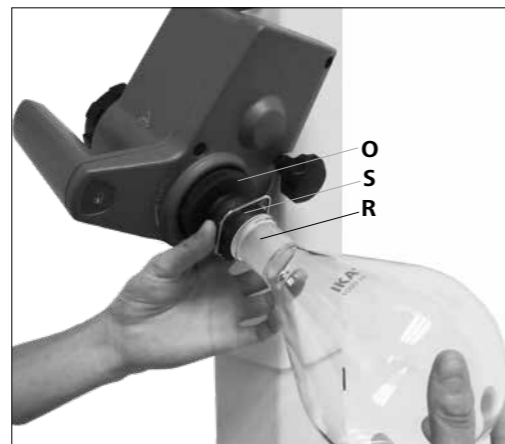

Fig. 15a

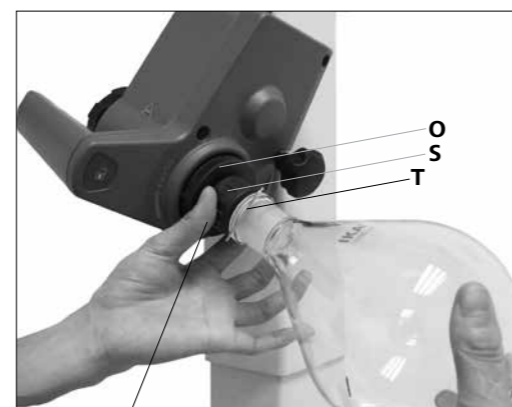

Fig. 15b

Turn clockwise (↻) for tight-fitting
Turn counterclockwise (↺) for loosen tight-fitting

Mount the evaporation flask:

- Place the evaporation flask on the Vapour tube (R). (Fig. 15a)
- Turn the plastic nut (S) with the clip (T) counterclockwise until the clip can be put on the flange. (Fig. 15b)
- Now turn the plastic nut clockwise until the clamp is hard up against the flange. When doing so, hold the locking device (O) on the steam pipe.

Remove the evaporation flask:

- Hold the locking device (O) and loosen the plastic nut by turning it counterclockwise. This releases a tightly clamped evaporating flask.
- Hold the evaporating flask at the flange and open the jaws of the clamp.
- Remove the evaporating flask.
- Check that the locking of vapour tube is still closed!

- Place the RV 10.8001 condenser seal (U) in the condenser receptacle and fit the glassware to the device according to the assembly instructions. (Fig. 16, 17 and 18)



Fig. 16

Mount the condenser

- Place the cap nut into the condenser, and then put the spring ring to the flange of the condenser (V).
- Place the condenser on the rotary drive (W) and tighten the cap nut by hand. (Fig. 17)

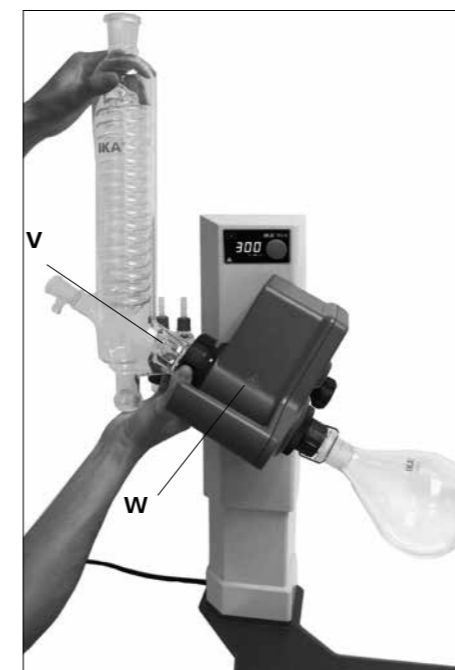

Fig. 17

- Fix the receiving flask and hose connectors as shown. See also operating manual of glassware. (Fig. 18)



Fig. 18

Mounting the washer

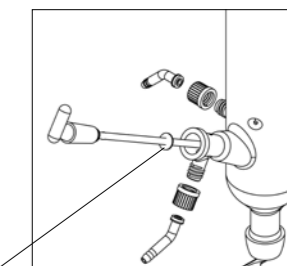

Fig. 19a

Drainage washer



Fig. 19b

Note: Pay attention to the correct position of the washer.

Removing the condenser

- Use the ring spanner provided to loosen union nuts that are tightly fitted.
- Loosen the union nut by turning anticlockwise.

Description of special condensers

(see products/accessories at www.ika.com)

• RV 10.3 Vertical-intensive condenser with manifold

This vertical-intensive condenser features a double jacket design for particularly efficient condensation. Also available with coating (RV 10.30)

• RV 10.4 Dry ice condenser

Dry ice condenser for distilling low-boiling solvents. Cooling by dry ice, no cooling water required. Maximum condensation thanks to low temperatures.

Also available with coating (RV 10.40)

- **RV 10.5 Vertical-condenser with manifold and cut-off valve for reflux distillation**

Also available with coating (RV 10.50)

- **RV 10.6 Vertical-intensive condenser with manifold and cut-off valve for reflux distillation**

This vertical-intensive action condenser features a double jacket design for particularly efficient reflux distillation.

Also available with coating (RV 10.60)

Hose system

- Connect the water hoses (**H₂O**) to the condenser according to the counter-flow principle. (Fig. 20)
- Install the vacuum connections to the condenser, Wouff bottle, vacuum controller with valve and vacuum pump.
- Always connect the vacuum hose (**vac**) to the condenser at the highest point to minimize solvent losses during suctioning.
- Use standard laboratory vacuum hoses with an inside diameter of 8 mm and a wall thickness of 5 mm (see accessories).

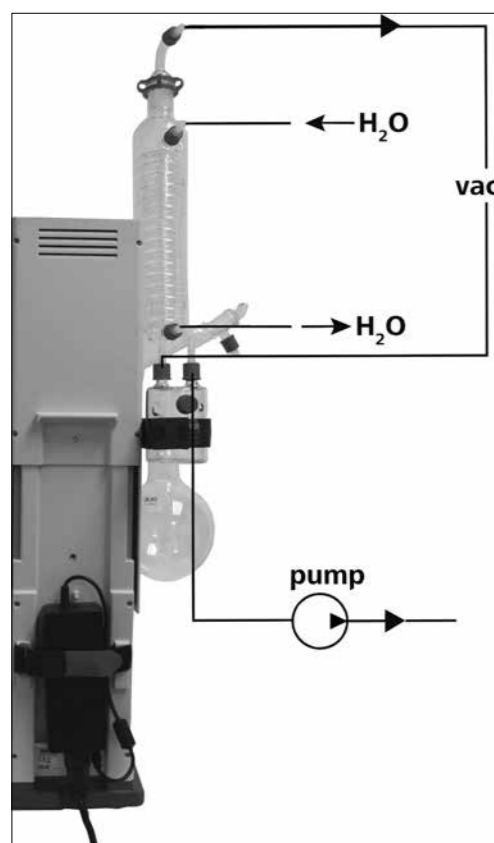

Fig. 20

Heating bath



Refer to the chapter entitled "Operation" in the operating instructions of heating bath!

- **Assemble the foot of the heating bath**

For operation of the heating bath in combination with the RV 8, the foot plate supplied must be fitted to the heating bath.

Caution: It is not permitted to use heating bath fitted with a foot plate in combination with any other type of rotary evaporator.

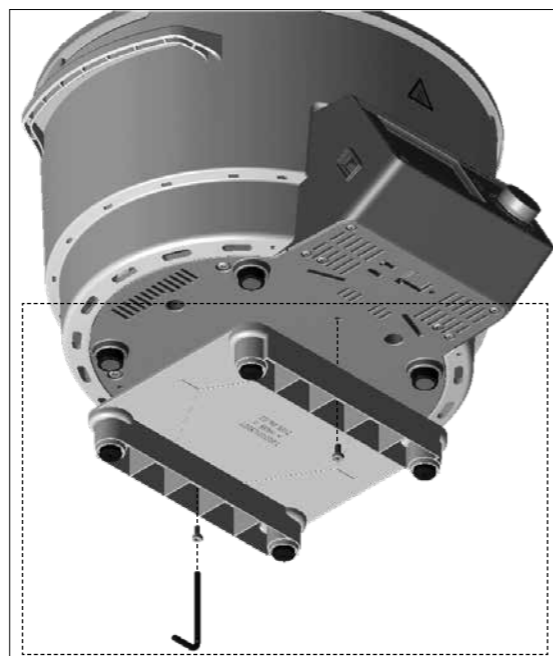

Fig. 21

- Place the heating bath on the stand of the rotation drive and push it into the left position. (Fig. 22)



Fig. 22

Commissioning

The unit is ready for service when the mains plug has been plugged in.



Fig.5

Filling the evaporation flask:

You can fill the evaporation flask manually prior to creating the vacuum. The evaporation flask should not be filled more than half its volume.



The maximum allowed load (evaporation flask and contents) is 3 kg.

Filling medium by vacuum: prior to filling the evaporation flask, a vacuum controller is used to regulate the glass apparatus to the target pressure.

- Now fill the evaporation flask using the backfeed line.
- Due to the vacuum present, the solvent is suctioned into the evaporation flask. This enables you to keep solvent loss due to suctioning to a minimum.

Setting up the heating bath:

Also refer to the operating instructions for the heating bath!

- Move the lift to the bottom position and check the position of the heating bath in relation to the evaporation flask. When using larger evaporation flasks (2 or 3 liters) or depending on the angle of the rotation drive, you can move the heating bath to the right.
- Fill the heating bath with the tempering medium until the evaporation flask is surrounded by tempering medium to 2/3 of its volume.
- Switch on the rotation drive and slowly increase the speed.
Note: Avoid creating waves.
- Switch on the heating bath using the main on/off switch.
Note: Avoid stress on the glass due to different evaporation flask and heating bath temperatures when lowering the evaporation flask into the heating bath!

Function keys (Fig.3)



Fig.3

- **"Power" key (1)**

When the power switch (5) is switched on, the device will be in "activated" mode.

Touch the "Power" key (1) for about 1 second, the status of the device will be changed from "activated" mode to "stand-by" mode.

Touch the "Power" key again shortly, the status of the device will be changed back to "activated" mode immediately.

- **Display window/speed (2)**

Display (2) shows "8.8.8."

then Softwareversion "X.X".

Display shows "set value".

Note: The device is not deenergized until the mains power supply has been interrupted, for instance by unplugging the power cable.

- **Rotating knob (3)**

To start the rotation, press the rotary knob.

The indicator flashes until the set speed in rpm (revolution per minute) is reached.

By turning the rotary knob, the speed can be changed.

To stop the rotation, press the rotary knob again.

The last displayed speed value is stored.

Lift position key (4&6) (Fig. 23a and Fig. 23b)

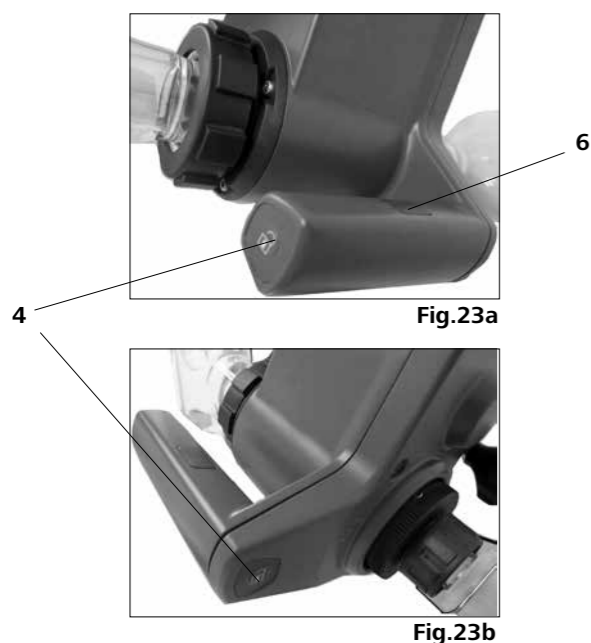

To adjust the lift position, grasp the handle and press the left or right lock button (4).
The hand must rest on the sensor (6).
Note: Hand detection sensor (6), only to be touched by hand, do not press!
The lift lock is unlocked and you can move the lift up and down. Release the lock button or remove the hand from the lift, the lift is locked in the adjusted position.
When locking and unlocking, a clear "click" sound is heard.

Assembling the stand pillar RV 8.1 (Accessories)

No stand is required if the condenser has been properly fitted and secured by tightening the condenser union nut on the rotary drive.
The purpose of the stand is solely to prevent the condenser twisting.

WARNING

Caution: If the RV 8.1 stand is fitted incorrectly, the strong forces at the Velcro strap can cause stresses within the glass, which in turn can cause damage to the glass condenser.

After the condenser has been fitted, the RV 8.1 stand is attached to the rotary drive. Make sure that the condenser is installed parallel to the lift body.

- Guide the stand rod through the hole on the underside of the rotary drive,
- Screw the knurled screw into the tapped hole but do not tighten it,
- Move the stand until the upper rubber sleeve rests against the glass condenser,
- Tighten the knurled screw finger-tight,
- Secure the condenser to the stand using the pre-fitted Velcro strap.



Fig.24

Maintenance and cleaning

The device is maintenance-free. It is only subject to the natural wear and tear of components and their statistical failure rate.

Cleaning

For cleaning disconnect the mains plug!
Use only cleaning agents which have been approved by IKA to clean IKA devices.

These are water (with tenside) and isopropanol.

Wear protective gloves during cleaning the devices.

Electrical devices may not be placed in the cleansing agent for the purpose of cleaning.

Do not allow moisture to get into the device when cleaning.

Before using another than the recommended method for cleaning or decontamination, the user must ascertain with IKA that this method does not destroy the device.

Spare parts order

When ordering spare parts, please give:

- device type.
- serial number, see type plate.
- position number and description of spare part, see www.ika.com.
- software version.

Repair

Please only send devices in for repair that have been cleaned and are free of materials which might present health hazards.

For repair, please request the "Safety Declaration (Decontamination Certificate)" from IKA or use the download printout of it from IKA website at www.ika.com.

If your appliance requires repair, return it in its original packaging. Storage packaging is not sufficient when sending the device - also use appropriate transport packaging.

Accessories

For accessories see www.ika.com.

Error Codes

Any malfunctions during operation will be identified by an error message on the display.

Once a serious error message has been displayed, the lift moves to the top end position and the device can no longer be operated.

Proceed as follows in such cases:

- switch off device using the main switch,
- carry out corrective measures,
- restart device.

Error code	Cause	Effect	Correction
E03	Temperature inside the device is too high	Room temperature > 40 °C	- Switch off the device - Let the device cool down - Check the location (see Technical data)
E04	Target speed is not reached Motor blocked	Load too large Cable break	- Reduce the volume in the evaporator
E09	Flash memory storage error	Transmission error	- Turn the unit off and on again

If the actions described fail to resolve the fault or another error code is displayed, then take one of the following steps:

- contact the service department,
- send the device for repair, including a short description of the fault.

Technical data

Operating voltage range	Vac	(100 – 240) ± 10%
Rated voltage	Vac	100 – 240
Frequency	Hz	50 / 60
Rated power of RV 8 device (without heating bath)	W	75
Rated power (max.) of switching adaptor	W	90
Speed	rpm	5 – 300
Speed tolerance	Set speed: < 100 rpm Set speed: ≥ 100 rpm	rpm % ± 1 ± 1
Speed display	mm	digital
Dimensions of visible display area (W x H)		37 x 18
Display		7 segments display
Smooth start		yes
Lift		manual
Stroke	mm	120
Head angle adjustable		0° – 45°
Cooling surface	cm ²	1500
Cooling water flow rate min.	l/h	30
Cooling water flow rate max.	l/h	100
Cooling water pressure max.	bar	1
Perm. On-time	%	100
Perm. ambient temperature	°C	5 – 40
Perm. relative humidity	%	80
Protection acc. to DIN EN 60529		IP 20
Protection class		I
Contamination level		2
Weight (no glassware; no heating bath)	kg	12.5
Dimensions (W x D x H)	mm	595 x 390 x 615
Operation at a terrestrial altitude	m	max. 2000

Subject to technical changes!

Solvent table (excerpt)

Solvent	Formula	Pressure for boiling point 40 °C in mbar (For HB approx. 60 °C)
Acetic acid	C ₂ H ₄ O ₂	44
Acetone	C ₃ H ₆ O	556
Acetonitrile	C ₂ H ₃ N	226
N-Amylalcohol	C ₅ H ₁₂ O	11
n-Pentanol	C ₅ H ₁₀ O	11
n-Butanol	C ₄ H ₁₀ O	25
tert. Butanol	C ₄ H ₁₀ O	130
2-Methyl-2-Propanol	C ₄ H ₁₀ O	130
Butylacetate	C ₆ H ₁₂ O ₂	39
Chlorobenzene	C ₆ H ₅ Cl	36
Chloroform	CHCl ₃	474
Cyclohexane	C ₆ H ₁₂	235
Dichloromethane	CH ₂ Cl ₂	atm. press.
Methylenechloride	CH ₂ Cl ₂	atm. Press.
Diethylether	C ₄ H ₁₀ O	atm. press.
1,2,-Dichloroethylene (trans)	C ₂ H ₂ Cl ₂	751
Diisopropylether	C ₆ H ₁₄ O	375
Dioxane	C ₄ H ₈ O ₂	107
Dimethylformamide (DMF)	C ₃ H ₇ NO	11
Ethanol	C ₂ H ₆ O	175
Ethylacetate	C ₄ H ₈ O ₂	240
Ethylmethylketone	C ₄ H ₈ O	243
Heptane	C ₇ H ₁₆	120
Hexane	C ₆ H ₁₄	335
Isopropylalcohol	C ₃ H ₈ O	137
Isoamylalcohol	C ₅ H ₁₂ O	14
3-Methyl-1-Butanol	C ₅ H ₁₂ O	14
Methanol	CH ₄ O	337
Pentane	C ₅ H ₁₂	atm. press.
n-Propylalcohol	C ₃ H ₈ O	67
Pentachloroethane	C ₂ HCl ₅	13
1, 1, 2, 2, -Tetrachloroethane	C ₂ H ₂ Cl ₄	35
1, 1, 1, -Trichloroethane	C ₂ H ₃ Cl ₃	300
Tetrachloroethylene	C ₂ Cl ₄	53
Tetrachloromethane	CCl ₄	271
Tetrahydrofurane (THF)	C ₄ H ₈ O	357
Toluene	C ₇ H ₈	77
Trichloroethylene	C ₂ HCl ₃	183
Water	H ₂ O	72
Xylene	C ₈ H ₁₀	25

Warranty

In accordance with **IKA** warranty conditions, the warranty period is 24 months. For claims under the warranty please contact your local dealer. You may also send the machine directly to our factory, enclosing the delivery invoice and giving reasons for the claim. You will be liable for freight costs.

The warranty does not cover worn out parts, nor does it apply to faults resulting from improper use, insufficient care or maintenance not carried out in accordance with the instructions in this operating manual.