

Hoefer TE42 and TE62

Transfer electrophoresis units

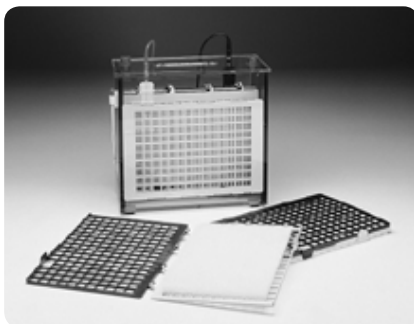



Contents

Important Information	ii
Waste Electrical and Electronic Equipment (WEEE)	vii
Transfer Electrophoresis Unit function and description	1
Specifications	2
Operating instructions	4
Care and maintenance	12
Mains power module	13
Troubleshooting	15
Electrotransfer notes	17
Bibliography	24
Ordering information	26

Important Information – English

- If this equipment is used in a manner not specified by Hoefer, Inc. the protection provided by the equipment may be impaired.
- This instrument is designed for indoor laboratory use only.
- Only accessories and parts approved or supplied by Hoefer, Inc. may be used for operating, maintaining, and servicing this product.
- Only use a power supply that is CE marked or safety certified by a nationally recognized testing laboratory.
- The safety lid must be in place before connecting the power supply leads to a power supply.
- Turn all power supply controls off and disconnect the power leads before removing the safety lid.
- Circulate only water or 50/50 water/ethylene glycol through the heat exchanger if so equipped. Do not connect the heat exchanger to a water tap or any coolant source where the water pressure is unregulated.
- Never introduce antifreeze or any organic solvent into any part of the instrument. Organic solvents will cause irreparable damage to the unit!
- Do not operate with buffer temperatures above the maximum specified technical specifications. Overheating will cause irreparable damage to the unit!

Důležité Informace – Czech

- Pokud by toto zařízení je použito způsobem, který není podle Hoefer, Inc. ochrana poskytovaná na základě zařízení může být narušena.
- Tento nástroj je určen pro vnitřní použití v laboratoři pouze.
- Pouze příslušenství a části schválené, nebo poskytnuté Hoefer, Inc. mohou být použity pro provoz, údržbu, a údržbě tohoto výrobku.
- zdroj napájení používají jen že je opatřen označením CE osvědčena nebo bezpečnost vnitrostátně uznanými zkušebními laboratoř.
- Bezpečnosti lid musí být zavedena před připojením napájecí zdroj napájení vede k.
- Turn veškeré napájení kontroly vypnuto a odpojit před odběrem energie vede bezpečnostní víko.

- Rozeslat pouze voda nebo 50/50 voda/ethylenglykolu prostřednictvím výměník tepla je li to vybavena. Nemají připojení výměník tepla s vodními setřepná nebo jakékoli chladicí kapaliny zdroje, kde tlak vody je neregulováno.
- Nikdy zavést prostředek proti zamrznutí nebo jakákoli organická rozpouštědla do jakékoli části z tohoto nástroje. Rozpuštěním způsobí nenapravitelné poškození jednotka!
- Nejsou provozována s pufru teplotách nad maximální stanovenou technickými specifikacemi. Přehřátí způsobí nenapravitelné poškození jednotka!

Vigtig Information – Danish

- Hvis dette udstyr bruges i en måde ikke specificeret ved Hoefer, Inc. den beskyttelse, som er blevet forsynet af udstyret kan måske svækkes.
- Dette instrument er designet for indendørs laboratoriumbrug bare.
- Bare tilbehør og del godkendte eller forsynede ved Hoefer, Inc. kan måske bruges for drive, funktionsfejl, og betjening dette produkt.
- bruger Bare en strømforsyning, der er CE markerede eller sikkerhed, som er blevet attesteret af en, som nationalt er blevet anerkendt prøve laboratorium.
- Sikkerhedslåget må være på plads før forbinding strømforsyningsblyet til en strømforsyning.
- Drejer alle strømforsyningskontroller af og afbryder kraftblyet før fjerning sikkerhedslåget.
- Cirkulerer bare vand eller 50/50 vand/ethylene glykol gennem varmeveksleren i så fald udrustet. Forbind ikke varmeveksleren til en vandhane eller nogen kølemiddelkilde hvor vandtrykket er unreguleret.
- Introducerer Aldrig antifreeze eller noget organisk opløsningsmiddel ind i nogen del af instrumentet. Organiske opløsningsmidler vil forårsage uboelig skade til enheden!
- Driver ikke med stødpudetemperaturer over maksimummet specificerede tekniske specifikationer. Overhedning vil forårsage uboelig skade til enheden!

Belangrijke Informatie – Dutch

- Indien deze uitrusting in een manier wordt gebruikt die niet door Hoefler, Inc. is gecertificeerd de bescherming die door de uitrusting is verzorgd kan worden geschaad.
- Dit instrument is voor binnenlaboratoriumgebruik enkel ontworpen.
- Enkel onderdelen en delen keurden goed of leverden door Hoefler, Inc. kan voor het bedienen worden gebruikt, handhavend en onderhouden van dit product.
- gebruik Enkel een netvoeding die CE is markeerde of veiligheid die door een is gecertificeerd die nationaal is herkend testene laboratorium.
- Het veiligheidsdeksel moet in plaats voor het verbinden van de netvoeding leidt tot een netvoeding zijn.
- Doe alle netvoedingscontroles Uit en koppel los de machtleiding voor het verwijderen van het veiligheidsdeksel.
- Circuleer enkel water of 50/50 water/ethyleen-glycol door de hitte exchanger zo ja uitrust. Verbind de hitte exchanger naar een waterkraan of koelmiddelbron niet waar de waterdruk niet geregulariseerd is.
- Stel Nooit antivriesmiddel of organische oplosmiddelen in deel van het instrument voor. Organische oplosmiddelen zullen onherstelbare schade aan de eenheid veroorzaken!
- Bedien niet met buffertemperaturen boven het maximum specificieerde technische specificaties. Oververhittend zal onherstelbare schade aan de eenheid veroorzaken!

Tärkeää Tietoa – Finnish

- Jos tätä varusteita käytetään tavassa ei määritetty Hoefler, Inc. suojele ehkäisty varusteille saattaa olla avuton.
- Tämä väline suunnitellaan sisälaboratoriokäytölle vain.
- Vain lisävarusteet ja osat hyväksyivät tai toimitti Hoefler, Inc. oheen ää voi käyttää käyttämiselle, valvoalle, ja servicing tämä tuote.
- Vain käyttää käyttöjännitettä joka on CE merkitsi tai turvallisuus joka on todistanut aidoksi ohi joka

on kansallisesti tunnustettanut testaaminen laboratorioriota.

- Turvallisuuskansia täytyy olla paikallaan ennen yhdistäminen käyttöjännitelyjyää käyttöjännitteeseen.
- Kiertää kaikki käyttöjännitevalvonnot ja irrottaa valtalyijyt ennen poistaminen turvallisuuskannta.
- Kiertää vain vesi tai 50/50 vesi/ethyleeni glycol siinä tapauksessa varustetun lämmönvaihtimen läpi. Älä yhdistä lämmönvaihdinta vesinapautukseen eikä jäähdytysnestelähteeseen, missä vesipaine on unregulated.
- Pakkasneste eikä orgaaninen liuotin välineen osassa ei esitele Koskaan. Orgaaniset liuottimet aiheuttavat korvaamattoman vahingon yksikköön!
- Ei käytä puskuria yllä olevia lämpötiloja enintään määritetyillä teknisillä täsmennyksillä. Ylikuumeneminen aiheuttaa korvaamattoman vahingon yksikköön!

Information Importante – French

- Si cet équipement est utilisé dans une manière pas spécifique par Hoefler, Inc. la protection fourni par l'équipement pourrait être diminuée.
- Cet instrument est conçu pour l'usage de laboratoire intérieur seulement.
- Seulement les accessoires et les parties ont approuvé ou ont fourni par Hoefler, Inc. pourrait être utilisé pour fonctionner, maintenir, et entretenir ce produit.
- utilise Seulement une alimentation qui est CET a marqué ou la sécurité certifié par un nationalement reconnu essayant le laboratoire.
- Le couvercle de sécurité doit être à sa place avant connecter l'alimentation mene à une alimentation.
- Tourner tous contrôles d'alimentation de et débrancher les avances de pouvoir avant enlever le couvercle de sécurité.
- Circuler seulement de l'eau ou 50/50 glycol d'eau/éthylène par l'échangeur de chaleur si si équipé. Ne pas connecter l'échangeur de chaleur à un robinet d'eau ou à la source d'agent de refroidissement où la pression d'eau est non régulée.
- Ne Jamais introduire d'antigel ou du dissolvant organique dans n'importe quelle partie de

l'instrument. Les dissolvants organiques causeront des dommages irréparables à l'unité!

- Ne pas fonctionner avec les températures de tampon au-dessus du maximum a spécifié des spécifications techniques. La surchauffe causera des dommages irréparables à l'unité!

Wichtige Informationen – German

- Wenn diese Ausrüstung gewissermaßen nicht angegeben durch Hoefel, Inc. verwendet wird, kann der durch die Ausrüstung zur Verfügung gestellte Schutz verschlechtert werden.
- Dieses Instrument wird für den Innenlaborgebrauch nur dafür entworfen.
- Nur Zusätze und Teile genehmigten oder lieferten durch Hoefel, Inc. kann für das Funktionieren, das Aufrechterhalten, und die Wartung dieses Produktes verwendet werden.
- Verwenden Sie nur eine Energieversorgung, die CE gekennzeichnet oder durch ein national anerkanntes Probelaboratorium bescheinigte Sicherheit ist.
- Der Sicherheitsdeckel muss im Platz vor dem Anschließen der Energieversorgung sein führt zu einer Energieversorgung.
- Alle Energieversorgungssteuerungen abdrehen und die Macht trennen führt vor dem Entfernen des Sicherheitsdeckels.
- Nur Wasser oder 50/50 Glykol des Wassers/ Äthylens durch den Wärmeaustauscher, wenn so ausgestattet, in Umlauf setzen. Verbinden Sie den Wärmeaustauscher mit einem Wasserklaps oder jeder Kühlmittel-Quelle nicht, wo der Wasserdruck ungeregelt wird.
- Führen Sie nie Frostschutzmittel oder jedes organische Lösungsmittel in jeden Teil des Instrumentes ein. Organische Lösungsmittel werden nicht wiedergutzumachenden Schaden der Einheit verursachen!
- Mit Puffertemperaturen über angegebenen technischen Spezifizierungen des Maximums nicht funktionieren. Die Überhitzung wird nicht wiedergutzumachenden Schaden der Einheit verursachen!

Informazioni Importanti – Italian

- Se quest'apparecchiatura è usata in un modo specificato da Hoefel, Inc. la protezione fornito dall'apparecchiatura potrebbe essere indebolita.
- Questo strumento è disegnato per l'uso di laboratorio interno solo.
- Solo gli accessori e le parti hanno approvato o hanno fornito da Hoefel, Inc. potrebbe essere usato per operare, per mantenere, e per revisionare questo prodotto.
- usa Solo un alimentatore che è CE ha marcato o la sicurezza certificato da un nacionalmente riconosciuto testando il laboratorio.
- Il coperchio di sicurezza deve essere nel luogo prima di collegare i piombi di alimentatore a un alimentatore.
- Spagne tutto i controlli di alimentatore e disinserisce i piombi di potere prima di togliere il coperchio di sicurezza.
- Circola solo l'acqua o 50/50 glicole di acqua/etilene attraverso lo scambiatore di calore se così equipaggiato. Non collegare lo scambiatore di calore a un rubinetto di acqua o qualunque fonte di refrigerante dove la pressione di acqua è sregolata.
- Non introduce mai l'antigel o qualunque solvente organico in qualunque parte dello strumento. I solventi organici causeranno il danno irreparabile all'unità!
- Non opera con le temperature di tampone al di sopra del massimo ha specificato le descrizioni tecniche. Il surriscaldamento causerà il danno irreparabile all'unità!

Viktig Informasjon – Norwegian

- Hvis dette utstyret blir brukt i en måte ikke spesifisert ved Hoefel, Inc. beskyttelsen som ha blitt gitt av utstyret kan bli svekket.
- Dette instrumentet er utformet for innendørs laboratoriumbruk bare.
- Bare tilbehør og deler godkjente eller forsynte ved Hoefel, Inc. kan bli brukt for drive, vedlikeholde, og betjene dette produktet.
- bruker Bare en kraftforsyning som er CE merket eller sikkerhet som ha blitt sertifisert av et som nasjonalt ha blitt anerkjent prøver laboratorium.

- Sikkerheten lokket må være på plass før forbindelse kraftforsyningene blyene til en kraftforsyning.
- Vender all kraftforsyningsstyring av og frakopler kreftene blyene før fjerning sikkerheten lokket.
- Sirkulerer bare vann eller 50/50 vann/ethylene glykol gjennom oppvarmingen veksleren i så fall utstyrer. Ikke forbind oppvarmingen veksleren til en vann tapp eller noe kjølemiddelkilde hvor vannet trykket er unregulated.
- Introduserer Aldri antifreeze eller noe organisk løsemiddel inn i noe del av instrumentet. Organiske løsemidler vil forårsake irreparabel skade på enheten !
- Driver med buffertemperaturer over maksimum ikke spesifiserte teknisk spesifikasjoner. Å overoppheting vil forårsake irreparabel skade på enheten !

Wazne Informacje – Polish

- Jeżeli ten sprzęt jest wykorzystywany w sposób nie określone przez Hoefer, Inc. do ochrony przewidzianej przez urządzenie może zostać obniżony.
- Instrument ten jest przeznaczony do użytku w laboratoriach kryty tylko.
- Tylko akcesoriów i części zatwierdzone lub dostarczone przez Hoefer, Inc. mogą być wykorzystane do eksploatacji, utrzymania i obsługi tego produktu.
- korzystając jedynie zasilacza że jest noszące oznakowanie CE lub bezpieczeństwa uwierzytelnione przez uznane na poziomie krajowym laboratorium badawcze.
- Bezpieczeństwo lid musi być w miejsce przed podłączeniem zasilania prowadzi do zasilania.
- Zaś wszystkie źródła zasilania urządzenia sterujące off i odłączyć moc prowadzi przed odbiorem bezpieczeństwa lid.
- Krążą tylko wody lub wody 50/50/ethylene glycol wymiennik ciepła poprzez jeśli tak wyposażone. Nie należy połączyć wymiennik ciepła woda z kranu lub jakikolwiek chłodziwo źródła, jeżeli ciśnienie wody jest niuregulowanych.
- Nigdy nie wprowadzać rozpuszczalnika organicznego przeciw zamarzaniu lub jakichkolwiek na dowolną część dokumentu. Rozpuszczalniki organiczne spowoduje nieodwracalne szkody dla jednostki!

- Nie działają w buforze temperatury powyżej maksymalnego określone specyfikacje techniczne. Przegrzania spowoduje nieodwracalne szkody dla jednostki!

Informações Importantes – Portuguese

- Se este equipamento é usado numa maneira não especificada por Hoefer, Inc. que a protecção fornecida pelo equipamento pode ser comprometida.
- Este instrumento é projectado para uso de interior de laboratório só.
- Só acessórios e partes aprovaram ou forneceu por Hoefer, Inc. pode ser usada para operar, manter, e servicing este produto.
- Só usa um estoque de poder que é CE marcou ou segurança registrada por um nacionalmente reconhecido testando laboratório.
- A tampa de segurança deve estar em lugar antes de ligar o estoque de poder leva a um estoque de poder.
- Desliga todos controles de estoque de poder e desconecta os chumbos de poder antes de retirar a tampa de segurança.
- Circulam só água ou 50/50 glicol de água/ethylene pelo exchanger de calor se for assim equiparam. Não ligue o exchanger de calor a uma torneira de água nem qualquer fonte de refrigerante onde a pressão de água é não regulado.
- Nunca introduz anticongelante nem qualquer orgânico solvente em qualquer parte do instrumento. Orgânico solvente causará agressão irreparável à unidade!
- Não opera com temperaturas de buffer acima do máximo especificou especificações técnicas. Superaquecer causará agressão irreparável à unidade!

Información Importante – Spanish

- Si este equipo es utilizado en una manera no especificado por Hoefer, Inc. la protección proporcionado por el equipo puede ser dañada.
- Este instrumento es diseñado para el uso interior del laboratorio sólo.
- Sólo accesorios y partes aprobaron o suministraron

-
- por Hoefler, Inc. puede ser utilizado para operar, para mantener, y para atender a este producto.
- Sólo utiliza una alimentación que es CE marcó o la seguridad certificada por un nacionalmente reconocido probando el laboratorio.
 - La tapa de la seguridad debe estar en el lugar antes de conectar la alimentación lleva a una alimentación.
 - Apaga todos controles de alimentación y desconecta los plomos del poder antes de quitar la tapa de la seguridad.
 - Circula sólo agua o 50/50 glicol de agua/etileno por el intercambiador de calor si ése es el caso equiparon. No conecte el intercambiador de calor a un toque de la agua ni cualquier fuente del líquido refrigerante donde la presión del agua está libre.
 - Nunca introduce anticongelante ni algún solvente orgánico en cualquier parte del instrumento. Los solventes orgánicos causarán daño irreparable a la unidad!
 - No opera con temperaturas de búfer encima del máximo especificó especificaciones técnicas. Recalentar causará daño irreparable a la unidad!

Viktig Information – Swedish

- om denna utrustning används i ett sätt som inte har specificeras av Hoefler, Inc. skyddet tillhåll vid utrustningen kan skadas.
- Detta instrument formges för inomhuslaboratorium användning bara.
- Bara medhjälpare och delar godkände eller levererade vid Hoefler, Inc. kan användas för fungera, underhålla, och servicing denna produkt.
- använder bara en kraft tillgång som är CE markerade eller säkerhet intygade vid en nationellt erkänd testande laboratorium.
- Säkerheten locket måste vara på platsen före koppla kraften tillgången blyen till en kraft tillgång.
- Vänder sig alla kraft tillgång kontroller av och kopplar bort kraften blyen före flytta säkerheten locket.
- Cirkulerar bara vatten eller 50/50 vatten/ethylene glycol genom värmen exchanger i så utrustad fall. Inte kopplar värmen exchanger till en vatten kran eller något kylmedel källa där vattnet trycket är

unregulated.

- Inför aldrig kylvätska eller något organiska lösningsmedel in i någon del av instrumentet. Organiskt lösningsmedel ska orsaka irreparable skada till enheten!
- Använd inte med buffert temperaturer över det högsta angivna tekniska specifikationerna. Överhettning skulle orsaka irreparabla skador på enheten!

Waste Electrical and Electronic Equipment (WEEE)

English



This symbol indicates that the waste of electrical and electronic equipment must not be disposed as unsorted municipal waste and must be collected separately. Please contact an authorized representative of the manufacturer for information concerning the decommissioning of your equipment.

French



Ce symbole indique que les déchets relatifs à l'équipement électrique et électronique ne doivent pas être jetés comme les ordures ménagères non-triées et doivent être collectés séparément. Contactez un représentant agréé du fabricant pour obtenir des informations sur la mise au rebut de votre équipement.

German



Dieses Symbol kennzeichnet elektrische und elektronische Geräte, die nicht mit dem gewöhnlichen, unsortierten Hausmüll entsorgt werden dürfen, sondern separat behandelt werden müssen. Bitte nehmen Sie Kontakt mit einem autorisierten Beauftragten des Herstellers auf, um Informationen hinsichtlich der Entsorgung Ihres Gerätes zu erhalten.

Italian



Questo simbolo indica che i rifiuti derivanti da apparecchiature elettriche ed elettroniche non devono essere smaltiti come rifiuti municipali indifferenziati e devono invece essere raccolti separatamente. Per informazioni relative alle modalità di smantellamento delle apparecchiature fuori uso, contattare un rappresentante autorizzato del fabbricante.

Spanish



Este símbolo indica que el equipo eléctrico y electrónico no debe tirarse con los desechos domésticos y debe tratarse por separado. Contacte con el representante local del fabricante para obtener más información sobre la forma de desechar el equipo.

Swedish



Denna symbol anger att elektriska och elektroniska utrustningar inte får avyttras som osorterat hushållsavfall och måste samlas in separat. Var god kontakta en auktoriserad tillverkarrepresentant för information angående avyttring av utrustningen.

Transfer Electrophoresis Unit function and description

The Hoefer® TE42 and TE62 transfer units rapidly transfer proteins, DNA, or RNA from up to four polyacrylamide or agarose gels onto a membrane. Gels and membranes are assembled into a cassette and submerged in a tank filled with transfer buffer. The electrodes in the tank are connected to an external power supply.

The TE62 contains a heat exchanger in the base. Buffer is separated from the coolant by a heat-conducting alumina plate. The TE42 is not equipped with a buffer cooling system. If cooling is required, an immersible heat exchanger can be ordered separately.

Transphor models and features

	built-in heat exchanger for cooling	compatible with external power supply
TE42		✓
TE62	✓	✓

Unpacking

Unwrap all packages carefully and compare contents with the packing list or ordering information, making sure all items arrived. If any part is missing, contact Hoefer, Inc. Inspect all components for damage that may have occurred while the unit was in transit. If any part appears damaged, contact the carrier immediately. Be sure to keep all packing material for damage claims or for repacking should it become necessary to return the unit.



This declaration of conformity is only valid for the instrument when it is:

- used in laboratory locations,
- used as delivered from Hoefer, Inc. except for alterations described in the User Manual, and
- connected to other CE labeled instruments or products recommended or approved by Hoefer, Inc.

Specifications

All tank models: TE42 and TE62

Gel size	up to four 15×21 cm gels or up to sixteen 7×10 cm mini-gels
Max. wattage	200 W
Max. voltage	100 V
Max. amperage	2 A
Max. temperature	45 °C
Buffer required	4–5 liters, depending on the number of cassettes in place
Environmental operating conditions	Indoor use: 4–40 °C Humidity up to 80% Altitude up to 2000 m Installation category II Pollution degree 2
Dimensions (w × d × h)	TE42: 28 × 13 × 30.5 cm (11 × 5.1 × 12 in.) TE62: 28 × 16.5 × 32 cm (11 × 6.5 × 12.5 in.)
Product certifications	EN61010–1, UL3101–1, CSA C22.2 1010.1, CE



Fig 1. Transphor main components.

Included but not shown:

TE42:

- Gel Cassettes (2)
- Foam sponges, 6 mm thick (2)
- Foam sponges, 3 mm thick (4)
- Blotting paper, sheets (25)

TE62:

- Gel Cassettes (4)
- Foam sponges, 6 mm thick (4)
- Foam sponges, 3 mm thick (8)
- Blotting paper, sheets (25)

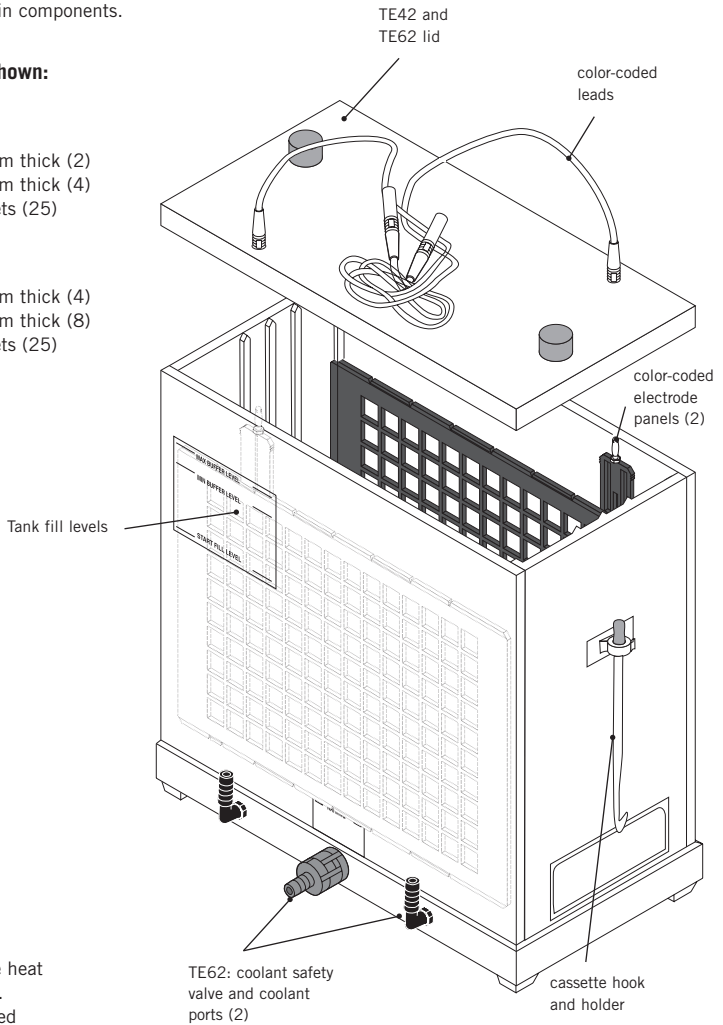

Note: An immersible heat exchanger (Code no. TE47) can be ordered separately for the TE42.

Operating instructions

Perform the transfer as soon as possible after electrophoresis to minimize band sample diffusion. Each step is described below.

Prepare the buffer

Prepare a minimum of 5 liters of the appropriate transfer buffer. Chill before use if possible.

Prepare the unit

①

Rinse the transfer tank and cassettes with distilled water.

②

Active cooling is optional but strongly recommended. If no active cooling will be used, go to step 3.

Note: Connect the heat exchanger to a circulator bath such as the RCB20-PLUS.

Circulate only water or 50/50 water/ethylene glycol to prevent damage to the unit.

The circulator pump must not generate a pressure greater than 0.7 bar (10 psi) above atmospheric pressure.

Set the temperature to 10 °C or higher if circulating only water. If using 50/50 ethylene glycol/water, the temperature can be set lower.

Start the circulator bath at the same time as the transfer.

Note: Refer to the Electrotransfer Notes section for a discussion of membranes and buffers.

Note: For quick and easy connections, install Quick-fit coupler fittings with valves in the line.

Note: The relief valve opens if the pressure in the heat exchanger exceeds 0.7 bar (10 psi) above atmospheric pressure.

Note: For quick and easy connections, install Quick-disconnect fittings with valves.

Note: Even if no cooling is required for your system, the buffer should be circulated with a stirrer to avoid buffer depletion at the electrodes.

TE42

Lower the heat exchanger (ordered separately, or use the heat exchanger supplied with the Hoefer SE600 Gel Electrophoresis Unit if you have one) into the lower chamber, fitting the ports into the notches in the rim. Prepare two lengths of 10–12 mm i.d. (3/8–1/2") vinyl or silicone tubing for the cooling circuit and skip to "Attach tubing" below.

TE62

First attach tubing to the red pressure relief valve between the water inlet and outlet ports and insert the free end into the bath or other container or drain to catch any pressure relief overflow. Prepare two lengths of 9 mm (3/8") vinyl or silicone tubing and see "Attach tubing" below for instructions on fitting it to the ports of the heat exchanger in the base of the unit.

Attach tubing

Slide hose clamps (4 total) onto each end of two lengths of tubing. Attach one end of each length of tubing to a heat exchanger port. Attach the free ends of each length of tubing to the circulator bath ports; one to the inlet and the other to the outlet. Secure the connections with the hose clamps.

3

Place (**do not drop**) a magnetic stirring bar in the buffer tank. (Dropping objects onto the alumina plate in the TE62 may cause the plate to crack.) Set the unit onto a magnetic stirrer. Fill transfer buffer to the "Start fill level" line. (This requires approximately 3.8 liters.) Set the stirrer to low-medium, which creates buffer circulation without forcing buffer through assembled cassettes.

Note: Always wear gloves when handling membranes to avoid getting fingerprints on them.

Important! Take great care in removing all air bubbles at each step because the presence of air bubbles, especially between the membrane and gel, blocks transfer.

Assemble the transfer cassette

1

Pre-wet nitrocellulose or nylon membranes with distilled water. Pre-wet PVDF or other hydrophobic membranes in methanol. Then soak all membrane types in transfer buffer for 2–5 minutes.

2

Open the cassette by releasing both latch tabs along the edge opposite the hinges. Place the opened cassette into a tray filled with at least 3 cm of transfer buffer.

3

Assemble the transfer stack so that molecules will migrate toward the membrane. For negatively charged macromolecules (such as nucleic acids and most proteins), build the stack on the grey half of the cassette (and then later position the assembled cassette in the tank so that this side faces the grey anode (+) panel, which connects to the red lead):

Place one 3 mm-thick sponge on the opened submerged cassette and press gently until all air is expelled. Place one sheet of blotting paper on the sponge, and then place the membrane on the blotting paper. Place the gel—which contains a sample that has been electrophoretically separated and equilibrated (if required) with transfer buffer—on the membrane. Gently roll a glass pipet or test tube over the gel to expel trapped air between the membrane and gel. Cover the gel with a sheet of blotting paper and then place a sponge of the proper thickness (see diagram on next page), again pressing gently to expel trapped air.

4

Close the cassette and press lightly to lock the tabs. The assembled cassette should hold the gel in firm contact with the membrane without squeezing the gel. If the stack seems loose, add sheets of blotting paper; if the stack seems tight, replace the top sponge (above the gel) with a sheet of blotting paper. If you remove the bottom sponge (below the membrane), substitute at least two sheets of blotting paper to create space between the membrane and the cassette panel.

Fig 2. Transfer stack assembly. The stack is oriented so that negatively charged molecules migrate toward the grey anode (+).

Important! Do not overstuff the cassette.

Note: Try to place the gel correctly the first time because proteins may begin to transfer immediately; once transfer has begun, moving the gel will distort results or cause "shadow bands" on the blot.

The cassette panels are color coded:
black (top) = cathode side grey
(bottom) = anode side

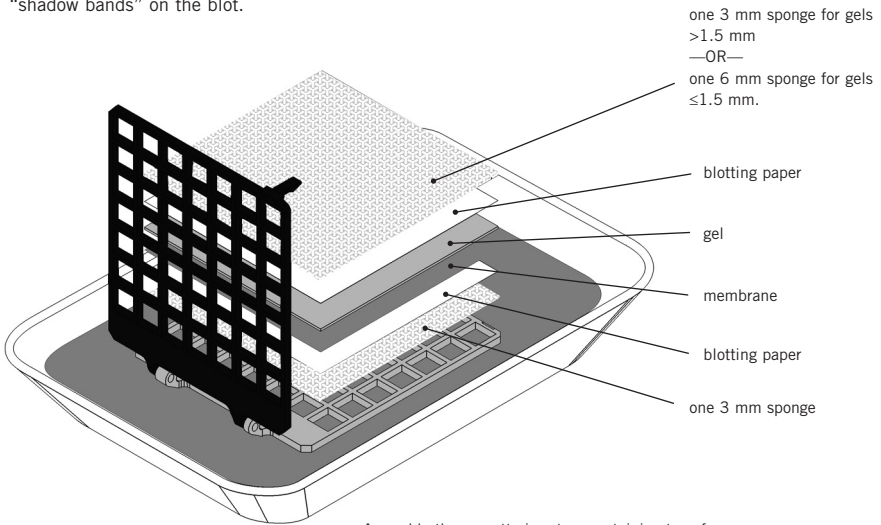

Assemble the cassette in a tray containing transfer buffer about 3 cm deep.



Install the cassette(s)

1

The tank holds up to four cassettes; if transferring only one or two gels, use the cassette positions nearest the center. (The submersible heat exchanger, if used in the TE42, fills the two center slots, so only two cassettes can be placed in the outside slots.)

The cassettes must be oriented so that the hinges face up and so that *the black side of each cassette faces the black cathode panel.*

Work quickly when moving the assembled cassette(s) to the tank to avoid draining the sponges: Place the tray holding the cassette(s) near the tank, lift out one cassette at a time, and slide it into a set of vertical slots. Do not discard the buffer in the tray.

2

Once in place, tap each cassette lightly until most air bubbles are dislodged. (A few small bubbles in the sponges are unlikely to interfere with the transfer.)

3

Inspect the buffer level. Add or remove buffer as required so that the level falls between the minimum and maximum buffer level lines. (Buffer above the maximum buffer level line may cause corrosion of the electrical contacts.)

Transfer

Take care in orienting all system components so that the electric field applied causes all species to migrate toward the membrane. The migration direction depends on both the characteristics of the sample and the pH of the transfer buffer. If the species of interest is negatively charged in the transfer buffer and the stack is assembled so that the membrane is nearest the grey side of the cassette, then this side faces the anode (+). Most proteins migrate toward the anode in the Towbin Tris/glycine/methanol buffer system (independent of the presence of SDS), and under most conditions nucleic acids are negatively charged and also migrate toward the anode.

Important! Never allow the buffer temperature to exceed 45 °C. Excessive heat will cause the unit to warp.

Cooling is strongly recommended. Any setting that results in higher than 5 W of power will generate enough heat to require active heat control. A refrigerated circulator bath should be set to cool to about 10 °C. (If using 50/50 ethylene glycol/water, the temperature can be set lower.) Chill buffer before use if possible.

Recommended power settings. Most transfers are complete within one hour, but larger molecules or thicker gels may require longer transfer times; the optimum transfer time for each system must be determined empirically. Transfers left to run overnight should be set to a constant current setting no higher than 0.1 A.

Typical transfer parameters

Parameters for your sample and buffer system must be determined empirically.

	protein	nucleic acids
Buffer	Towbin	1X TBE or 1X TAE
Current (A)	0.8–1.0	0.9–1.0
Voltage (V)	70–80	50
Transfer time	~1 hour	~1 hour
Coolant temp.	10 °C	10 °C or less



TE42 and TE62

1

Install the safety lid

The cassettes and electrode panels are color coded to match the leads in the lid: Orient the lid so that the grey half of the cassettes and the grey anode panel face the anode (+), or red lead, and the black half of the cassettes and the black cathode panel face the cathode (-), or black lead.

2

Use only an approved power supply such as the Hoefer PS2A200, PS200HC, or PS300B. Make sure the power supply is off and all controls are set to zero. Plug the red lead into the red output jack and the black lead into the black output jack. In most systems, the red lead is the anode (+), and the black lead is the cathode (-).

3

Set the power supply

Constant current mode is recommended. If constant voltage mode is selected, carefully monitor the current (increased current increases Joule heating). If the current exceeds 1 A, decrease the voltage. If available, set the power supply timer for no more than two hours.

Note: The two red caps on the lid accommodate the banana plugs on the SE600 model immersible heat exchanger (irrespective of the orientation).



Note: It is a good idea to stain the gel to determine the completeness of the transfer.

Note: Do not store used buffer with transfer tank. Chill buffer to 10 °C before reuse.

After the transfer is complete

1

Turn the voltage and current settings to zero and turn off the power supply. Disconnect the leads from the power supply jacks.

2

Lift off the lid. Use the plastic hook (stored in the holder at the side of the unit) to lift up a cassette just far enough to be able to grab it and place it into a tray.

3

Open each cassette carefully and remove the gels and membranes. Label each membrane and indicate the sample side. Lift membrane(s) with blunt forceps and air dry, or follow the instructions of your protocol.

4

Discard the blotting paper, but reuse the sponges.

5

Rinse the unit immediately after use. (See the Care and maintenance section on the next page.)



*Use $\leq 20\%$ methanol (methyl alcohol) in transfer buffers is the only exception.

Care and maintenance

Cleaning

- Do not autoclave or heat any part above 45 °C.
- Do not expose to alcohols or organic solvents!*
- Never use abrasive detergents.
- If using radioactive reagents, decontaminate the unit with a cleaning agent such as Contrad 70™ or Decon 90™.

Rinse the tank, cassettes, and sponges with distilled water immediately after each use. Allow the unit to air dry completely. Periodically wash with a dilute solution of a mild detergent.

When cleaning the unit, leave the electrode panels in place. If they must be switched (not recommended), take great care to not stretch or break the platinum wire: carefully pull the panel forward far enough to clear the retaining lip (<5 mm). With one hand grab the banana plug support (not the banana plug) and with the other hand grab the panel at a point well away from the wire. Lift the panel out.

Mains power module

Fig 3. The mains power module is located on the back panel.

Important! Fuses protect equipment by disconnecting loads too large for the instrument's circuit design, so it is imperative that fuses are replaced only with fuses of identical rating. The mains power module, located at the back of the power lid, contains two input fuses:

115 V~ model:
T 3A 250 V, 5 × 20 mm

230 V~ model:
T 1.6A 250 V, 5 × 20 mm

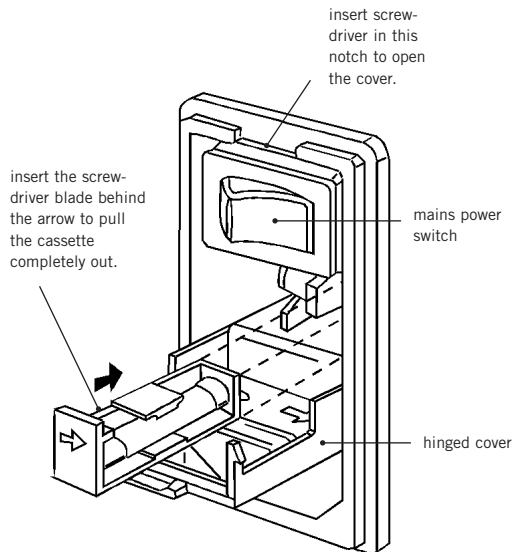

1

Caution: Turn the mains power supply switch off and detach the power cord before replacing input fuses!

2

Open the fuse compartment by inserting a small flat-blade screwdriver into the slot at the top of the power module. Twist the screwdriver 1/8 turn to release the cover, then pull out the hinged compartment, which opens out.

3

Insert the screwdriver above the arrow on one fuse cassette, catch the cassette end, and slowly slide it completely out of the module.

4

Pull the fuse out of its cassette and inspect. If the fuse element is burned or broken, replace the fuse with an identical type. If the fuse appears to be intact, check it with a multi-meter. (A reading of 1Ω or less indicates the fuse is still usable.)

5

After placing a good fuse into the cassette, slide it into the power module, making sure the arrow on the cassette points to the right (in the same direction as the guide arrows on the inside of the compartment door).

6

Repeat steps 3 to 5 for second cassette.

7

Close the fuse compartment cover and gently press it into the power module until it snaps shut.

8

Plug the power cord into the unit and turn the mains power switch on.

Troubleshooting

problem

solution

Incomplete transfer

Blank areas on the membrane

Remove all trapped air pockets in the transfer stack assembly: assemble the stack while it is submerged in transfer buffer, gently press on each sponge as it is added to the stack, and roll a glass pipette or test tube over the membrane and gel to eliminate all air bubbles.

Reduce the stirring speed to prevent turbulence.

Process only one strip or membrane in each tray or cassette to prevent overlapping.

Use buffer with a lower ionic strength.

Check electrode continuity. During the transfer, a continuous stream of gas is released along the entire length of the electrodes. If bubbles do not form along the entire length of the electrode, replace the electrode.

If cassettes are bowed when empty, replace. Overpacking the cassette causes it to bow; see the recommended assembly instructions on page 6.

Grid pattern on membrane

Add extra sheets of blotting paper to increase the clearance between the cassette panel and the gel. Take care not to overstuff the cassette; the gel should be held firmly and evenly between the sponges, but not so tightly that it is squeezed.

Molecules do not migrate out of gel

Increase the field strength.

Increase transfer period. (Try doubling it.)

Do not use staining or fixing agents on the gel before transfer.

Use a thinner gel.

Reduce the gel acrylamide concentration.

Check that the buffer pH is close to the intended pH. Most buffers should not be titrated; make fresh buffer.

Use 3.5 mM SDS (0.1%) in the transfer buffer.

Avoid including methanol in the transfer buffer or reduce the amount to the absolute minimum.

Use reagent-grade chemicals.

Increase the length of time Southern blots are depurinated.

Increase the net charge on the protein by changing to a transfer buffer with a different pH. Lower pH (<6–7) increases the positive charge on proteins; higher pH (>6–7) increases the negative charge on proteins.

problem**solution**

Diffuse band patterns

Transfer immediately after electrophoretic separation. If equilibrating before the transfer, shorten or eliminate the equilibration time or move the gel to the cold room during equilibration.

If transfer buffer contains methanol ($\geq 10\%$), equilibrate the gel in transfer buffer for 30 minutes to allow it to shrink before assembling the stack. *Note:* Because methanol causes the gel to shrink slightly, large molecules may migrate more slowly.

Take care that the gel is held firmly against the membrane and that it does not shift once contact is made.

If excess heating occurs during the transfer, lower the temperature of the cooling fluid in the heat exchanger.

Check that the preferred binding surface of the membrane (if any) contacts the gel.

Inefficient binding to membrane*Chemical parameters*

Fix or crosslink the molecule onto the membrane according to the requirements of the nucleic acid, protein, or membrane type.

Prepare protein transfer buffer *without* SDS.

Verify the optimal amount of methanol required for the membrane type and check the buffer solution. Add 10–20% methanol to the transfer buffer to enhance binding to nitrocellulose.

Membrane parameters

Wear gloves when handling membranes.

Store membranes at ambient temperature out of direct sunlight to keep the membranes activated.

Use a membrane with a smaller pore size (0.10–0.20 μm) if proteins pass through the membrane, or use a different membrane type.

Place a membrane both over and under the gel if you suspect one protein is moving in the opposite direction from the majority of the proteins. Check both membranes for protein(s).

Check if too much sample is available for the binding surface area by applying two membranes instead of one. If “blow through” occurs, reduce the sample load.

For more troubleshooting hints, refer to Bjerrum, O.J. *et al.* (1988).

Electrotransfer notes

Electrophoretic transfer advantages

Electrophoretic transfer of proteins and nucleic acids is much faster than the blotting methods first described by Southern for DNA, Alwine *et al.* for RNA, or Renart *et al.* for proteins. The tank transfer method uses high current to reduce the transfer time of most samples to 45–60 minutes.

Electrophoretic transfer can improve transfer efficiency over non-electrophoretic blotting, especially for proteins, but no quantitative transfer technique has yet been developed due to the complexity of the reactions. Quantitative recovery is actually not required for most purposes because binding macromolecules to a membrane increases the sensitivity of detection methods such as autoradiography and permits detection of specific proteins by antibodies or affinity labels, and of specific nucleic acids by hybridization with complementary strands of RNA or DNA.

The buffer can be chosen to result in a transfer toward either the cathode or the anode. The buffer pH must be such that all species of interest are charged and migrate in the same direction. The ionic strength should not be too high, since this will produce excessive current and heat. For this reason, the high salt conditions used by Southern for capillary blotting of DNA cannot be used. The most widely used buffer systems are those of Towbin *et al.* for transferring proteins, and of Bittner *et al.* for transferring nucleic acids. Buffer systems for transfer of each type of sample are listed later in this section.

Factors affecting the transfer

Parameters such as sample characteristics, membrane type, gel pore size, and the transfer buffer used all contribute to the transferability of macromolecules, and should be kept in mind when developing a protocol. Very small molecular species, for instance, migrate quickly but often do not bind as well as larger molecules; large molecules bind more efficiently but do not elute from the gel as rapidly. The rate of elution is also affected by the pore size of the gel and the orientation of the molecules.

Further, the degree to which molecules bind to the membrane is influenced by membrane characteristics such as pore size and type, and buffer characteristics such as pH, salt type and concentration, and the presence of detergents such as sodium dodecyl sulfate (SDS). Conditions required for efficient elution may not coincide with optimal conditions for binding. To find the optimum conditions for transferring your sample, balance these effects: If the sample elution rate is slow, a longer transfer period may be required. (In our experience, low voltage transfers for longer periods do not offer much improvement.) If sample binding is inadequate, try different buffer conditions. For a comprehensive review, see Gershoni and Palade (1983).

If the transfer buffer system is different from the electrophoresis buffer system, the gel should be equilibrated with the transfer buffer before the transfer to ensure swelling or shrinking occurs before the gel contacts the transfer membrane. If this step is skipped, band distortion or loss of resolution could result.

Instrument guidelines

Cooling

Considerable Joule heat is generated during any transfer because of the high current employed, **so active cooling is recommended**, especially for transfers requiring more than one hour, protein transfers where biological activity must be retained, or transfer of nucleic acids. (The high conductivity of the phosphate buffer used by Bittner *et al.* (1980) leads to a relatively rapid temperature rise.) Buffer temperature should not exceed 45 °C because the cassettes and electrode supports may warp. Use a circulator bath set to 10 °C if using water as a coolant. (You can use a lower setting if the coolant is 50/50 ethylene glycol/water.) Never leave the unit unattended for more than one hour under high power conditions (>0.5 A).

Power setting

If using a power supply that can be set to either constant current or constant voltage mode, we recommend that it be set to operate in constant current mode. Buffer conductivity increases with temperature. During blotting in an uncooled chamber, Joule heating and rising conductivity may result in dangerous overheating if the power supply is set to maintain constant voltage. If a constant voltage power supply must be used, monitor and adjust the voltage to maintain a current at or below 1 A.

Protein transfers

Study summaries

Gershoni and Palade (1982) investigated factors affecting protein recovery from SDS gels to nitrocellulose or DBM paper. According to their findings, methanol in the Towbin buffer system is necessary to achieve efficient binding to nitrocellulose. Methanol improves binding in part by removing protein-bound SDS. In the absence of methanol, labeled bovine serum albumin (BSA) passes through at least five layers of membranes. Methanol may cause a gel to shrink, however, so the elution rate decreases. By using a cationic membrane (such as nylon), which binds the proteins more efficiently, and omitting methanol from the transfer buffer, Gershoni and Palade obtained a much more quantitative transfer. The disadvantage of cationic membrane is that protein stains also bind well, so that the staining background tends to be very high. Properly quenched, however, this paper can be used for antibody detection or other overlay methods of protein identification. A summary of membrane type and recommended methanol concentration follows:

membrane type	methanol %
Charged nylon	0
Nitrocellulose	≤ 20
PVDF	≤ 15

Some workers have reported to us that a low concentration of SDS (0.1%) improves the transfer of protein from an SDS gel. Burnette (1981) and Symington *et al.* (1981) investigated the effect of the molecular weight of protein. Gibson (1981) describes a method to increase the extent of transfer of large proteins by limited cleavage with pronase during transfer.

Protein transfer buffers

Use a buffer with low ionic strength, such as the two listed below, to prevent overheating. Use the alternate CAPS buffer when Tris cannot be used, as in peptide sequencing. CAPS can improve transfer because of its effect on the charge of the protein (see Matsudaira, 1987). For native proteins, we suggest using the electrophoresis buffer for transfer as well. Use the Towbin buffer to transfer SDS-denatured proteins toward the anode.

Towbin buffer

(25 mM Tris, 192 mM glycine, 20% v/v methanol, pH 8.3, 6 liters)

Tris (FW 121.1)	25 mM	18.2 g
Glycine (FW 75.07)	192 mM	86.5 g
SDS ^a (FW 288.4)	0.1% (3.5 mM)	6.0 g

Dissolve in 4 liters distilled water. Add methanol as required^b.

Bring to 6 liters with distilled water. Do not adjust the pH, which should be between 8.2 and 8.4.

Optional: Chill before use.

^aOptional: Adding SDS can improve transfer efficiency.

^bDepending on the membrane type selected, adding methanol can improve the transfer results (see discussion and table above). Because buffers containing methanol may deteriorate if stored for long periods, add methanol as required just prior to transfer.

CAPS buffer, 1X

(10 mM CAPS, pH 11.0, 5 liters)

CAPS (FW 221.3)	10 mM	11.1 g
[3-(cyclohexylamino)-1-propanesulfonic acid]		

Dissolve in 4.5 liters distilled water, adjust to pH 11.0 with conc. NaOH. Adjust volume to 5.0 liters.

Nucleic acid transfers

Nucleic acids must normally be transferred in denatured form for most efficient binding. RNA is normally denatured with glyoxal before separation or separated in denaturing gels containing formaldehyde or methyl mercury. However, double stranded DNA is usually denatured in the gel with NaOH. The alkali must be neutralized and the gel equilibrated in transfer buffer before electrotransfer. For both DNA and RNA gels, any SDS must also be removed to assure efficient binding. Bittner *et al.* (1980) wash gels three times, 20 minutes each, to assure complete removal of denaturants and detergents.

See Bittner *et al.* for a study of the transfer efficiency for DNA of different sizes. The Bittner transfer buffer contains 25 mM sodium phosphate, pH 6.5. Also described is a method for the introduction of nicks by limited nuclease action in order to facilitate transfer of larger DNA fragments.

Recommended DNA buffers include the Bittner sodium phosphate buffer (see reference) and TBE. For RNA, TAE is recommended. TBE and TAE stock recipes are listed below. These buffers are most often diluted to 1X, but the concentration can range down to 0.1X. Cooling is strongly recommended for these buffers, especially at higher concentrations.

EDTA solution^a

(0.5 M EDTA, pH 8.0, 100 ml)

Na ₂ EDTA·2H ₂ O (FW 372.2)	0.5 M	18.6 g
---	-------	--------

Dissolve in 70 ml distilled water. Adjust to pH 8.0 with 10 M NaOH (approx. 5 ml), then add distilled water to 100 ml.

DNA transfer buffer, 10X

(10X Tris-borate-EDTA (TBE)^a, pH ~8.2, 1 liter)

Tris (FW 121.1)	900 mM	109.0 g
Boric acid (FW 61.83)	900 mM	55.6 g
EDTA solution (0.5 M, pH 8.0)	20 mM	40.0 ml

Distilled water to 1.0 liter. Do not adjust pH.

Dilute to 1X before use to yield 90 mM Tris, 90 mM boric acid, and 2 mM EDTA.

This dilution is commonly used, but dilutions down to 0.1X may be used should it be necessary to decrease the amount of current in the system in order to control overheating.

RNA transfer buffer, 10X

(10X Tris-acetate-EDTA (TAE)^b, pH ~8.4, 1 liter)

Tris (FW 121.1)	400 mM	48.4 g
Acetic acid, glacial (~17.4 M)	~200 mM	11.4 ml
EDTA solution (0.5 M, pH 8.0)	10 mM	20.0 ml

Distilled water to 1.0 liter. Do not adjust pH.

Dilute to 1X before use to yield 40 mM Tris, ~20 mM acetate, and 1 mM EDTA.

This dilution is commonly used, but dilutions down to 0.1X may be used should it be necessary to decrease the amount of current in the system in order to control overheating.

^aCurrent Protocols in Molecular Biology (1993), A.2.1.

^bSambrook, J., and Russell, D.W. (2001) Molecular Cloning: A Laboratory Manual, A1.17.

Bibliography

- Alwine, J.C., Kemp, D.J., and Stark G.R., Method for detection of specific RNAs in agarose gels by transfer to DBM paper and hybridization with DNA probes. *Proc. Natl. Acad. Sci. USA.* **74**, 5350–5354 (1977).
- Bittner, M., Kupferer, P., and Morris, C.F., Electrophoretic transfer of proteins and nucleic acids from slab gels to diazobenzyloxymethyl cellulose or nitrocellulose sheets. *Anal. Biochem.* **102**, 459–471 (1980).
- Bjerrum, O.J., Larsen, K., and Heegaard, N., *CRC Handbook of Immunoblotting of Proteins* Vol. 1, Section 7. CRC Press (1988).
- Burnette, W.N., Western blotting electrophoretic transfer of proteins from sodium dodecyl sulfate-polyacrylamide gels to unmodified nitrocellulose and radiographic detection with antibody and radioiodinated protein A. *Anal. Biochem.* **112**, 195 (1981).
- Gallagher, S., Winston, S.E., Fuller, S.A. and Hurrell, J.G.R., Immunoblotting and Immunodetection. In *Current Protocols in Molecular Biology*. 10.8.1–10.8.17. Greene Publishing and Wiley-Interscience, NY (1993).
- Gershoni, J.M., Davis, F.E. and Palade, G.E. Protein blotting in uniform or gradient electric fields. *Anal. Biochem.* **144**, 32–40 (1985).
- Gershoni, J.M., and Palade, G.E. Electrophoretic transfer of proteins from sodium dodecyl sulfate-polyacrylamide gels to a positively charged membrane filter. *Anal. Biochem.* **124**, 396–405 (1982).
- Gershoni, J.M., and Palade, G.E. Protein Blotting: Principles and Applications. *Anal. Biochem.* **131**, 1–15 (1983).
- Gibson, W. Protease-facilitated transfer of high molecular weight proteins during electrotransfer to nitrocellulose. *Anal. Biochem.* **118**, 1 (1981).

- Lin, W., and Kasamatsu, H., On the electrotransfer of polypeptides from gels to nitrocellulose membranes. *Anal. Biochem.* **128**, 302–311 (1983).
- Matsudaira, P. Sequence from Picomole Quantities of Proteins Electroblotted onto Polyvinylidene Difluoride Membranes. *J. Biol Chem.* **262**, 10035 (1987).
- Ohmsted, J.B., Affinity purification of antibodies from diazotized paper blots of heterogeneous protein samples. *J. Biol. Chem.* **256**, 11955 (1981).
- Renart, Reiser, J. and Stark, G.R. Transfer of proteins from gels to DBM paper and detection with antisera: a method for studying antibody specificity and structure. *Proc. Natl. Acad. Sci. USA* **76**, 3116 (1979).
- Sambrook, J., and Russell, D.W. *Molecular Cloning: A Laboratory Manual*, Cold Spring Harbor Laboratory Press, A1.17 (2001).
- Southern, E.M. Detection of specific sequences among DNA fragments separated by gel electrophoresis. *J. Molec. Biol.* **98** (3):503–517 (1975).
- Stellway, E.J., and Dahlberg, A.E. Electrophoretic transfer of DNA, RNA, and protein onto DBM paper. *Nucleic Acids Res.* **8**, 299 (1980).
- Symington, J., Green, M., and Brackmann, K., Immunological detection of proteins after electrophoretic transfer from gels to diazo paper: analysis of adenovirus encoded proteins. *Proc. Natl. Acad. Sci. USA* **78**, 177–181 (1981).
- Towbin, H., Staehelin, T., and Gordon, J., Electrophoretic transfer of proteins from polyacrylamide gels to nitrocellulose sheets: procedure and some applications. *Proc. Natl. Acad. Sci. USA.* **76**, 4350–4354 (1979).

Ordering information

product	quantity	code no.
TE42 Transfer Electrophoresis Unit. Includes safety lid with power cables, 2 gel cassettes, 4 foam sponges 3-mm thick, 2 foam sponges 6-mm thick, 25 sheets of blotter paper.	1	TE42
TE62 Cooled Transfer Electrophoresis Unit. Includes safety lid with power cables, 4 gel cassettes, 8 foam sponges 3-mm thick, 4 foam sponges 6-mm thick, 25 sheets of blotter paper.	1	TE62

Accessories and replacement parts

Glass heat exchanger for TE42	1	TE47
Electrode panel, black	1	TE43BK
Electrode panel, grey	1	TE43GY
Gel cassette, 2 foam sponges 3-mm thick, 1 foam sponge 6-mm thick.	1	TE44H
Lower buffer tank for TE42	1	TE56
Lower buffer tank with heat exchanger for TE62	1	TE67
Sponges, Dacron, 6-mm thick.	2	TE45
Sponges, foam, 6-mm thick.	4	TE45F
Sponges, foam, 3-mm thick.	4	TE45F-1/8
Lid with cables for TE42 or TE62.	1	TE49
High voltage leads	1	SE6056-HV
Quick-fit coupler body, female, to fit 9.5 mm (3/8") ID tubing	2	QF3/8
Quick-fit coupler body, male, to fit 9.5 mm (3/8") ID tubing	2	QFX3/8

Blotter paper

Blotter paper, sheets, 9 × 10.5 cm	50	TE26
Blotter paper, sheets, 14.5 × 21.5 cm	50	TE46

Companion products

Hoefler PS2A200 Power Supply, 200 V, 2A	1	PS2A200
Hoefler PS200HC Power Supply, 200 V, 2A	1	PS200HC
Hoefler PS300B Power Supply, 300 V, 0.5A	1	PS300B



Hoefer, Inc.

32 Scotland Blvd, Ste. 9,
Bridgewater, MA02324, USA

Toll Free: 1-800-813-0488

Phone: 1-508-807-4665

E-mail: support@hoeferinc.com

Web: www.hoeferinc.com

Hoefer is a registered trademark
of Hoefer, Inc.

© 2023 Hoefer, Inc.

— All rights reserved.

