

Hoefer SE600/SE660

Standard Dual Cooled Gel Electrophoresis Units

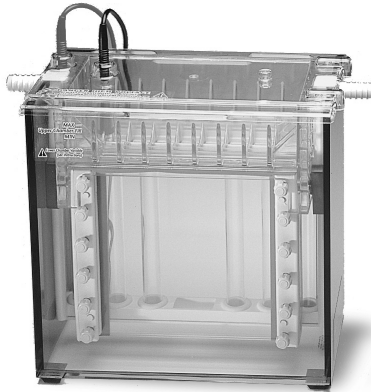

Contents

Important Information	ii
Waste Electrical and Electronic Equipment (WEEE)	vii
Gel Electrophoresis Unit Function and Description	1
Specifications	2
Unpacking and Inventory.....	4
Operating Instructions.....	7
Prepare the gel sandwich.....	7
Acrylamide Gels.....	11
Gradient Gels	13
Sample Preparation and Loading.....	15
Final Assembly	17
Separating the Sample	22
Care and Maintenance	25
Troubleshooting	26
Bibliography.....	30
Ordering Information.....	33

Important Information – English

- If this equipment is used in a manner not specified by Hoefer, Inc. the protection provided by the equipment may be impaired.
- This instrument is designed for indoor laboratory use only.
- Only accessories and parts approved or supplied by Hoefer, Inc. may be used for operating, maintaining, and servicing this product.
- Only use a power supply that is CE marked or safety certified by a nationally recognized testing laboratory.
- The safety lid must be in place before connecting the power supply leads to a power supply.
- Turn all power supply controls off and disconnect the power leads before removing the safety lid.
- Circulate only water or 50/50 water/ethylene glycol through the heat exchanger if so equipped. Do not connect the heat exchanger to a water tap or any coolant source where the water pressure is unregulated.
- Never introduce antifreeze or any organic solvent into any part of the instrument. Organic solvents will cause irreparable damage to the unit!
- Do not operate with buffer temperatures above the maximum specified technical specifications. Overheating will cause irreparable damage to the unit!

Důležité Informace – Czech

- Pokud by toto zařízení je použito způsobem, který není podle Hoefer, Inc. ochrana poskytovaná na základě zařízení může být narušena.
- Tento nástroj je určen pro vnitřní použití v laboratoři pouze.
- Pouze příslušenství a části schválené, nebo poskytnuté Hoefer, Inc. mohou být použity pro provoz, údržbu, a údržbě tohoto výrobku.
- zdroj napájení používají jen že je opatřen označením CE osvědčena nebo bezpečnost vnitrostátně uznanými zkušebními laboratoři.
- Bezpečnosti lid musí být zavedena před připojením napájecí zdroj napájení vede k.
- Turn veškeré napájení kontroly vypnuto a odpojit

před odběrem energie vede bezpečnostní víko.

- Rozeslat pouze voda nebo 50/50 voda/ ethylenglykolu prostřednictvím výměník tepla je li to vybavena. Nemají připojení výměník tepla s vodními setřepná nebo jakékoli chladicí kapaliny zdroje, kde tlak vody je neregulo.
- Nikdy zavést prostředek proti zamrznutí nebo jakákoli organická rozpouštědla do jakékoli části z tohoto nástroje. Rozpuštělům způsobí nenapravitelné poškození jednotka!
- Nejsou provozována s pufru teplotách nad maximální stanovenou technickými specifikacemi. Přehřátí způsobí nenapravitelné poškození jednotka!

Vigtig Information – Danish

- Hvis dette udstyr bruges i en måde ikke specificeret ved Hoefer, Inc. den beskyttelse, som er blevet forsynet af udstyret kan måske svækkes.
- Dette instrument er designet for indendørs laboratoriumbrug bare.
- Bare tilbehør og del godkendede eller forsynede ved Hoefer, Inc. kan måske bruges for drive, funktionsfejl, og betjening dette produkt.
- bruger Bare en strømforsyning, der er CE markerede eller sikkerhed, som er blevet attesteret af en, som nationalt er blevet anerkendt prøve laboratorium.
- Sikkerhedslåget må være på plads før forbinding strømforsyningsblyet til en strømforsyning.
- Drejer alle strømforsyningskontroller af og afbryder kraftblyet før fjerning sikkerhedslåget.
- Cirkulerer bare vand eller 50/50 vand/ethylene glykol gennem varmeveksleren i så fald udrustet. Forbind ikke varmeveksleren til en vandhane eller nogen kølemiddelkilde hvor vandtrykket er unreguleret.
- Introducerer Aldrig antifreeze eller noget organisk opløsningsmiddel ind i nogen del af instrumentet. Organiske opløsningsmidler vil forårsage uboelig skade til enheden!
- Driver ikke med stødpudetemperaturer over maksimummet specificerede tekniske specifications. Overhedning vil forårsage uboelig skade til enheden!

Waste Electrical and Electronic Equipment (WEEE)

English



This symbol indicates that the waste of electrical and electronic equipment must not be disposed as unsorted municipal waste and must be collected separately. Please contact an authorized representative of the manufacturer for information concerning the decommissioning of your equipment.

French



Ce symbole indique que les déchets relatifs à l'équipement électrique et électronique ne doivent pas être jetés comme les ordures ménagères non-triées et doivent être collectés séparément. Contactez un représentant agréé du fabricant pour obtenir des informations sur la mise au rebut de votre équipement.

German



Dieses Symbol kennzeichnet elektrische und elektronische Geräte, die nicht mit dem gewöhnlichen, unsortierten Hausmüll entsorgt werden dürfen, sondern separat behandelt werden müssen. Bitte nehmen Sie Kontakt mit einem autorisierten Beauftragten des Herstellers auf, um Informationen hinsichtlich der Entsorgung Ihres Gerätes zu erhalten.

Italian



Questo simbolo indica che i rifiuti derivanti da apparecchiature elettriche ed elettroniche non devono essere smaltiti come rifiuti municipali indifferenziati e devono invece essere raccolti separatamente. Per informazioni relative alle modalità di smantellamento delle apparecchiature fuori uso, contattare un rappresentante autorizzato del fabbricante.

Spanish



Este símbolo indica que el equipo eléctrico y electrónico no debe tirarse con los desechos domésticos y debe tratarse por separado. Contacte con el representante local del fabricante para obtener más información sobre la forma de desechar el equipo.

Swedish



Denna symbol anger att elektriska och elektroniska utrustningar inte får avyttras som sorterat hushållsavfall och måste samlas in separat. Var god kontakta en auktoriserad tillverkarrepresentant för information angående avyttring av utrustningen.

Gel Electrophoresis Unit Function and Description

The Hoefer® SE600 series vertical slab gel electrophoresis units are intended for protein and nucleic acid electrophoresis under commonly used denaturing and non-denaturing conditions. Up to 28 samples can be compared on a single slab gel.

Applications include protein separations, nucleic acid fractionation, and the second-dimension separation of 2-D electrophoresis. First-dimension separation of 2-D protein electrophoresis should be performed on Immobilized pH Gradient Gels. The focused strips are easily transferred to the second-dimension slab gel for size separation.

All gel plates are 18 cm wide. Table 1 on page 8 lists both models and the corresponding gel plate length (16 or 24 cm). Up to four gels can be run at one time if sandwiches are paired into “club sandwiches.” The heat exchanger allows buffer temperature control in the lower chamber.

Specifications

Gel plate size (w × h)	SE600: 18 × 16 cm SE660: 18 × 24 cm
------------------------	--

Gel size SE600:	14 or 16 × 16 cm 16 cm with 1 cm wide spacers 14 cm with 2 cm wide spacers
-----------------	--

Gel size SE660:	14 or 16 × 24 cm 16 cm with 1 cm wide spacers 14 cm with 2 cm wide spacers
-----------------	--

Maximum watt	50 W
--------------	------

Maximum volt	1000 V
--------------	--------

Maximum ampere	500 mA
----------------	--------

Maximum temperature	45 °C
---------------------	-------

Environmental operating conditions	Indoor use: 4–40 °C Humidity up to 80% Altitude up to 2000 m Installation category: II Pollution degree: 2
------------------------------------	--

Dimensions (w × h × d)	SE600 32 × 29 × 14 cm (12.5 × 11.5 × 5.5 in.) SE660 32 × 37 × 14 cm (12.5 × 14.5 × 5.5 in.)
------------------------	--

Product certifications	EN61010-1, UL61010A-1, CSA C22.2 1010.1, CE Certified
------------------------	--

This declaration of conformity is valid only when the instrument is:

- used in laboratory locations,
- used as delivered from Hoefer, Inc. except for alterations described in the user manual, and
- connected to other CE-labeled instruments or products recommended or approved by Hoefer, Inc.

Fig 1. Main components of the SE600 series (see Fig 5 for caster components).

Included but not shown:

- Gel Seal compound, 1/4 oz.
- Spacer-Mate spacer positioning guide
- Glass plates (6)
- Wonder Wedge plate separation tool
- Buffer dam

Complete unit also includes spacers (4) and combs (2).

Required but not included:

- Magnetic stirrer
- Power supply with a minimum rating of 300 V, 100 mA (constant A or V)

Optional: Circulator bath

Note: The ordering section lists all accessories and replacement parts.

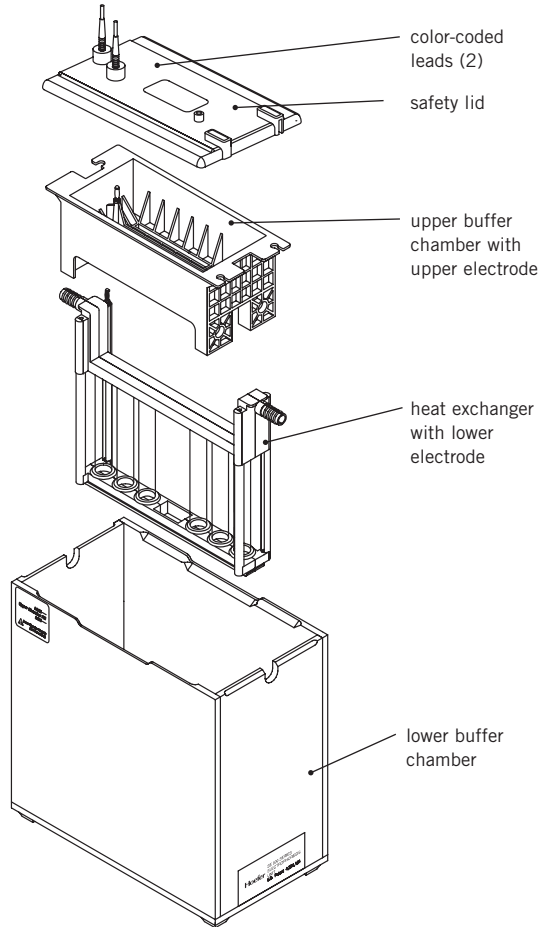

Note: Before using the first time, disassemble the unit and wash with a dilute solution of a laboratory detergent and rinse thoroughly first with water and then with distilled water.

Unpacking and Inventory

Unwrap all packages carefully and compare contents with the packing list, making sure all items arrived. If any part is missing, contact your local sales office. Inspect all components for damage that may have occurred while the unit was in transit. If any part appears damaged, contact the carrier immediately. Be sure to keep all packing material for damage claims or to use should it become necessary to return the unit.

Lower buffer chamber

The lower buffer chamber is transparent acrylic, which allows visual tracking of electrophoresis progress. The chamber is chemically resistant to common electrophoretic buffers but not to organic solvents or strong acids and alkali. Temperatures above 45 °C may cause the chamber to warp.

Upper buffer chamber

The upper buffer chamber is molded polysulfone, which is chemically resistant to common electrophoretic buffers but not to organic solvents or strong acids and alkali. The upper electrode (cathode) runs along the center ridge, and terminates at the banana plug. The upper chamber requires 0.5–0.8 liters of buffer (fill no higher than the top of the plastic ribs).

Heat exchanger

The heat exchanger must be installed for every use because it houses the bottom electrode (anode), which runs along the bottom of the frame. When connected to a circulator bath, the heat exchanger regulates the buffer temperature in the lower chamber. Coolant passes through the glass tubes, which are secured with silicone rubber grommets. The heat exchanger connector ports are 13 mm o.d. The heat exchanger is

rated to a maximum of 0.8 atmospheres above ambient (12 psig). Connect only to coolant sources with regulated pressure. (Do not connect to the water tap.)

Safety lid

The banana plug on the heat exchanger connects to the red lead and the plug on the upper buffer chamber connects to the black lead. The 4-mm shrouded color-coded leads plug into color-coded jacks in the power supply. Always install the safety lid before use!

Glass plates

All plates are 18 cm wide, but each model accommodates a specific plate length: The SE600 takes 16-cm plates, and the SE660 takes 24-cm plates. Three sets of glass plates are included with each unit. Notched divider plates, ordered separately, pair two gel sandwiches to form a “club sandwich” so that up to four gels can be run at one time.

Clamps

Two 16-cm clamps are used to secure any length sandwich. An additional pair of 8-cm clamps are required to secure 24-cm sandwiches. The clamp pressure bar, adjusted with screws, distributes pressure evenly.

Casting stand

The casting stand holds assembled gel sandwiches upright for casting gels. Adjustable feet level the caster. A laminated gasket in the bottom of each casting cradle seals the bottom of the sandwich when it is cammed into the stand.

Cams

Cams are used twice: first, to secure the assembled sandwich in the casting stand and, second, to attach the sandwich to the upper buffer chamber.

Rubber gaskets

There are two sets of two gaskets: The solid laminated gaskets fit into the bottom of the casting stand and form the seal for casting the gel. The slotted gaskets fit under the upper buffer chamber and form the seal between the upper and lower chambers. The ridges on the upper gasket align the gasket slot to maintain an open channel between the top of the gel and the buffer in the upper chamber.

Spacers

(May be ordered separately.) Spacers determine the thickness of the gel and are available in three thicknesses (0.75, 1.0, and 1.5 mm) and two widths (1.0 and 2.0 cm).

Spacer-Mate spacer positioning guide

Aligns spacers for sandwich assembly.

Combs

(May be ordered separately.) Combs are available in sizes that form 10, 12, 15, 20, or 28 wells. Preparative combs include 1 or 2 reference wells in addition to a preparative well. Most combs are available in all three thicknesses: 0.75, 1.0, and 1.5 mm.

All preparative combs and 10, 12, 15 and 20-well combs form wells that are 25 mm deep. The 28-well comb forms wells that are only 15 mm deep so that wells do not collapse when the comb is removed. The sample volume held by each well depends on the gel thickness, well depth and the number of wells per comb. Table 2 lists sample volumes of each well for all combs.

Wonder Wedge plate separator tool

Used to disassemble gel sandwiches and to gauge spacer and comb thickness.

Operating Instructions

Gel casting and electrophoresis procedures follow. Assembly of both models is identical. Included are instructions for polyacrylamide gels (used with continuous or discontinuous buffer systems), and gradient gels. See page 30 for the Bibliography.

Prepare the gel sandwich

Glass plates, spacers, and clamp sets are sized so that the assembled sandwich can be easily aligned to create the seal required first to cast the gel and then to run it. For best results, **take extra care to align all components when assembling sandwiches**. Table 1 summarizes gel casting options.

SE600

Both precast gels and self-cast gels can be used. To self-cast multiple gels, kits can be ordered separately: the SE615 Multiple Gel Caster Kit holds up to 10 sandwiches, and the SE675 Gel Caster Kit holds up to four sandwiches. (See the accompanying gel caster user manual for complete instructions.)

SE660

The 24-cm gels required for the SE660 must be self-cast. The Dual Gel Caster (included) holds two gel sandwiches.

Table 1: Gel casting options

model	no. of gels	gel plate size (cm)	available gels and casters
SE600	1-4*	18 x 16	Dual Gel Caster Gel Caster Kit [§] Multiple Gel Caster Kit [†] Commercially available gels
SE660	1-4*	18 x 24	Dual Gel Caster

*Two accessory notched divider plates are required to run 2 extra gels.

[§]Casts up to 4 gels

[†]Casts up to 10 gels

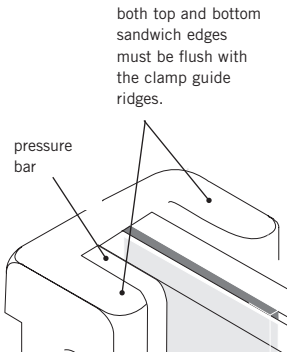

Fig 2. Sandwich assembly:

Inspect glass plates for nicks. Use only unchipped plates to prevent leaking.

Tip: Use the casting cradle to hold the sandwich during alignment. Remove the laminated gasket from the cradle and, instead of setting the sandwich upright on a flat surface, set it into the casting cradle.

Construct the gel sandwich and insert into caster

1

Prepare the caster and clamps

Place the spirit level into the caster center and adjust the leveling feet. Loosen all clamp screws and make space for the sandwich by sliding the pressure plates toward the screws.

2

Construct gel sandwiches

For each sandwich choose two perfectly clean, unchipped glass plates and two spacers. Lay one plate on a flat surface, lay the Spacer-Mate alignment template onto the plate (wide side at the top of the plate), place a spacer along each edge, and lay the second glass plate on top.

Fig 3. Required number of clamps.

	Clamp size	
	8 cm	16 cm
SE600	—	2
SE660	2	2

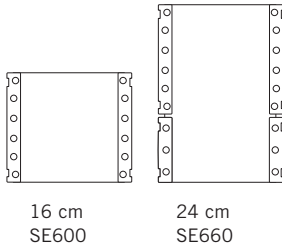
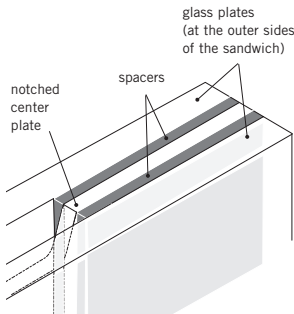

Fig 4. Club sandwich assembly. Side clamps will accommodate two spacers up to 1.5 mm thick.



Note: Do not use silicone grease or petroleum jelly to seal the sandwich. These substances are difficult to remove and ultimately cause artifacts.

3

Secure the sandwich with clamps

Slide one clamp at a time along the sandwich sides. Finger tighten one screw on each clamp, set the sandwich upright on a flat surface, and loosen the screw to align the stack. Take great care in aligning to ensure a seal. Finger tighten all screws. Remove the Spacer-Mate.

Long sandwiches require two clamp assemblies on each side. When assembling 24-cm sandwiches, align each end separately. That is, align one end, finger-tighten the screws, turn the sandwich 180° and align the other end. In each case allow the clamp to slide down and align perfectly with the top (or bottom) edge of the glass plates.

Club sandwich

A 16- or 24-cm long, notched center divider plate (ordered separately) pairs two sandwiches to double the number of gels that can be cast and run.

Assemble a club sandwich in the same manner as a regular sandwich, except before placing the top glass plate, lay the divider plate and a second set of spacers on the stack. Place the notch so that it will be at the top of the gels. It is essential that the spacers and plates align perfectly in order to create a seal. For 24-cm long plates, position the 8-cm clamp along the side at the bottom of the sandwich farthest from the notch.

4

Remove the sandwich and inspect the bottom to make sure that edges are aligned flush in order to ensure a complete seal. Adjust if necessary.

Optional: Apply a light film of Gel Seal compound only on the bottom corner surfaces created by the spacers and plates if your sandwiches continue to leak after several attempts of alignment.

5

Place the laminated gasket into the casting cradle (See Fig 5) with the *foam side down*. Place the clamp assembly in the casting cradle, screw side facing out. For 24-cm plates, place the sandwich so that the longer clamp is at the top.

6

Insert a cam into the hole on each side of the casting tray with the ridge (short end) pointing up. Seal the gel sandwich against the casting gasket by turning both cams as far as needed, usually 90° to 150° , up to 180° . The cam action presses the plates down into the gasket and to seal the bottom of the sandwich. The seal is complete once the glass edge appears darker and nearly transparent against the gasket. Do not turn the cam past this point.

Note: When turning the cams, it is easier to keep the caster balanced if you turn both toward the center of the caster.

Fig 5. Caster components and setup.

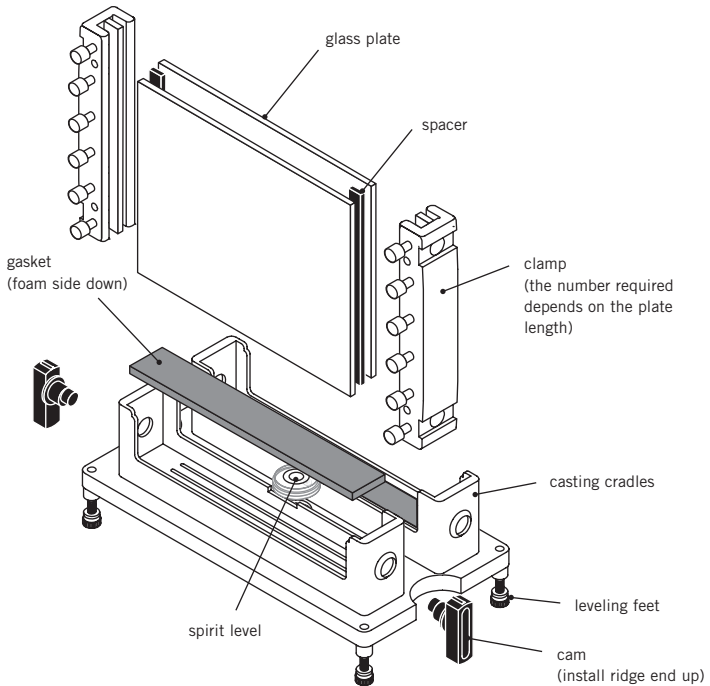

Acrylamide Gels

1

Prepare the monomer solution and pour the gel

Prepare the required amount of monomer solution. Deaerate and add the initiator and catalyst just prior to pouring the gel. Pipette the solution into one corner of the sandwich, taking care not to introduce any air bubbles. See below for the appropriate solution level according to the application.

No stacking gel (Continuous system)

Fill solution to just below the top of the upper plate edge. If bubbles are trapped, remove with a pipette or syringe. Introduce a comb (at a slight angle) into each sandwich, taking care not to trap air bubbles under the teeth.

Club sandwich

Pipette the solution into both sandwiches, filling each to the same level below the notched edge.

Stacking gel

Fill solution to 3–4 cm below the top of the glass plate. This height allows 1 cm of stacking gel below the wells. Pour the gel and apply an overlay (see step 2). After the gel is set, prepare the stacking gel as described below.

2-D electrophoresis (Discontinuous protein system)

Fill monomer solution to about 1 cm below the top of the glass plate to allow 4–5 mm for the IPG strip or tube gel and an agarose seal. (A stacking gel will require extra space). Seal the IPG strip or tube gel in place with agarose dissolved in running buffer. Take care to avoid trapping any air bubbles between the first- and second-dimension gels.

2

Overlay each gel with a thin layer of water-saturated butanol, water, or diluted gel buffer to prevent gel exposure to oxygen. *Slowly* deliver the overlay solution from a glass syringe fitted with a 22-gauge needle. Apply the solution near the spacer at one side of the sandwich and allow it to flow across the surface unaided.

3

Allow the gel to polymerize for a minimum of 1 hour.

Stacking gel preparation

Pour the stacking gel while the sandwich is still in the gel caster. Stacking-gel resolution is optimal when poured just before electrophoresis.

1

Remove the overlay by rinsing the top of the gel several times with distilled water. Invert the caster to drain. To ensure a seamless contact between the resolving and stacking gels, remove residual liquid by blotting one corner with a lab wipe.

2

Calculate the stacking gel monomer solution volume.

3

Prepare the stacking-gel monomer solution, deaerate it, and add catalyst and initiator. Pour the stacking gel onto the resolving gel with a disposable or Pasteur pipette to a level about 2 mm from the top of the plate.

4

Introduce a comb (at a slight angle) into the sandwich, taking care not to trap air under the teeth. Allow a minimum of 1 hour for the gel to polymerize.

Gradient Gels

Both linear and exponential gradient gels can be poured in the dual-gel caster. We recommend using a Hoefer SG Series Gradient Maker.

Gradient gels are poured from the top of the caster with a cannula if using the provided dual-gel caster or from the bottom if using a Hoefer Multiple Gel Caster (see instructions accompanying the caster). A stacking gel is then poured over the gradient gel.

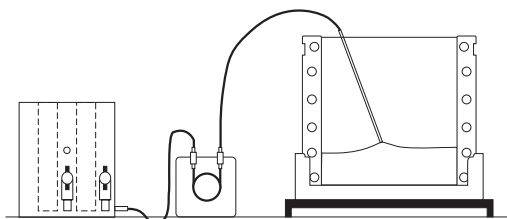

Fig 6. Pouring a gradient gel.

A pipette tip may be used instead of a cannula if the gel solution is delivered at a rate that maintains a continuous stream on the glass surface.

Note: Gradient gels poured in the SE615 or SE675 Multiple Gel Caster are introduced through the bottom.

Note: When pouring an exponential gradient gel, position a plunger or sealing plug above the liquid in the mixing chamber to hold the volume constant.

Pouring a linear gradient gel

1

Assemble sandwich(es) into the dual-gel casters as described on page 8.

2

Set up the monomer solution flow path

Run a length of clear vinyl tubing through a peristaltic pump. Attach one end of the tubing to the gradient maker outlet port and the other end to a 20 cm cannula. (The o.d. of the cannula must be less than the spacer thickness.) Place the cannula so that it rests at the bottom of the sandwich, midway between the spacers.

Optional: Adjust the higher-percentage acrylamide solution to 15% (w/v) sucrose or 25% (v/v) glycerol to improve layering.

3

Prepare the monomer solution

Calculate the volume of monomer solution needed. Divide the total volume in half and prepare this volume of both the higher- and lower-percentage acrylamide solutions.

4

Pour the “light” solution into the reservoir chamber (the chamber farthest from the outlet). Open the stopcock between the chambers long enough to displace the air and then close. Pour the “heavy” solution into the mixing chamber and place a stirring bar into this chamber. Place the gradient maker onto a magnetic stirrer and begin stirring at a rate that mixes well but does not introduce bubbles into the solution.

5

Mix the gradient and pump the solution into the sandwich

While the solution is stirring, begin pumping from the mixing chamber and open the stopcock to the reservoir chamber. Raise the cannula as liquid enters the sandwich, keeping the tip at the gel surface. Prepare more gels as required.

6

Overlay each gel with a thin layer of water-saturated n-butanol, water, or diluted gel buffer to prevent gel exposure to oxygen. Slowly deliver the overlay solution from a glass syringe fitted with a 22-gauge needle. Apply the solution near the spacer at the side of the sandwich and allow it to flow across the surface unaided.

7

Allow the gels to polymerize for a minimum of 1 h. After polymerization, pour off the overlay and rinse the gel surface several times with distilled water.

8

Prepare the stacking-gel monomer solution, pour the stacking gel, and introduce a comb (at a slight angle) into the sandwich, taking care not to trap air under the teeth. Allow a minimum of 1 h for the gel to polymerize.

Note: With Coomassie Blue™ it is possible to detect 1 µg of protein in a single band. With the more sensitive silver stains, it is possible to detect as little as 10 ng of protein.

Sample Preparation and Loading

The sample can be loaded either while the sandwich is in the caster or after the upper buffer chamber is attached. When loading samples while using divider plates, the samples must be loaded without the upper buffer chamber in place.

The amount of sample loaded depends on the thickness of the gel, the sensitivity of the detection method used, and the amount of sample expected in each band. In a continuous buffer system, the protein sample should be relatively concentrated, because no stacking gel is used. In a discontinuous buffer system, the zone into which each molecular species migrates is sharpened by the stacking gel, so the sample need not be as concentrated.

1

Prepare the wells

Remove the comb by gently rocking it side to side and then lifting it straight up to avoid damaging the well walls. Carefully rinse each well with distilled water to remove unpolymerized acrylamide and then drain by inverting the gel sandwich (or caster). Fill each well with electrophoresis buffer.

2

Prepare the sample

Increase liquid sample density with 10% glycerol or sucrose. Add a tracking dye such as phenol red, bromophenol blue, or pyronin Y.

For SDS protein gels, use 2X treatment buffer to denature both liquid and dry samples in a test tube.

To **liquid protein solutions**, add an equal volume of 2X buffer.

To **dry protein samples**, add equal volumes of 2X sample buffer and high-purity water to achieve the desired concentration.

Note: Once the samples are in the wells, take care to not jar the sandwiches so that the samples are not spilled or mixed.

3

Heat the tube in boiling water for 90 seconds, then allow to cool to room temperature. Treated samples can be stored at -40 to -80 °C for future runs.

Heat membrane proteins to 60 °C for 20 minutes. Store unused sample at 4 °C.

4

Underlay the sample into the wells using a fine-tipped microsyringe or gel-loading pipette tip.

**Table 2. Sample volume for standard comb sizes
volume of sample (µl) per 1 mm depth**

no. of wells	comb thickness (mm)		
	0.75	1.0	1.5
10	6.2	8.3	12.4
12	5.8	7.7	11.5
15	4.3	5.7	8.6
20	3.1	4.1	6.2
28	2.1	2.7	4.1
1/1 (ref/prep)	4/90	6/121	9/183
1/2 (ref/prep)	4/85	6/112	9/171

Final Assembly

Fig 7. Attaching gel sandwiches to the upper buffer chamber.

If the assembly leaks, take it to a sink and partially release the cams to allow buffer to drain out of the upper chamber. Disassemble, check alignment of all sandwich components, and adjust if necessary.

A. Remove cams from the lower cam holes. Place the upper chamber onto the sandwiches and then insert the cams into the upper cam holes, ridge (short end) pointing down.

B. The final cam position (not shown) must be vertical so that the assembly fits into the lower buffer chamber.

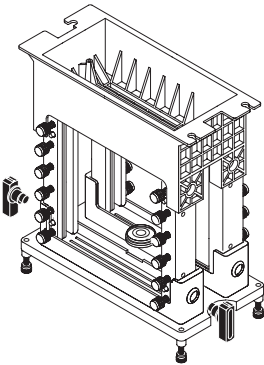

Note: Do not force the cams. If you encounter unusual resistance, disassemble and inspect clamp and glass alignment along the top of the sandwich. Align and reinstall.

Upper buffer chamber

1

Rinse both buffer chambers with water and distilled water thoroughly before each use.

Clean away any gel adhering to the exterior of the gel sandwiches.

2

If running only one gel: Block the second upper buffer chamber slot by installing the acrylic buffer dam included with the unit. Fit clamps onto the dam, taking care to align the clamp ends and dam edges. Install the “dummy” gel, screws facing out, in the second cradle in the dual gel caster.

3

Attach the gel sandwich to the upper buffer chamber

Turn the upper buffer chamber upside down and place a slotted gasket into both sandwich holder recesses. Both the slot in the gasket and the slot in the recess must align. Both slotted gaskets must be used even if running only one gel sandwich. Grooves along each slot help keep the gasket in place. Additionally, a small amount of Gel Seal can be applied at each end of the gasket before install to help hold the gasket against the upper buffer chamber.

Release the sandwiches from the caster by removing all bottom cams (if present). Lower the upper buffer chamber onto the gel sandwiches in the casting stand. Install the cams, ridge pointing down, into the buffer chamber cam holes. Clamp the sandwich in place by simultaneously turning one cam clockwise and the other counterclockwise a *full* 180°.

4

Use a pipette to carefully fill each slot above the sample wells with buffer to minimize disturbing the samples. Then pour 100 ml of buffer into the chamber, directing the buffer stream toward the side wall. Check that no buffer leaks around the gasket.

Lower buffer chamber

1

Place a magnetic spin bar into the lower buffer chamber (LBC) and place the unit on a magnetic stirrer. Fill the lower chamber with up to 4 liters of buffer.

2

Lower the heat exchanger into the lower chamber, fitting the ports into the notches in the rim. (The heat exchanger must be in place for all runs because the lower electrode is integrated into the heat exchanger.) If no cooling is required, skip to step 3.

Optional: Connect the heat exchanger to a thermostatic circulator. Slide hose clamps (four total) onto each end of two lengths of 10–12 mm i.d. (3/8–1/2") vinyl or silicone tubing. Attach one end of each length of tubing to a heat exchanger port. Attach the free ends of each length of tubing to the circulator bath ports, one to the inlet and the other to the outlet. Secure the connections with the hose clamps.

Use the chart (Fig 8, on page 19) to estimate a starting point for the circulator bath temperature setting. Adjust as necessary for variables such as ambient temperature, changes in power output, and circulator bath efficiency. If accurate temperature control is critical, measure the temperature and adjust as necessary.

Optional: Prechill the buffer.

Note: If the cooling option is used frequently, it is convenient to attach QuickFit connectors to the tubing. The valves in these fittings prevent coolant spillage.

Fig 8. Approximate circulator bath temperature setting. Set the circulator bath temperature setting lower than the desired run temperature by the amount indicated on the graph. This should be checked at three points.

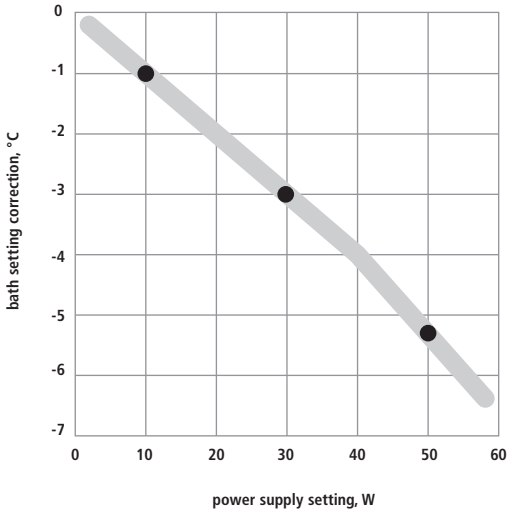

Example:

Run parameters: 200 V, 0.05 A (50 mA)

1. Calculate W if your power supply does not display power directly:

$$W = V \times A$$
$$10 W = 200 V \times 0.05 A$$

2. Interpolate the number of degrees to subtract from the desired run temperature.

10 W intersects the graph at about -1 °C.
If the desired temperature is 23 °C, set the bath to 23 - 1 = 22 °C.
If the desired temperature is 4 °C, set the bath to 4 - 1 = 3 °C.

Fig 9. Buffer chamber levels.

Approximate volumes required:
SE600 4.5 liters
SE660 7.0 liters

- Low voltage runs
- Systems using the same buffer in both the upper and lower chambers

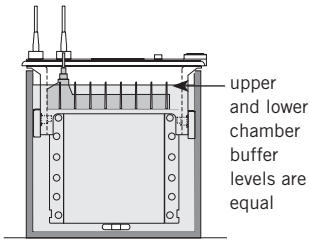

–or–

Approximate volumes required:
SE600 4.0 liters
SE660 6.0 liters

- High voltage runs
- Isoelectric focusing
- Systems using different buffers in the upper and lower chambers

The buffer level should cover most of the gel sandwich (to allow the dissipation of heat) but must allow at least 2 cm clearance below the upper buffer chamber.

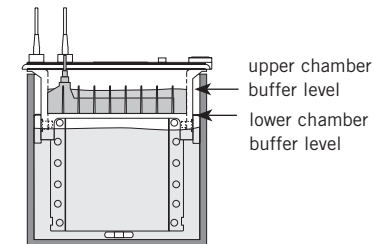

3

Fit the upper buffer chamber assembly into the lower buffer chamber. Use a steady hand to avoid disturbing the samples: Grasp the assembly in the casting stand by the upper buffer chamber and carefully lower it into the lower chamber.

4

Inspect the installation and check the buffer levels.

Upper buffer chamber (UBC). The electrode along the upper chamber ridge must be submerged about 1 cm. This level requires 450–600 ml of buffer, just enough to cover the upper chamber ribs, but not high enough to contact the banana plug.

Lower buffer chamber (LBC). The lower buffer level depends on running conditions and the buffer system as described in Fig 9.

5

Place the safety lid on the unit.

6

Plug the color-coded leads into the jacks of an approved power supply. Plug the red lead into the red output jack and the black lead into the black output jack. In most systems, the red lead, which is connected to the bottom electrode, is the anode (+), and the black lead, connected to the top electrode, is the cathode (–).

Important assembly notes:

- IEF Runs: The buffer level in the lower buffer chamber must never reach the upper buffer chamber; maintain at least 2 cm of clearance.
- Do not fill the upper or lower chamber above the recommended levels illustrated in Fig 9. Remove buffer in contact with the electrode posts.
- Pour buffer slowly and away from the slots in the upper buffer chamber to avoid disturbing the samples.
- Use only water or 50/50 water/ethylene glycol as coolant. Never use a commercial antifreeze or any alcohol-based mixture, or irreparable damage to the heat exchanger will result.
- Do not connect the heat exchanger to a water tap or any other source where the water pressure is unregulated.

Separating the Sample

Note: All SE600 series units uses 18-cm-wide plates. The gel thickness determines the cross section (and current requirement) for constant current runs. The length of the plate determines the running time.

Table 3: Laemmli buffer system starting point guidelines

Gel thickness*	1.5 mm
Current per gel [†]	25 mA constant current
Starting voltage [‡]	80–90 V
Final voltage	220–250 V

*Thicker or thinner gels require proportionally more or less current. For example, a 0.75 mm gel, which is half as thick as a 1.5 mm gel, requires half as much current, or 12.5 mA.

[†]The current must be multiplied by the number of gels. For instance, if two club sandwiches are installed, the four gels require four times as much current. The current can be increased for faster runs if active cooling is used and it can be decreased for slower overnight runs.

[‡]At 25 mA per gel.

Electrophoresis parameters for discontinuous polyacrylamide gels

Gels may be run at either constant current or constant voltage settings. A constant current mode is traditionally used with a discontinuous buffer system so that the rate of electrophoretic migration remains unchanged throughout the run. Under these conditions voltage increases as the run proceeds. A lower current setting is recommended for higher resolution. The optimal current level must be determined empirically; the main factors that must be balanced include the gel concentration and migration speed, and the resulting Joule heating and band distortion. Table 3 lists starting-point guidelines and adjustments for gel thickness, number of gels, and migration rate.

Current

Current acts on the total cross-section area of all the gels because the gels are connected in parallel in the electrical circuit. Thus the current setting for one gel must be multiplied by the number of gels of the same cross-section run simultaneously. For a gel 1.5 mm thick, we suggest a starting current setting of 25 mA. (Two 1.5 mm gels = 50 mA.)

Note: Cooling may be required to control Joule heating.

Voltage

The starting voltage for a 1.5 mm slab gel connected to a power supply set to 25 mA is usually 80 to 90 V (using the SE600 with a Laemmli discontinuous buffer system for SDS gels). The final voltage is typically 250 to 400 V, depending on the length of the gel. (See Table 3.)

Time

A run is complete when the tracking dye reaches the bottom of the gel. In a 16-cm gel (SE600), a 1.5-mm thick Laemmli SDS gel, run at 25 mA/gel without cooling, usually requires 5 hours. Longer gels require proportionally more time; separations in 24-cm gels (SE660) require 8 hours.

Electrophoresis parameters for DNA/acrylamide gels

DNA gels are usually run at a constant voltage setting, and since buffer systems are continuous, both current and voltage readings remain constant throughout the run. Running conditions are expressed in units of V/cm. Published running conditions vary widely, but voltages in the range of 1 to 3 V/cm are common for overnight runs. In the SE600, we have run gels at up to 12.5 V/cm. (Cooling is required at this voltage level.)

Record each run

Keep a record of the current or voltage setting, number and thickness of gels, buffer system, and the starting and final current or voltage readings for each run so that results can be compared. Inconsistent results for the same system and settings indicate potential problems such as leaking current, incorrect buffer concentrations, high salt concentrations or inconsistent chemical quality.

Check band progress after 5 minutes, and again after an hour, keeping an eye on the migration rate of the tracking dye. The run is complete when the tracking dye reaches the bottom of the gel. Watch the buffer level and, if necessary, replenish it as required to keep the top electrode submerged. (A small volume of buffer may leak past a nicked plate or gasket, or buffer may pass through the gel.)

Caution! After initial monitoring, do not leave the unit unattended for more than 1 h before checking the progress of the bands and the buffer level.

After electrophoresis

①

Once the tracking dye reaches the bottom of the gel, turn off the power supply, disconnect the leads, and remove the safety lid, using finger leverage between the lid and the top of the heat exchanger. (Lift straight up to avoid bending the banana plugs.)

②

If coolant is circulating, stop the flow and disconnect the fittings or tubing.

③

Pull out the upper buffer chamber assembly. Pour the buffer into a sink. Install the assembly in the dual gel caster and then release the sandwiches by turning and removing the cams.

④

Unscrew the clamps from the sandwiches and remove. Gently loosen and then slide away both spacers. Use the Hoefer Wonder Wedge Gel Plate Separation tool to separate the plates.

⑤

Carefully lift the glass plate with the gel attached. *Handle the gel with care to avoid damaging it.* Invert the plate and position the gel low over the staining tray. Pry one corner of the gel away from the glass and allow it to drop into the tray, or, if the gel is thick enough to handle, lift it and place it into the tray. To avoid splashing, add staining or fixative solution to the tray after the gel is transferred.

⑥

Clean the unit as described in the next section.

Note: Use only flexible plastic prying tools to avoid chipping the glass plates.

Care and Maintenance

Cleaning

- Do not autoclave or heat any part above 45 °C.
- Do not use organic solvents, abrasives, strong cleaning solutions, or strong acids or bases to clean the chambers.
- Do not soak the laminated gasket.

Immediately after each use, rinse the upper and lower buffer chambers with water and then rinse thoroughly with distilled water. Handle the upper buffer chamber with care to prevent damaging the banana plug. Clean gaskets with mild detergent and rinse with distilled water. Allow to air-dry.

Clean glass plates and spacers with a dilute solution of a laboratory cleanser such as RBS-35[®], then rinse thoroughly with tap and distilled water. Glass plates can also be treated with (but not stored in) acid cleaning solutions.

Replacing a heat exchanger glass tube

1

Remove the tube by simultaneously twisting and sliding it down as far as possible, until the top end is free of the upper grommet. Carefully guide the tube so that it will clear the assembly, then lift the tube out of the lower grommet.

2

Lightly grease the outside of both ends of the new tube with silicone grease. Twist and slide one end of the tube into the lower grommet. Then slip the other end into the top grommet, gently pushing it with a slight twist until it stops.

3

Check that the grommet is not pinched.

Note: If the old tube is cracked or broken, protect your hand with thick gloves, a piece of cloth, or paper towel before removing the tube.

Troubleshooting

problem	possible cause	remedy
Gel sandwich leaks while casting	Dirty or damaged components	Plates, spacers, and the gasket must be completely clean. Wash if necessary. Replace chipped plates (especially if chipped near the spacers). Check the caster gasket for cuts or cracks and replace if necessary.
	Mis-aligned parts	Check plate and spacer alignment, realign if necessary.
	Over-clamping	Turn cam only as far as necessary to create a seal (usually 90–150°, but up to 180°). On each spacer apply a light film of Gel Seal compound to the bottom outside corner only. Do not use silicone grease.
Sample wells damaged or irregular	Air bubbles	Remove air bubbles before inserting combs. Slide comb into solution at an angle. If comb must be removed, add more monomer solution before reinserting the comb.
	Incomplete or delayed polymerization	Allow acrylamide gels to set for a minimum of 1 h.
	Debris in wells	Rinse out unpolymerized gel with sample buffer.
	Comb removal	Remove the comb at a slight angle and very slowly to prevent damaging the gel. Agarose gels: Lower the comb no more than 1 cm into the gel.
Incomplete gel polymerization	Chemicals	Use only recent stocks of the highest-quality reagents. If the dry ammonium persulfate does not crackle when added to water, replace with fresh stock. Increase TEMED or APS concentration, or both.
	pH	Solutions with extreme pH values (especially acidic) may not polymerize.
	Oxygen	Remove oxygen from the gel environment: Degas the monomer solution 5–10 min before pouring and then overlay the gel surface with water-saturated n-butanol.
	Temperature	Adjust the gel solution temperature to a minimum of 20 °C, especially for low %T gels.

problem	possible cause	remedy
Upper buffer chamber leaks	Mis-aligned parts	Check that the glass plates, spacers, and clamps are aligned and fit snugly into the upper chamber gasket. Check that both gaskets are centered and that the positioning ridges fit inside the grooves.
	Dirty or damaged components	Check that the gasket is not damaged or pinched. Replace if necessary. Check that the upper buffer chamber is not warped from prior exposure to excessive heat.
Power supply detects current leak	Electrical path to outside ground/earth	Add more silicone grease to seal heat exchanger grommets. Check for leaks or cracks in the heat exchanger. Replace worn grommets.
Dye front curves up (smiles) at edges	Uneven heat distribution	Fill the lower buffer chamber to the level appropriate for at edges the run. (See Fig 9, page 20). Use magnetic stirrer and stir bar to keep buffer well mixed.
	Excessive heat	Circulate ext. coolant. Decrease the current or voltage setting. Prechill the buffer. Run the gel in the cold room.
Protein streaks vertically	Particulates in sample	Centrifuge or filter sample before loading to remove particulates.
	Overloading	Load less sample.
	Degradation	Add protease inhibitor such as PMSF.
Unusually slow (or fast) run	Current leakage around gel	Check for leaks; all plates and spacers must be aligned and free of grease and cracks. If used, the buffer dam must be secure.
	Sample or reagent preparation	If the required pH of a solution is overshot, do not back-titrate. Discard and prepare fresh buffer. Check recipes, gel concentrations, and buffer dilution. (For instance, do not use Tris-HCl instead of Tris for Laemmli tank buffer.) Decrease the salt concentration of samples.
	Reagent quality	Dispose of older acrylamide solutions and use only stock of the highest quality. Use only freshly deionized urea.
	Voltage or current settings	To increase or decrease the migration rate, adjust the voltage or current by 25–50%.

problem	possible cause	remedy
Bands are skewed or distorted	Incomplete gel preparation and polymerization	Degas the stacking-gel solution and avoid trapping air bubbles under the comb teeth.
	Irregular interface between stacking and running gels	Overlay the running gel with water-saturated butanol before polymerization begins, to avoid forming an uneven gel surface.
	Sample preparation	Dialyze or desalt the sample.
Stained sample collects:		
<i>Near the buffer front</i>	Gel concentration	Molecules are not sufficiently restricted by the resolving gel pore size: increase the %T.
	Degradation	Proteins may be degraded by endogenous proteases: use protease inhibitors during the isolation step.
<i>Near the top of the gel when the buffer front has reached the bottom</i>	Gel concentration	The gel pore size is too small: decrease the %T of the resolving (or stacking) gel.
	Precipitation	The protein has precipitated. Heat the sample at a lower temperature (70 °C or less) for 1–2 min.
<i>At both top and bottom of the gel</i>	Gel concentration	The molecular weight range of the sample requires an acrylamide concentration gradient to resolve the full range of protein sizes.
Tracking dye doesn't sharpen into a concentrated zone in the stacking gel	Poor stacking	Pour a taller stacking gel. (For best results, allow a stacking-gel height of 2.5 times the height of the sample in the well.)
	Reagent quality	Dispose of outdated acrylamide solutions and use only the highest grade of acrylamide.
	Sample preparation	When preparing samples, avoid using solutions with high salt concentrations.

problem	possible cause	remedy
Poor band resolution	Running conditions	<p>Begin electrophoresis as soon as the sample is loaded to prevent low molecular weight species from diffusing.</p> <p>Conduct the separation at a lower current or voltage setting to reduce Joule heating.</p>
	Reagent quality	Use only the highest-quality reagents.
	Poor stacking	<p>Use only gels that were recently prepared.</p> <p>Add a stacking gel or increase height of the stacking gel. Prepare the resolving-gel surface by first rinsing it with stacking-gel monomer before pouring the stacking gel to ensure continuity between the gels.</p> <p>Check pH values of the resolving- and stacking-gel solutions. Do not back-titrate buffers.</p>
	Incomplete gel polymerization	Allow gel to polymerize fully.
	Sample preparation	<p>Store sample on ice before it is denatured.</p> <p>Dialyze or desalt the sample.</p> <p>Heat samples in SDS sample buffer for no more than 1–2 min at 100 °C to improve dissociation of subunits. Store on ice after heating.</p> <p>Adjust the sample volume or concentration.</p> <p>Add more mercaptoethanol or dithiothreitol; check sample treatment.</p> <p>Add protease inhibitors such as PMSF if necessary to prevent proteolytic degradation of sample.</p> <p>Increase glycerol or sucrose to increase sample density.</p> <p>Store samples to be frozen in aliquots to avoid repeated freeze-thawing. Store at -40 to -80 °C.</p>

Bibliography

General

- Gallagher, S. R., and Smith, J. A., Electrophoretic separation of proteins. In *Current Protocols in Molecular Biology*. (Ausubel, F. A., eds.), OSC 10.2.1–10.2.21 (1991).
- Hames, B. D., and Rickwood, D., *Gel Electrophoresis of Proteins: A Practical Approach*: Second edition, City IRL Press (1990).
- Sambrook, J., and Russell, D.W., *Molecular Cloning: A Laboratory Manual*. Cold Spring Harbor Laboratory, Cold Spring Harbor, NY (2001).
- Sasse, J., and Gallagher, S. R., Staining proteins in gels. *Current Protocols in Molecular Biology*. (Ausubel, F. A., *et al.*, eds.), OSC 10.6.1–10.6.8 (1991).
- SDS Polyacrylamide Gel Electrophoresis and Isoelectric Focusing Handbook* (80-6013-88), Hoefer, Inc. (2001).

Non-denaturing gel systems

- Reisfeld, R. A., *et al.*, Acidic buffer system for resolution of cationic proteins. *Nature*. **195**, 281 (1962).
- McLellan, T. Electrophoresis buffers for polyacrylamide gels at various pH values. *Anal. Biochem.* **126**, 94 (1982).
- Hedrick, J. L. and Smith, A. J., Size and charge isomer separation and estimation of molecular weights of proteins by discontinuous gel electrophoresis. *Arch. Biochem. Biophys.* **126**, 155 (1968).

Denaturing gel systems

- Laemmli, U. K. Cleavage of structural proteins during the assembly of the head of bacteriophage T. *Nature*. **227**, 680–685 (1970).
- Matsudaira, P. T. and Burgess, D. R., SDS microslab linear gradient polyacrylamide gel electrophoresis. *Anal. Biochem.* **87**, 386–396 (1978).
- Schreier, M. H., Erni, B., and Staehelin, T., Initiation of mammalian protein synthesis. I. Purification and characterization of seven initiation factors. *J. Mol. Biol.* Nov; **116**(4):727–753 (1977).

Shapiro, A. L., and Maizel J. V. Jr., Molecular weight estimation of polypeptides by SDS-polyacrylamide gel electrophoresis: further data concerning resolving power and general considerations. *Anal. Biochem.* Jun; **29**(3):505–514 (1969).

Schaegger, H. and Von Jagow, G., Tricine-sodium dodecyl sulfate-polyacrylamide gel electrophoresis for the separation of proteins in the range from 1 to 100 kDa. *Anal. Biochem.* **166**, 368–379 (1987).

Weber, K., and Osborn, M., The reliability of molecular weight determinators by dodecyl sulfate-polyacrylamide gel electrophoresis. *J. Biol. Chem.* **224**, 4406–4412 (1969).

Two-dimensional electrophoresis

Adams, L. D. and Gallagher, S. R., Two-Dimensional Gel Electrophoresis Using the O'Farrell System. *Current Protocols in Molecular Biology*, (Ausubel, F. A., et al, eds.), OSC pp. 10.4.1–10.4.13 (1992).

Anderson, N. G., Anderson, N. L., and Tollaksen, S. L., Proteins of human urine. I. Concentration and analysis by two-dimensional electrophoresis. *Clin. Chem.* Jul; **25**(7): 1199–2210 (1979).

Anderson, Leigh and Anderson, Norman G., High resolution two-dimensional electrophoresis of human plasma proteins. *Proc. Natl. Acad. Sci. USA.* **74**:5421–5425 (1977).

Anderson, L. *Two-Dimensional Electrophoresis, Operation of the ISO-DALT® System*, Second Edition. Large Scale Biology Press (1991).

Bravo, R., Schafer, R., Willecke, K., MacDonald-Bravo, H., Fey S. J., and Celis J. E., More than one-third of the discernible mouse polypeptides are not expressed in a Chinese hamster-mouse embryo fibroblast hybrid that retains all mouse chromosomes. *Proc. Natl. Acad. Sci. USA.* Apr; **79**(7):2281–2285 (1982).

Hurkman, W. J., and Tanaka, C. K., Solubilization of Plant Membrane Proteins for Analysis by Two-Dimensional Gel Electrophoresis. *Plant Physiology.* **81**:802–806 (1986).

Mets, L. J. and Bogorad, L. Two-dimensional polyacrylamide gel electrophoresis: an improved method for ribosomal proteins. *Anal Biochem.* Jan; **57**(1):200–210 (1974).

-
- O'Farrell, P. H., High resolution two-dimensional electrophoresis of proteins. *J. Biol. Chem.* May 25; 250(10):4007–4021 (1975).
- Bjellqvist, B., *et al.*, Isoelectric focusing in immobilized pH gradients: principle, methodology and some applications. *J. Biochem. Biophys. Methods* 6, 317–339 (1982).
- Görg, A., *et al.*, The current state of two-dimensional electrophoresis with immobilized pH gradients. *Electrophoresis* 9, 531–546 (1988).
- Görg, A. Two-dimensional electrophoresis with immobilized pH gradients: current state. *Biochem. Soc. Trans.* 21, 130–132 (1993).
- Bjellqvist, B., *et al.*, Micropreparative two-dimensional electrophoresis allowing the separation of samples containing milligram amounts of proteins. *Electrophoresis* 14, 1375–1378 (1993).
- Blomberg, A., *et al.*, Interlaboratory reproducibility of yeast protein patterns analyzed by immobilized pH gradient two-dimensional gel electrophoresis. *Electrophoresis* 16, 1935–1945 (1995).

Ordering Information

product	quantity	code number
for 18 × 16 cm gels		
SE600 Dual Cooled Vertical Unit, basic. Includes: 3 sets of glass plates, four 16 cm clamp assemblies, 6 cams, dual gel casting stand with leveling base and level, buffer dam, Spacer-Mate alignment template and Wonder Wedge plate separation tool. (Order 2 combs and 2 sets of 16 cm spacers separately.)	1	SE600
SE600 Dual Cooled Vertical Unit, complete. Includes: basic unit plus two 15-well combs and 2 spacers 1.5-mm thick.	1	SE600-15-1.5
for 18 × 24 cm gels		
SE660 Dual Cooled Vertical Unit, basic. Includes: 3 sets of glass plates, four 16-cm and four 8-cm clamp assemblies, 6 cams, dual gel casting stand with leveling base and level, buffer dam, Spacer-Mate alignment template and Wonder Wedge plate separation tool. (Order 2 combs and 2 sets of 24 cm spacers separately.)	1	SE660
SE660 Dual Cooled Vertical Unit, complete. Includes: basic unit plus two 15-well combs and 2 spacers 1.5-mm thick.	1	SE660-15-1.5
Replacement parts		
Wonder Wedge gel plate separation tool	1	SE1514
Slotted silicone rubber gaskets for upper buffer chamber	2	SE6008B
Laminated silicone rubber gaskets for casting stand	2	SE6009
Buffer dam	1	SE6032
Upper buffer chamber for SE600, SE660	1	SE6054
Lid with high voltage leads for SE600, SE660	1	SE6056
High-voltage safety lead set	1	SE6056-HV
Lower buffer chamber for SE600	1	SE6150
Heat exchanger for SE600 and SE660	1	SE6160

product	quantity	code number
Lower buffer chamber for SE660	1	SE6650
Grommets for heat exchanger/lower electrode assembly	4	SE6060-6
Banana plug, gold, with 2 washers	1	SE6067
Glass tube with 2 grommets for heat exchanger/lower electrode assembly	1	SE6160-5
Spirit level	1	SER11
Gel Seal, 1/4 oz. tube	1	SE6070

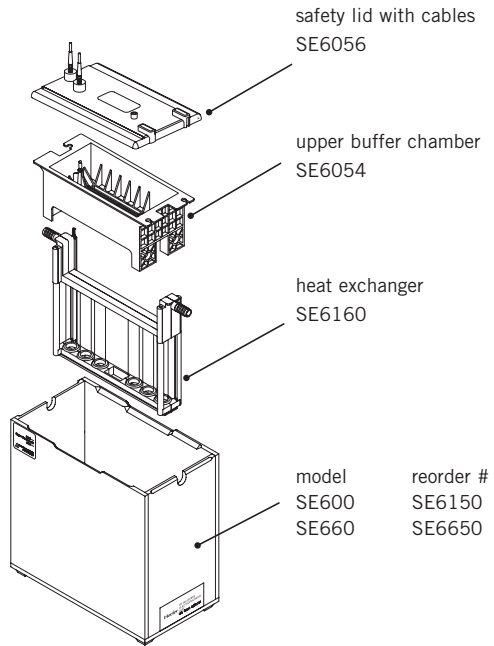

product	quantity	code number
---------	----------	-------------

Gel casters

For 1 or 2 gels:

Dual Gel Caster, basic, 2 gels, 18 cm wide	1	SE6015
---	---	--------

Includes: 2 blank gaskets for 1 or 2 gels.
(One included with each SE600 unit.)

For up to 4 gels:

Gel Caster Kit, 4 gels, 18 × 16 cm or 18 × 8 cm	1	SE675
--	---	-------

Includes: 8 glass plates, 3 space-saver plates, 5 filler sheets, 100 sheets of wax paper, Spacer-Mate alignment template, and filler plugs. (Order combs and spacers separately.)

For up to 10 gels:

Multiple Gel Caster Kit, 10 gels, 18 × 16 cm	1	SE615
---	---	-------

Includes: 20 glass plates, space-saver plate, 5 filler sheets, 100 sheets of wax paper, Spacer-Mate alignment template and filler plugs. (Order combs and spacers separately.)

product	quantity	code number
---------	----------	-------------

Clamps and cams

Clamp and Cam Kit, four 16 cm clamps and 8 black cams	1	SE6003UK
Replacement thumbscrews for clamps	12	SE6003U-2
Cams, black, for clamps with cam holes	4	SE6005L
Clamp assemblies, 16 cm	2	SE6003U
Clamp assemblies, 8 cm	2	SE6403U

Glass plates

18 × 16 cm

Glass plates	2	SE6102
Glass plates, low fluorescence	2	SE6102LF
Glass plate, club sandwich divider, notched	1	SE6102D

18 × 24 cm

Glass plates	2	SE6602
Glass plate, club sandwich divider, notched	1	SE6602D

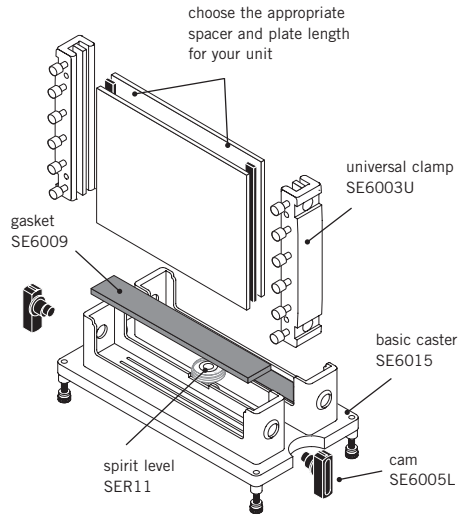

Combs

number of wells	thickness (mm)	width (mm)	quantity	code number
10	0.75	8.3	1	SE511-10-.75
10	1.00	8.3	1	SE511-10-1.0
10	1.50	8.3	1	SE511-10-1.5
12	0.75	7.6	1	SE511-12-.75
12	1.00	7.6	1	SE511-12-1.0
12	1.50	7.6	1	SE511-12-1.5
15	0.75	5.7	1	SE511-15-.75
15	1.00	5.7	1	SE511-15-1.0
15	1.50	5.7	1	SE511-15-1.5
20	0.75	4.1	1	SE511-20-.75
20	1.00	4.1	1	SE511-20-1.0
20	1.50	4.1	1	SE511-20-1.5
28 ^a	0.75	2.7	1	SE511-28-.75
28 ^a	1.00	2.7	1	SE511-28-1.0
28 ^a	1.50	2.7	1	SE511-28-1.5

^aComb depth 15 mm; all others 25 mm.

Preparative combs

These combs are 25 mm deep, adjustable to 10 or 15 mm.

no. of wells prep/ref	thickness (mm)	width (mm) prep/ref	quantity	code number
1/1	0.75	121/6	1	SE511-R-.75
1/1	1.00	121/6	1	SE511-R-1.0
1/1	1.50	121/6	1	SE511-R-1.5
1/2	0.75	113/6	1	SE511-DR-.75
1/2	1.00	113/6	1	SE511-DR-1.0
1/2	1.50	113/6	1	SE511-DR-1.5

Adjustable comb back 1 SE511-BKA

Required to convert any 25-mm deep comb to 10 or 15 mm depth.

Spacers

thickness (mm)	length (cm)	width (cm)	quantity	code number
1.00	16	1	2	SE6118-2-1.0
1.50	16	1	2	SE6118-2-1.5
0.75	16	2	2	SE6119-2-.75
1.00	16	2	2	SE6119-2-1.0
1.50	16	2	2	SE6119-2-1.5
0.75	24	2	2	SE6619-2-.75
1.00	24	2	2	SE6619-2-1.0
1.50	24	2	2	SE6619-2-1.5

Companion products

Hoefer SE100 Plate Mate washing and storage unit	1	SE100
QuickFit connectors, female 3/8"	2	QF3/8
QuickFit connectors, male 3/8"	2	QFX3/8



Hoefer, Inc.

32 Scotland Blvd, Ste. 9,
Bridgewater, MA02324, USA

Toll Free: 1-800-813-0488

Phone: 1-508-807-4665

E-mail: support@hoeferinc.com

Web: www.hoeferinc.com

Hoefer is a registered trademark
of Hoefer, Inc.

© 2023 Hoefer, Inc.

— All rights reserved.

