

Oil-Sealed Rotary Vacuum Pump

GLD-137CC/201B



GLD Series, Direct Drive Oil-Sealed

■ Features

- GLD series features high performance, low vibration and noise and several functions such as gas ballast valve, oil-back-flow prevention mechanism, and large sized oil level gauge. This series equips multi-voltage motor and correspondent to international standard

■ Applications

- Chemical, science experiment, analyzer and laser system
- Backing pumps for electronic microscope
- Semiconductor equipment, sputtering equipment, vacuum evaporation equipment
- Vacuum dryer, freeze dryer
- Db noise level 57 db(A) or less

■ Specifications

Model	Unit	GLD-137CC for ADP Series		GLD-201B for DP Series	
		50Hz	60Hz	50Hz	60Hz
Actual pumping speed	L/min	135	162	200	240
	m ³ /h	8.1	9.72	12.00	14.40
	CFM	4.77	5.72	7.06	8.47
	Pa	G.V. Closed : 0.67 G.V. Open : 6.7		G.V. Closed : 0.67 G.V. Open : 6.7	
Ultimate pressure	Torr	G.V. Closed : 5.0×10^{-3} G.V. Open : 0.05		G.V. Closed : 5.0×10^{-3} G.V. Open : 0.05	
	mbar	G.V. Closed : 6.7×10^{-3} G.V. Open : 0.07		G.V. Closed : 6.7×10^{-3} G.V. Open : 0.07	
	Motor	Single phase, 400W, 4P, Multiple-range motor Capacitor start & run, 100–120V/200–240V		Single phase, 550W, 4P, Multiple-range motor Capacitor start & run, 100–120V/200–240V	
Full load current	A	6.8 (100-120V) 3.5 (200-240V)	5.8 (100-120V) 2.9 (200-240V)	8.2 (100-120V) 4.1 (200-240V)	7.9 (100-120V) 3.9 (200-240V)
Oil capacity	mL	1000		1100	
Recommended oil		SMR-100		SMR-100	
Weight	kg	27.0		29.0	
Inlet port diameter	mm	KF-25		KF-25	
Ambient temperature	°C	7-40		7-40	
	°F	44.6 – 104		44.6 – 104	
Overall dimensions	mm	170(W) × 488(L) × 250(H)		170(W) × 516(L) × 250(H)	

■ Corresponding Voltage and Certificate

Model	Voltage	Applicable Volt	CE Marked	TUV Marked	cTUVus Marked
GLD-137CC	Single phase, 100-120V	Standard	●	●	●
	Single phase, 200-240V	Standard	●	●	●
GLD-201B	Single phase, 100-120V	Standard	●	●	●
	Single phase, 200-240V	Standard	●	●	●

Pumping Speed Curves

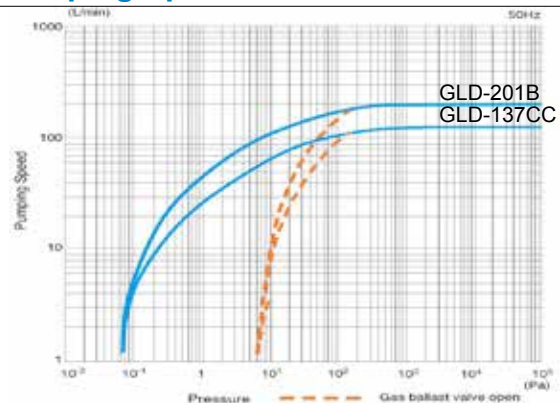

GLD-137CC for ADP Series

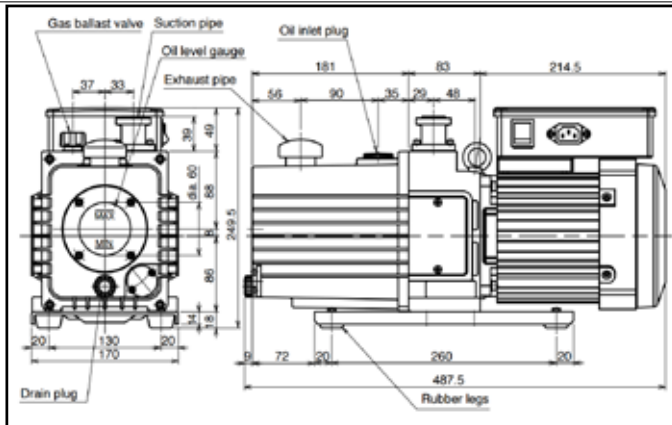

ADP Series Oven (Hose Connection)

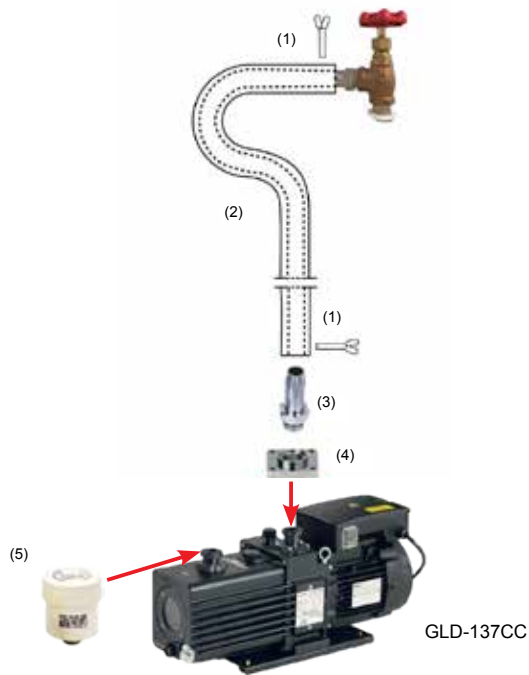

	Description
(1)	Hose Clamp
(2)	Rubber Hose ID: 16mm/1500mm
(3)	Hose Port Type Suction Pipe OD: 18mm x M20
(4)	50mm Square Adapter for Suction Port
(5)	Oil Mist Trap

GLD-201B for DP Series

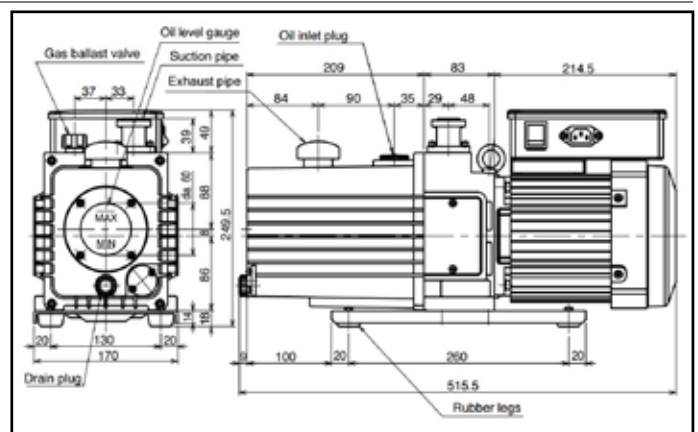

DP Series Oven (NW25 Flange Connection)

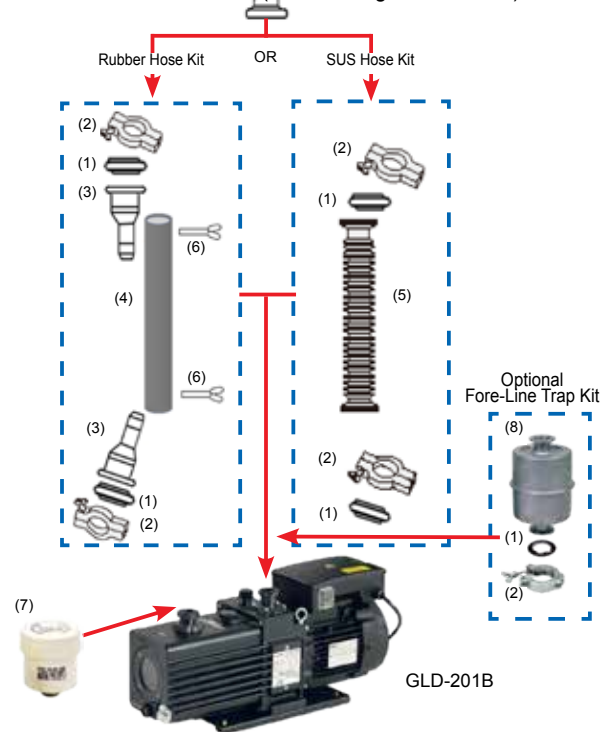

	Description
(1)	NW25 Centering O-Ring
(2)	NW25 Hinged Clamp
(3)	NW25 Hose Nozzle 21mm
(4)	Rubber Hose ID 21mm / 1500mm
(5)	SUS Flexible Hose KF25 x 1500mm
(6)	Hose Clamp
(7)	Oil Mist Trap
(8)	Fore-Line Trap

Description	Product Code	Applicable products	Components
Rotary Vacuum Pump			
GLD137CC with Rubber Hose Kit 115V	GLD137CC115DPRKIT	ADP200C/210C/300C/310C	Vacuum pump, Oil mist trap, Hose clamp, Rubber hose, Suction pipe, Square adapter
GLD137CC with Rubber Hose Kit 220V	GLD137CC220DPRKIT	Vacuum Oven Series	Vacuum pump, Oil mist trap, Hose clamp, Rubber hose, Suction pipe, Square adapter
GLD202BB with Rubber Hose Kit 115V* <i>previously GLD201B115DPRKIT</i>	GLD202BB115DPRKIT <i>new model number</i>	DP43C/63C Vacuum Oven Series	Vacuum pump, Oil mist trap, Centering o-ring, Hinged clamp, Hose nozzle, Rubber hose, Hose clamp
GLD201B with SUS Hose Kit 115V*	GLD201B115DPSKIT		Vacuum pump, Oil mist trap, Centering o-ring, Hinged clamp, Hose nozzle, SUS flexible hose, Hose clamp
GLD201B with Rubber Hose Kit 220V*	GLD201B220DPRKIT		Vacuum pump, Oil mist trap, Centering o-ring, Hinged clamp, Hose nozzle, Rubber hose, Hose clamp
GLD201B with SUS Hose Kit 220V*	GLD201B220DPSKIT		Vacuum pump, Oil mist trap, Centering o-ring, Hinged clamp, Hose nozzle, SUS flexible hose, Hose clamp

* Optional Fore-Line Trap Kit not included in the kit above.