



# T-Station 300

## INSTRUCTION MANUAL

# Copyright notice

©Edwards Limited 2023. All rights reserved.

Published: 11/2/2023

## Associated publications

Title	Reference	Link
Diaphragm pump - XDD1 Mk3	A74603885	<a href="https://4vac.io/immy3y">https://4vac.io/immy3y</a>
Rotary vane pumps - E2M0.7 / E2M1.5	A37132880	<a href="https://4vac.io/64zcqu">https://4vac.io/64zcqu</a>
nEXT Turbomolecular Pumps nEXT240, nEXT300 and nEXT400	B80000880	<a href="https://4vac.io/hc7umv">https://4vac.io/hc7umv</a>
Miniscroll pump mXDS3s	A74401880	<a href="https://4vac.io/64y98z">https://4vac.io/64y98z</a>

## Trademark credit

Edwards and the Edwards logo are trademarks of Edwards Limited, Innovation Drive, Burgess Hill, West Sussex, UK, RH15 9TW

## Disclaimer

The content of this manual may change from time to time without notice. We accept no liability for any errors that may appear in this manual nor do we make any expressed or implied warranties regarding the content. As far as practical we have ensured that the products have been designed and constructed to be safe and without risks when properly installed and used in accordance with their operating instructions.

We accept no liability for loss of profit, loss of market or any other indirect or consequential loss whatsoever.

Product warranty and limit of liability are dealt with in our standard terms and conditions of sale or negotiated contract under which this document is supplied.

You must use this product as described in this manual. Read the manual before you install, operate, or maintain the product.

# Contents

<b>1. Safety and compliance.</b> . . . . .	<b>6</b>
1.1 Definition of Warnings and Cautions. . . . .	6
1.2 Trained personnel . . . . .	6
1.3 Safety symbols. . . . .	7
<b>2. General description.</b> . . . . .	<b>8</b>
2.1 Overview. . . . .	8
<b>3. Technical data.</b> . . . . .	<b>10</b>
3.1 Operating and storage conditions. . . . .	10
3.2 Mechanical data. . . . .	10
3.3 Pump performance data. . . . .	13
3.4 Pumped media. . . . .	14
3.5 Venting gas specification and vent control data. . . . .	15
3.6 Materials exposed to gases pumped. . . . .	16
3.7 Electrical connections. . . . .	16
3.8 Electrical data. . . . .	18
<b>4. Installation.</b> . . . . .	<b>20</b>
4.1 Installation safety. . . . .	20
4.2 Unpack and inspect. . . . .	20
4.3 Locate the pumping system. . . . .	21
4.4 Bench top fixing. . . . .	21
4.4.1 Bench top fixing with straps. . . . .	21
4.4.2 Bench top fixing with screws. . . . .	22
4.5 Fill the pump with oil. . . . .	22
4.6 Connect to the vacuum system. . . . .	22
4.7 Connect to the exhaust extraction system. . . . .	23
4.8 Connect the electrical supply. . . . .	23
4.9 Configure the pumping system. . . . .	24
4.9.1 Turbo pump delay. . . . .	24
4.9.2 Connect a vacuum gauge. . . . .	25
<b>5. Commission the system.</b> . . . . .	<b>26</b>
5.1 Installation checklist. . . . .	26
5.2 Test the system. . . . .	26
<b>6. Operation.</b> . . . . .	<b>28</b>
6.1 Control panel description. . . . .	28
6.2 Menu structure. . . . .	29

6.2.1 Turbo screen. . . . .	30
6.2.2 Gauge screen. . . . .	31
6.2.3 Vent valve screen. . . . .	32
6.2.4 Turbo setpoint screen. . . . .	33
6.2.5 Calibrate gauge screen. . . . .	35
6.2.6 Units screen. . . . .	36
6.3 Gas ballast control. . . . .	37
6.4 Electrical supply failure. . . . .	37
<b>7. Maintenance. . . . .</b>	<b>38</b>
7.1 Maintenance safety. . . . .	38
7.2 Maintenance plan. . . . .	38
7.3 Inspect the hoses, pipelines and connections. . . . .	39
7.4 Factory default settings. . . . .	39
<b>8. Fault finding. . . . .</b>	<b>40</b>
8.1 Error numbers. . . . .	41
<b>9. Storage. . . . .</b>	<b>43</b>
<b>10. Disposal. . . . .</b>	<b>44</b>
<b>11. Service. . . . .</b>	<b>45</b>
11.1 Return the equipment or components for service . . . . .	45
<b>12. Spares. . . . .</b>	<b>47</b>
<b>13. Accessories. . . . .</b>	<b>48</b>
13.1 TAV vent valve and vent port adaptor (for nEXT300 turbo pump). . . . .	48
13.2 Outlet mist filter(for E2M1.5 rotary vacuum pump). . . . .	48

## List of Figures

Figure 1: General view of the Pumping system. . . . .	9
Figure 2: Dimensions (T-Station with XDD1 backing pump option). . . . .	11
Figure 3: Dimensions (T-Station with E2M1.5 backing pump option). . . . .	12
Figure 4: Dimensions (T-Station with mXDS3s backing pump option). . . . .	13
Figure 5: Max allowed rate of pressure rise during venting: pressure against time (pump initially at full speed). . . . .	16
Figure 6: Pin connections for 15-way sub-miniature 'D' type socket. . . . .	17
Figure 7: Pin connections for an 8-way RJ45. . . . .	18
Figure 8: Bench top fixing with straps. . . . .	22
Figure 9: Turbomolecular pump start delay with XDD1 diaphragm pump. . . . .	25
Figure 10: Menu structure. . . . .	30
Figure 11: Turbo screen. . . . .	31
Figure 12: Gauge screen. . . . .	32
Figure 13: Vent valve screen. . . . .	33
Figure 14: Turbo setpoint screen. . . . .	34
Figure 15: Turbo setpoint number entry mode. . . . .	35
Figure 16: Calibrate gauge screen. . . . .	36
Figure 17: Units screen. . . . .	36

# 1. Safety and compliance

For safe operation from the start, read these instructions carefully before you install or commission the equipment and keep them safe for future use. Read all the safety instructions in this section and the rest of this manual carefully and make sure that you obey these instructions.

The instruction manual is an important safety document that we often deliver digitally. It is your responsibility to keep the instruction manual available and visible while working with the equipment. Please download the digital version of the instruction manual for use on your device or print it if a device will not be available.

## 1.1 Definition of Warnings and Cautions

Important safety information is highlighted as warning and caution instructions which are defined as follows. Different symbols are used according to the type of hazard.

### **WARNING:**

**If you do not obey a warning, there is a risk of injury or death.**

### **CAUTION:**

**If you do not obey a caution, there is a risk of minor injury, damage to equipment, related equipment or process.**

### **NOTICE:**

**Information about properties or instructions for an action which, if ignored, will cause damage to the equipment.**

We reserve the right to change the design and the stated data. The illustrations are not binding.

## 1.2 Trained personnel







For the operation of this equipment “trained personnel” are:

- skilled workers with knowledge in the fields of mechanics, electrical engineering, pollution abatement and vacuum technology and
- personnel specially trained for the operation of vacuum pumps

## 1.3 Safety symbols

The safety symbols on the products show the areas where care and attention is necessary.

The safety symbols that we use on the product or in the product documentation have the following meanings:

	<p><b>Warning/Caution</b> Risk of injury and/or damage to equipment. An appropriate safety instruction must be followed or a potential hazard exists.</p>
	<p><b>Warning - Dangerous voltage</b> Risk of injury. Identifies possible sources of hazardous electrical shock.</p>
	<p><b>Warning - Heavy object</b> Risk of injury or damage to equipment. Identifies a possible hazard from a heavy object.</p>
	<p><b>Warning - Hot surfaces</b> Risk of injury. Identifies a surface capable of inflicting burns through contact.</p>
	<p><b>Warning - Moving parts present</b> Risk of injury. Identifies moving parts that may cause injury or damage to equipment.</p>
	<p><b>Warning - Risk of explosion</b> Risk of injury or damage to equipment. Identifies a situation that could result in an explosion.</p>
	<p><b>Warning - Use protective equipment</b> Risk of injury. Use appropriate Personal Protective Equipment (PPE) when performing the task.</p>

## 2. General description

For the general description of the major components used on the T-Station 300, refer to the appropriate instruction manual (refer to Associated publications on page 2).

<b>Product</b>	<b>Publication number</b>
Diaphragm pump - XDD1 Mk3	A74603885
Rotary vane pumps - E2M0.7 or E2M1.5	A37132880
Turbomolecular pumps - nEXT300	B80000880
Scroll pumps - mXDS3s	A74401880

### 2.1 Overview

The T-Station 300 is a small, compact and fully automatic pumping system which is suitable for a wide range of vacuum applications.

The system can be supplied with either an XDD1 oil-free diaphragm pump or an E2M1.5 rotary vane pump or mXDS3s scroll pump. All three system variants use a nEXT300 turbomolecular pump.

The system is controlled by an easy to use touch pad control module. A single gauge input included can be connected to a range of our active gauges allowing for pressure measurement and/or control management of the turbomolecular pump.

The compact size of the T-Station 300 is ideal for use on bench tops or suitable mobile platforms. The open system configuration allows easy maintenance of the main pump components.



**Figure 1** General view of the Pumping system

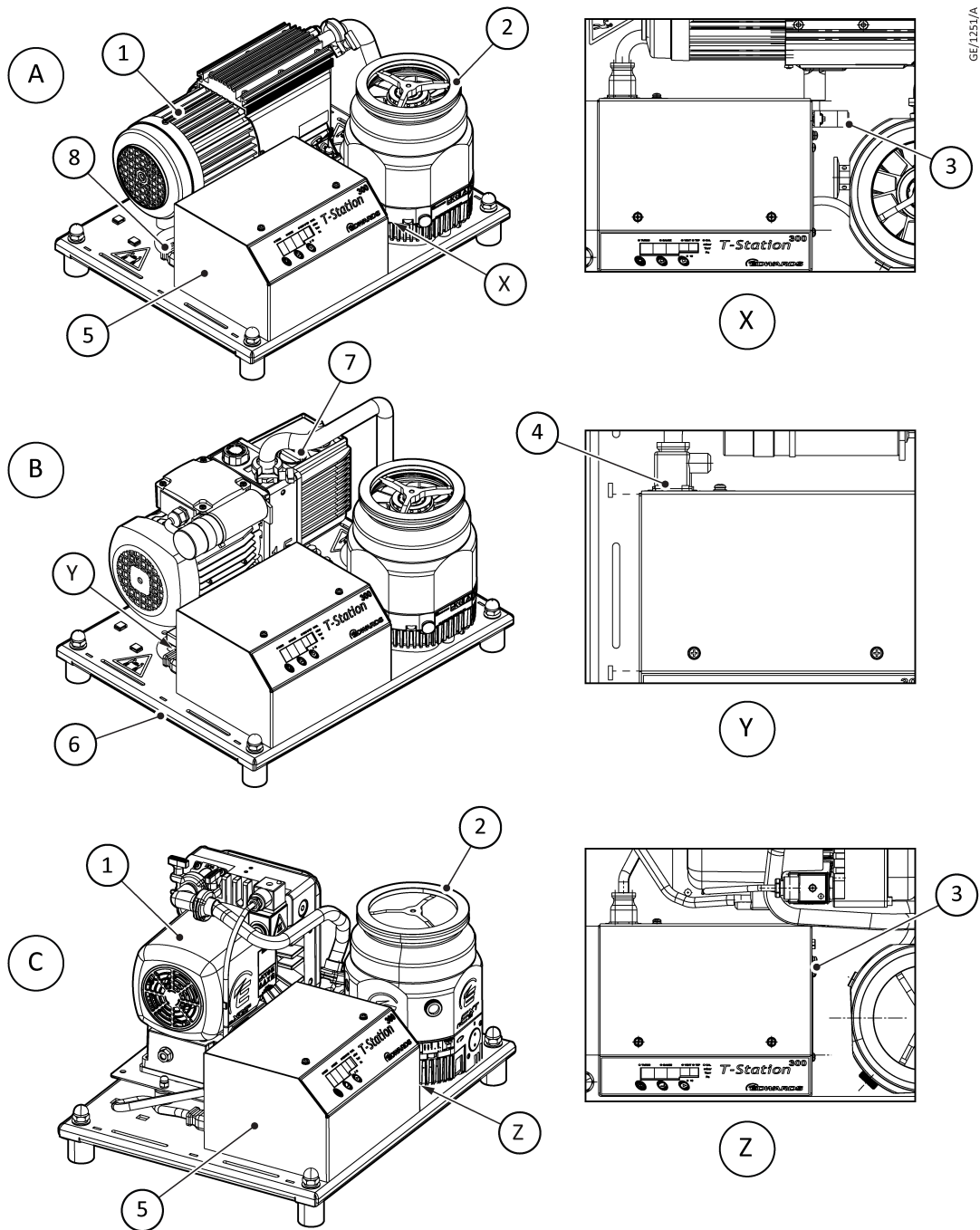

A. Front view (T-Station with E2M1.5 backing pump option)

B. Front view (T-Station with XDD1 backing pump option)

C. Front view (T-Station with mXDS3s backing pump option)

1. Backing pump

2. Turbomolecular pump inlet

3. Turbomolecular pump connector

4. Mains input

5. T-Station control unit

6. T-Station fixing points for bench top mounting

7. E2M1.5 gas ballast control

8. Backing pump mains connector

### 3. Technical data

 **Note:**

The operating, storage conditions and performance of the pumping system may depend on the type of backing pump used. Refer to the technical data in the appropriate supplementary publications as listed in [General description](#) on page 8.

#### 3.1 Operating and storage conditions

*Table 1 Operating and storage conditions*

Parameter	Value	Units
Ambient operating temperature range	12 to +35	°C
Ambient storage temperature range	-10 to +60	°C
Maximum operating humidity	maximum 90 condensing at 40	% RH and °C
Maximum operating altitude	2000 maximum	m
Sound level Declared dual number noise emission values in accordance with ISO4871	56 ± 3	dB(A)
Pollution degree (EN61010)	2	-
Maximum outlet pressure <ul style="list-style-type: none"> <li>▪ XDD1 pump</li> <li>▪ E2M1.5 pump</li> <li>▪ mXDS3s</li> </ul>	1.1 (1.1 x 10 <sup>5</sup> ) 1.5 (1.5 x 10 <sup>5</sup> ) 1.5 (1.5 x 10 <sup>5</sup> )	bar absolute (Pa)
Maximum system throughput (N <sub>2</sub> )	65	sccm
System leak tightness	<1x10 <sup>-6</sup>	mbar l s <sup>-1</sup>

#### 3.2 Mechanical data

*Table 2 Mechanical data*

Parameter	Data
Dimensions	Refer to <a href="#">Figure: Dimensions</a>
Degree of protection (to IEC34-5:1981)	IP20
Mass	
▪ XDD1 and nEXT ISO100 combination	21 kg
▪ XDD1 and nEXT CF100 combination	24 kg
▪ E2M1.5 and nEXT ISO100 combination	26 kg
▪ E2M1.5 and CF100 combination	29 kg
▪ mXDS3s and nEXT ISO100	23 kg
▪ mXDS3s and nEXT CF100	26 kg

Figure 2 Dimensions (T-Station with XDD1 backing pump option)

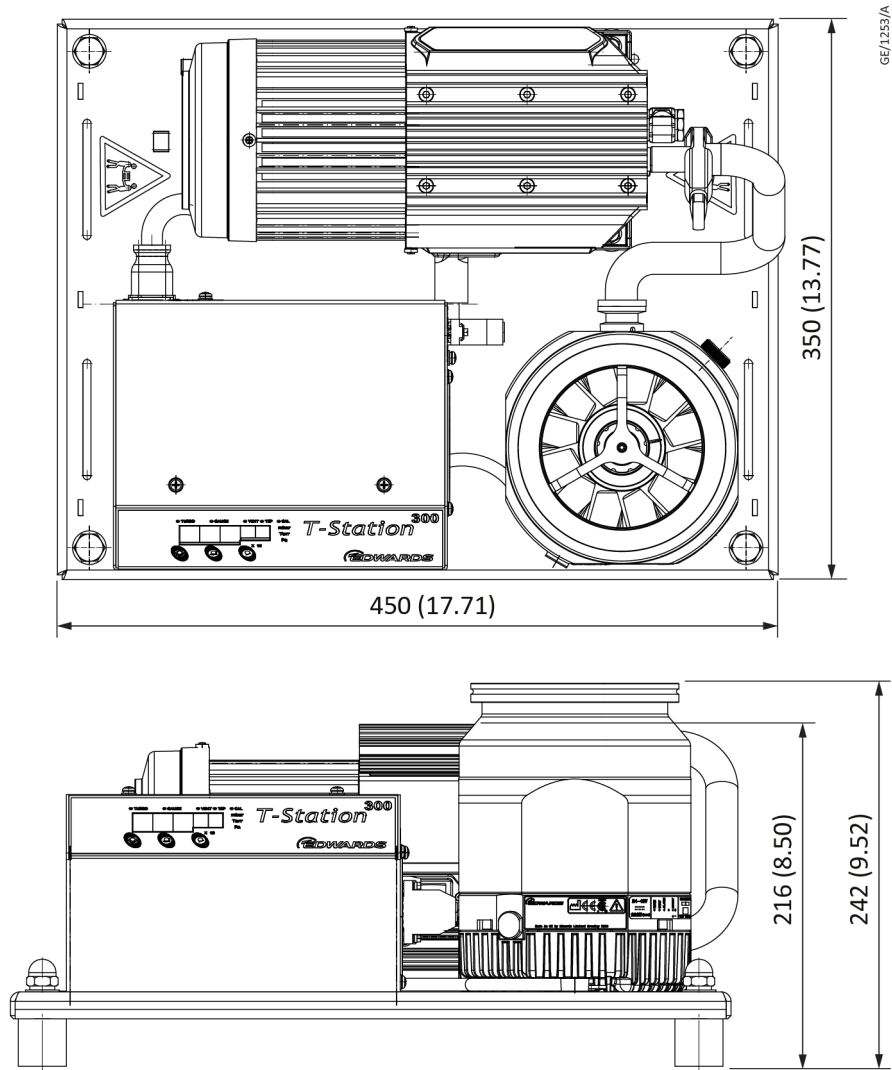

All measurements indicated are shown in mm (inches)

Figure 3 Dimensions (T-Station with E2M1.5 backing pump option)

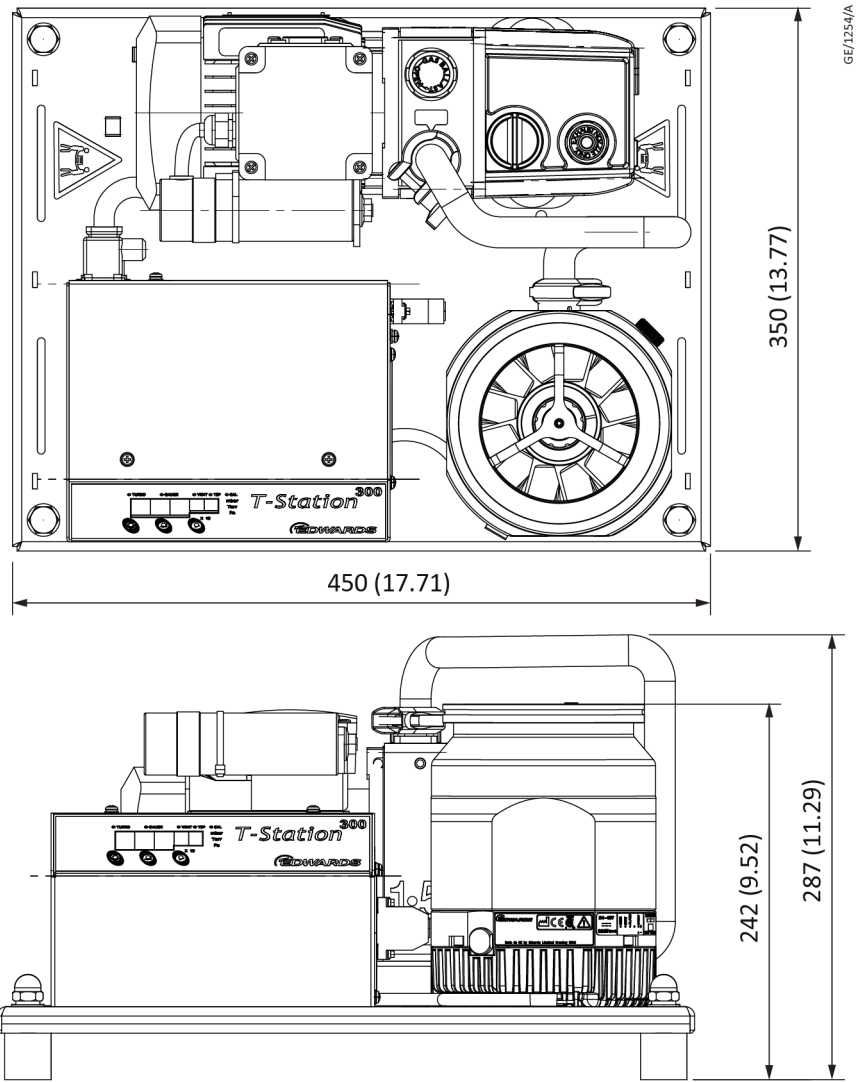

All measurements indicated are shown in mm (inches)

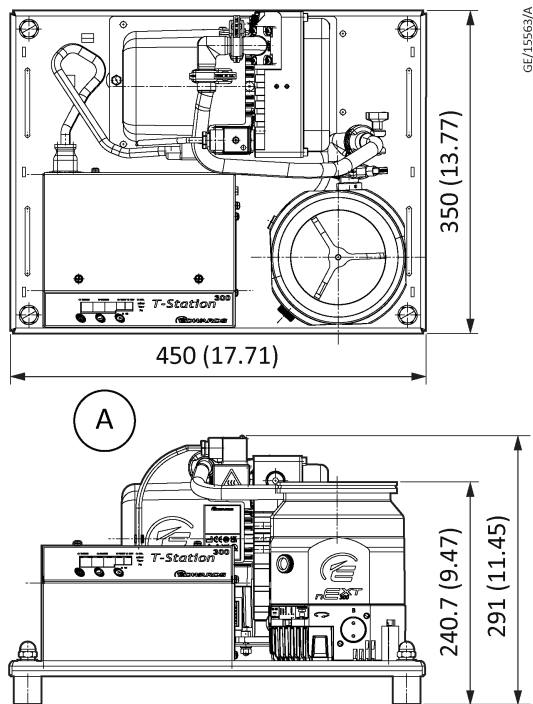
**Figure 4** Dimensions (T-Station with mXDS3s backing pump option)

### 3.3 Pump performance data

**Table 3** Pump performance data - nEXT300

Parameter	nEXT300D ISO100	nEXT300D CF100
Inlet pumping speed:		
▪ Nitrogen	300 ls <sup>-1</sup>	300 ls <sup>-1</sup>
▪ Helium	340 ls <sup>-1</sup>	340 ls <sup>-1</sup>
▪ Hydrogen	280 ls <sup>-1</sup>	280 ls <sup>-1</sup>
Inlet compression ratio:		
▪ Nitrogen	> 1 x 10 <sup>11</sup>	> 1 x 10 <sup>11</sup>
▪ Helium	1 x 10 <sup>6</sup>	1 x 10 <sup>6</sup>
▪ Hydrogen	5 x 10 <sup>4</sup>	5 x 10 <sup>4</sup>
Ultimate pressure*	< 6 x 10 <sup>-8</sup> mbar	< 5 x 10 <sup>-10</sup> mbar

\* Ultimate pressure 48 hours after bakeout for CF version and without bakeout for ISO version with 2-stage rotary vane backing pump.

### 3.4 Pumped media



#### **WARNING: DANGEROUS GASES**

Risk of injury or damage to equipment. Vent dangerous gases and gas mixtures safely. Do not expose people to these gases. If pumping hazardous gases or vapours, observe the safety recommendations of the supplier of the gas/vapour.



#### **WARNING: RISK OF EXPLOSION**

Risk of injury or damage to equipment. Do not use the pump to pump pyrophoric or explosive gas mixtures as it is not suitable for this purpose. The pump and its connections are not designed to contain an explosion.



#### **WARNING:**

Risk of injury or death of people. Do not expose any part of the human body to the vacuum.



#### **CAUTION: CONDENSABLE MEDIA**

Risk of damage to equipment. Do not use the pump to pump particulates or condensable media. Deposition may occur within the pump which will degrade pump performance and reduce the pump life.



#### **CAUTION: FAILURE OF PUMP**

Risk of damage to equipment. Do not use the pump to pump gases containing more than 20% oxygen. This will cause the lubricant to polymerise and the pump to fail prematurely.

The turbo pump is designed to pump the following residual gases normally used in high vacuum systems:

- Air
- Carbon monoxide
- Neon
- Ethane
- Methane
- Nitrogen
- Krypton
- Argon
- Propane
- Carbon dioxide
- Helium
- Hydrogen
- Butane

The pump can be used to pump oxygen and water vapour, subject to the following conditions:

- Oxygen - When the pump is purged by an inert gas, oxygen can be pumped at concentrations above 20% by volume. Refer to the nEXT pump instruction manual (B80000880) for purge gas specification. However, if the pump is not purged, the oxygen concentration must be less than 20% by volume.
- Water vapour - Ensure that vapour does not condense inside the pump.

To pump a gas not in the list above, contact the supplier for advice. Failure to contact the supplier may invalidate the warranty on the pump. The pump is not suitable for pumping aggressive or corrosive gases.

 **Note:**

*Concentrations of gases may be modified by the compression of the pump.*

### 3.5 Venting gas specification and vent control data

Although the pump may be vented to atmosphere, high relative humidity of the air may greatly increase the subsequent pump down time. To reduce pump down times the pump should be vented with dry, clean gases.

Refer to the nEXT pump instruction manual (B80000880) for the vent valve connection. Refer to [Vent valve screen](#) on page 32 for configuring the venting options.

*Table 4 Vent gas specification and vent control*

Vent gas specification and control	Reference data
Vent gas	Dry air, nitrogen, argon or other inert gases
Maximum dew point at atmospheric pressure	-22 °C
Maximum size of particulates	1 µm
Maximum concentration of oil	0.1 parts per million
Recommended time for rotational speed to reach 50%	> 15 seconds
Maximum allowed rate of pressure rise	Refer to <a href="#">Figure: Maximum allowed rate of pressure rise during venting: pressure against time (pump initially at full speed)</a>
Maximum allowable vent gas supply pressure	1 bar (gauge), 14.5 psig, 2 x 10 <sup>5</sup> Pa

**Figure 5** Max allowed rate of pressure rise during venting: pressure against time (pump initially at full speed)

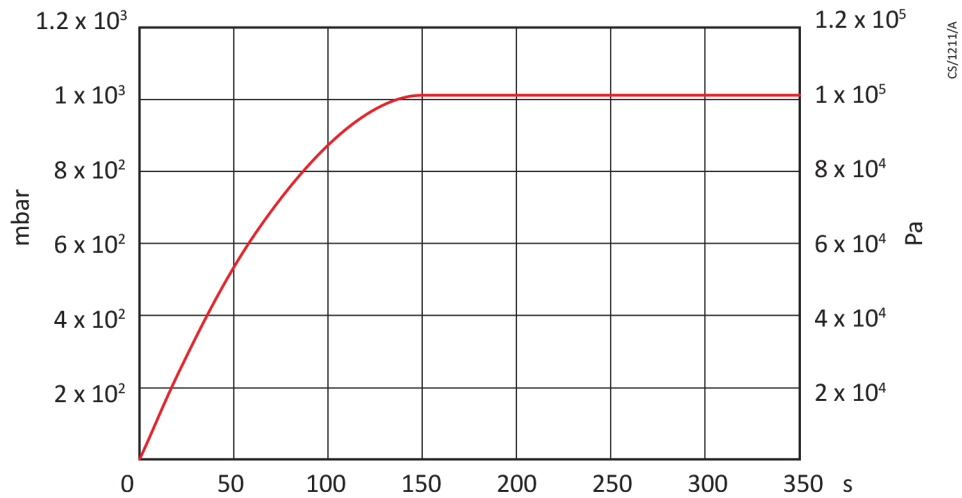

### 3.6 Materials exposed to gases pumped

The following materials and component types are exposed to the gases pumped:

- aluminium alloys
- stainless steels
- fluoroelastomer and nitrile O-rings
- hydrocarbon lubricant
- felt
- rare earth magnets
- silicon nitride
- carbon fibre reinforced epoxy resin
- fire retardant polypropylene
- polyamide
- PVC

### 3.7 Electrical connections

*Table 5 Electrical connections*

Parameter	Value
Electrical supply	
▪ Inlet plug type	IEC60320
▪ Integral fuse rating	10 A Type T, 20 mm
Backing pump	
▪ Outlet socket type	IEC60320
Turbomolecular pump	
▪ Connector type	15-way sub-miniature 'D' type socket



Parameter	Value
▪ Power supply	24 V d.c. nominal
▪ Maximum power rating	160 W
Active gauge	
▪ Connector type	RJ45 8-way
▪ Power supply	24 V d.c. nominal
▪ Maximum power rating	4 W

**Figure 6** Pin connections for 15-way sub-miniature 'D' type socket

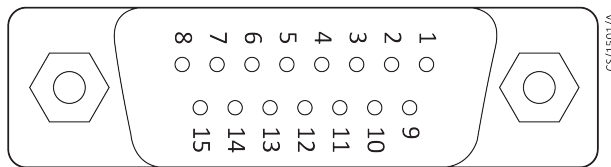

**Table 6** Turbo pump connector pin-out

Pin	Function
1	Power supply positive
2	Signal common
3	Start signal output
4	RS232 Tx
5	Serial enable output
6	Power supply positive
7	RS232 Rx
8	Power supply common
9	Speed signal input
10	Screen
11	Power supply positive
12	Screen
13	Power supply common
14	Power supply common
15	Normal signal input

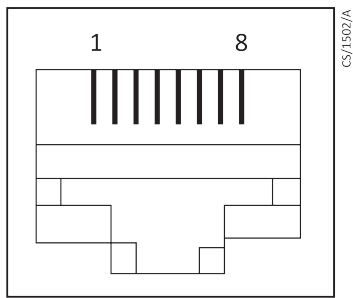
**Figure 7** Pin connections for an 8-way RJ45**Table 7** Active gauge connector pin-out

Pin	Function
1	Power supply positive
2	Power supply common
3	Signal input
4	Identification
5	Signal common
6	Control line 1
7	Control line 2
8	Not connected

### 3.8 Electrical data

If the pumping system uses an E2M1.5, the motor start up current is drawn for less than one second, so slow-blow fuses must be used to prevent unnecessary fuse failure when the pump starts. If using the pump at temperatures lower than 12 °C (53.6 °F), the start up current will be drawn for longer, this may cause the motor thermal overload device to open.

**Table 8 Electrical data**

Supply voltage 50/60 Hz	Current (A)		Power (W)
	Full load	Start	
XDD1 / nEXT300			
100	3.5	-	350
120	2.9	-	
200	1.75	-	
230	1.52	-	
E2M1.5 / nEXT300			
100	5.1	13.6	510
120	4.25	12.0	
200	2.55	6.4	
230	2.22	5.7	
mXDS3s			
100V	5.6A	-	560
115V	4.87A	-	
200V	2.8A	-	
230V	2.44A	-	

## 4. Installation

### 4.1 Installation safety



#### **WARNING: INSTALLATION SAFETY**

**Risk of injury or damage to equipment. Follow the safety instructions and take note of all appropriate precautions.**

- When referring to a manual supplied as a Supplementary Publication, all of the WARNING and CAUTION instructions in the manual must be obeyed.
- A suitably trained and supervised technician must install the pumping system.
- Check that all the required parts are available and of the correct type before commencing work.
- Ensure that the installation technician is familiar with the safety procedures which relate to the products pumped.
- Wear the appropriate safety clothing when coming into contact with contaminated components.
- Isolate the other components in the system from the electrical supply so that they cannot be operated accidentally.
- Do not reuse O-rings and co-seals if they are damaged.
- Dispose of components, grease and oil safely (refer to *Disposal* on page 44).
- Take care to protect sealing faces from damage.
- Leak testing the system after installation is complete to ensure optimum vacuum performance is recommended.

### 4.2 Unpack and inspect

1. Remove the outer cover and all packing materials. Remove the protective covers from the inlet and outlet ports and inspect the system for any damage.
2. If the pumping system is damaged, notify the supplier and the carrier in writing within three days, state the item number of the pumping system together with the order number and the supplier's invoice number. Do not use the pump if it is damaged.
3. Retain all packing materials for inspection.
4. Check that the package contains the items listed in . If any of these items are missing, notify the supplier in writing within three days.
5. If the pump is not to be used immediately, replace the protective covers and store in suitable conditions as described in *Storage* on page 43.

*Table 9 Checklist of items*

Quantity	Description	Check
1	T-Station 300	<input type="checkbox"/>
1	CD instruction manual P45000000	<input type="checkbox"/>
1	Ultragrade 15 oil 1 litre (supplied with E2M1.5 only)	<input type="checkbox"/>

Quantity	Description	Check
1	Inlet seal (either trapped O-ring, co-seal or copper compression gasket suitable for the inlet flange type)	<input type="checkbox"/>
4	Rubber spacers for bench top fixing 4 pcs	<input type="checkbox"/>

### 4.3 Locate the pumping system



#### WARNING: HEAVY OBJECT

Risk of injury or damage to equipment. Heavy objects can cause muscle strain or back injury. The mass of the pumping system will differ depending on the model supplied. Make sure that 2 person lift the pump together. Do not use crane to lift the pumping system.



#### WARNING: KINETIC ENERGY

Risk of injury or damage to equipment. The turbo pump used on the T-Station 300 stores a large amount of kinetic energy when it is running at full speed. In the unlikely event of a malfunction (rotor seizure), the stored energy could cause a slight movement of the T-Station 300 platform. If the T-Station 300 is operating on a bench top, taking the following steps is advised: (a) Position the T-Station 300 at least 10 to 15 cm away from the edge of the bench top and adjacent devices and/or (b) Tether or fix the T-Station 300 to the bench top. Refer to [Bench top fixing](#) on page 21.



#### CAUTION: OVERHEATING

Risk of damage to equipment. When locating the pumping system, care should be taken not to restrict the ventilation grid located under the base of the system. Failing to observe this may result in overheating of the turbomolecular pump.

### 4.4 Bench top fixing

#### Note:

*Straps or screws cannot be provided as the best type fixing for the customer bench top location cannot be determined. Sourcing or fabricating these fixings locally is recommended.*

#### 4.4.1 Bench top fixing with straps

1. Locate the pumping system on your bench. We recommend to locate the system at least 15 cm from the bench edge.
2. Lead the straps through prepared windows in base plate. It is necessary to use 2 straps with safety load limit of at least 2500 kg to ensure that the system is fixed securely. If you will use 2 straps but only in one string, the safety load must be minimum 5000 kg.

Figure 8 Bench top fixing with straps

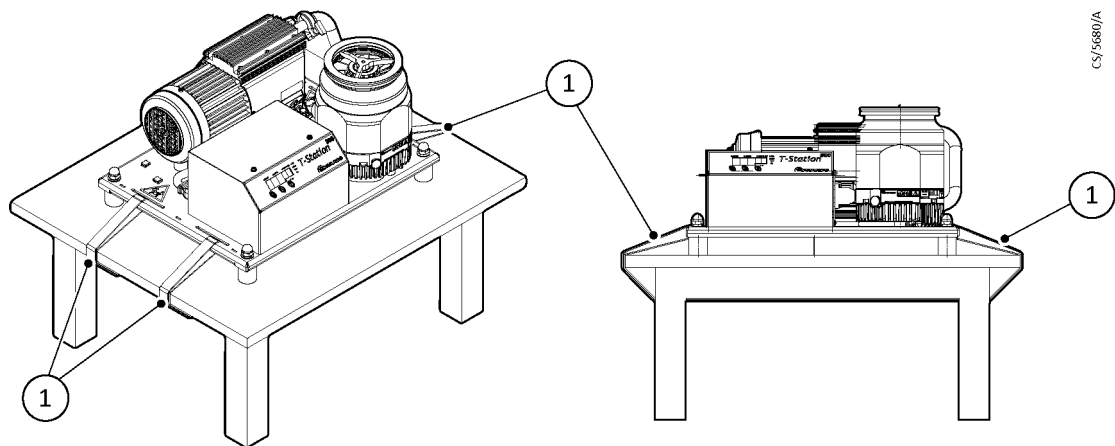

1. Straps

#### 4.4.2 Bench top fixing with screws

1. Dismantle the 4 rubber feet.
2. Copy holes from base plate on your bench.
3. Drill 11 mm holes in your bench .
4. Place the pumping system on supplied spacers.
5. Tighten the system by your own high tensile screws of appropriate length.

#### 4.5 Fill the pump with oil

If the pumping system uses an E2M1.5 rotary vane pump, it must be filled with the correct quantity of oil (supplied) before operating the equipment. For further information refer to the EM Rotary Vane Pump manual A37132880.

Fill the pump with oil as follows:

1. Remove the oil filler plug.
2. Pour oil into the pump until the oil level just reaches the MAX mark on the bezel at the top of the sight glass. If the oil level goes above the MAX mark, remove the drain plug and drain the excess oil from the pump.
3. After a few minutes, recheck the oil level. If the oil level is now below the MAX mark, pour more oil into the pump.
4. Refit the oil filler plug. Tighten the plug firmly by hand. Do not over tighten.

#### 4.6 Connect to the vacuum system



##### **WARNING: POWER SUPPLY TO PUMP**

Risk of injury or damage to equipment. Connect the turbo pump inlet to the vacuum system before applying power to the pumping system. This will ensure that the pump cannot operate accidentally causing injury.

**WARNING: TOPPLE HAZARD**

Risk of injury or damage to equipment. If installing the vacuum system directly onto the pumping system, the weight of the system must be no more than 10 kg and the centre of gravity must be positioned laterally within the bounds of the base plate. If this is not the case, the vacuum system must be supported to ensure that the pumping system does not topple.

1. The turbo pump can be securely fixed to the vacuum system via the inlet flange. Make sure that the pump inlet and all components fitted to the pump inlet are clean and dust-free. If the pump inlet is not kept clean, the pump down time may be increased.
2. If the pump has a CF flange, use the copper compression gasket supplied with the pump and use a full complement of bolts to connect the inlet flange of the pump to the vacuum system.
3. If the pump has an ISO flange, use a minimum of four claw clamps (each torqued to 10 Nm) to connect the inlet flange of the pump to the vacuum system. Alternatively, use a rotatable collar and the combined inlet screen and trapped O-ring supplied with the pump to connect the inlet flange of the pump to the vacuum system, use a full complement of bolts with the rotatable collar.
4. All inlet flange bolts must be re-tightened once the system is under vacuum. Ensure that no torques or other forces are transmitted to the pump from the vacuum system or the associated pipelines.

## 4.7 Connect to the exhaust extraction system

**WARNING: DANGEROUS GASES**

Risk of injury or damage to equipment. Vent dangerous gases and gas mixtures safely. Do not expose people to these gases. If pumping hazardous gases or vapours, observe the safety recommendations of the supplier of the gas/vapour.

The exhaust system must be configured so that the maximum pressure at the pump outlet does not exceed 0.5 bar gauge (1.5 bar absolute,  $1.5 \times 10^5$  Pa) at full pump throughput.

1. Make sure that the exhaust pipeline cannot become blocked.
2. If using an exhaust isolation valve, make sure the pump cannot be operated with the valve closed.

 **Note:**

*This section applies to both E2M1.5 and mXDS3s versions.*

## 4.8 Connect the electrical supply

**WARNING: ELECTRICAL INSTALLATION SAFETY**

Risk of injury or damage to equipment. Ensure that the electrical installation of the pump conforms with all local and national safety requirements. It must be connected to a suitably fused and protected electrical supply with a suitable earth point.

**CAUTION: ELECTRICAL INSTALLATION SAFETY**

**Risk of damage to equipment. Always make the electrical connections to the pumping system after the equipment has been installed on the vacuum system. Always disconnect the electrical supply from the pumping system before removing the equipment from the vacuum system.**

Check that the electrical supply is suitable for this equipment. Refer to [Table: Electrical data](#) for the electrical requirements for this equipment.

Make the electrical connection to the pumping system using a cable fitted with an IEC60320 connector.

A range of suitable cables is available from the supplier.

## 4.9 Configure the pumping system

As supplied from the factory, the pumping system will control the system as follows:

If system start is selected:

- The TAV vent valve will close.
- The backing pump will turn on.
- The turbomolecular pump will start accelerating up to full rotational speed.

If system off is selected:

- The backing pump will turn off.
- The turbomolecular pump drive will turn off and the pump will start to decelerate.
- The TAV vent valve will open fully from 50% of full rotational speed.

### 4.9.1 Turbo pump delay

The pumping system can be configured to delay the turbo pump after the backing pump has started.

Refer to [Turbo setpoint screen](#) on page 33. The delay is helpful to prevent the turbomolecular pump from accelerating under high pressure for a prolonged period if the volume being pumped is greater than 2 litres. This option is especially useful if the pumping system uses an XDD1 diaphragm pump.

The [Figure: Turbomolecular pump start delay with XDD1 diaphragm pump](#) shows the recommended delay period for a turbo / XDD1 pump combination.

\* This operation refers to systems which have been fitted with our TAV vent valve (optional accessory). For more vent options refer to [Vent valve screen](#) on page 32.

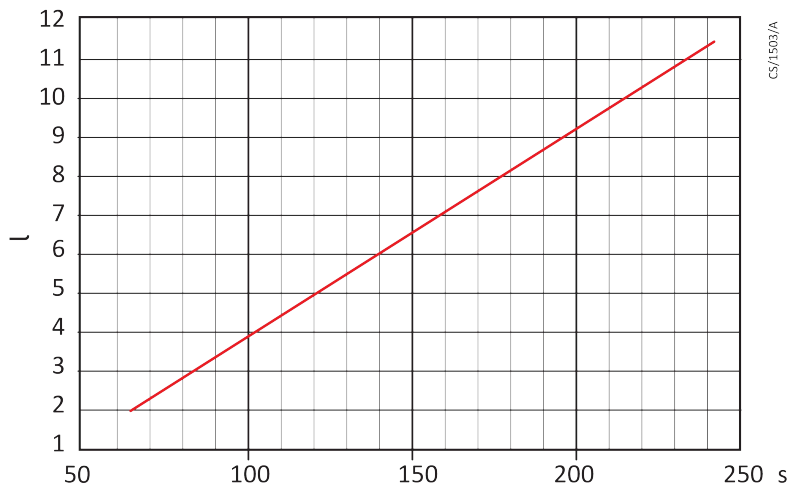

**Figure 9** Turbomolecular pump start delay with XDD1 diaphragm pump

#### 4.9.2 Connect a vacuum gauge

A single compatible active gauge can be fitted to the pumping system.

Fit the gauge using an our active gauge cable into the gauge connector located on the side of the controller housing. For active gauge control and set up refer to [Gauge screen](#) on page 31.

The following are our active gauges which are suitable for use with the pumping system:

- APG100 Active pirani vacuum gauge
- APGX-H Active linear convection gauge
- AIM-X Active inverted magnetron gauge
- ASG Active strain gauge
- WRG Wide range gauge

## 5. Commission the system

After installing the T-Station 85, the system must be tested.

Use the following procedure to test the system:

1. Make sure that all the electrical connections are secure.
2. Switch on the electrical supply and the exhaust extraction system (if available).
3. To operate the system press the START/STOP key. Check that the equipment operates as described in .
4. Check that the turbo pump reaches normal speed. If the pump inlet is valved or capped off, it should take approximately 100 - 150 seconds for the turbo to reach normal speed. If a vacuum chamber is attached to the pump inlet, this time may take longer.
5. To turn OFF the system, press the START/STOP key followed by the ENTER key to confirm. Check that the equipment closes down as described in .

For full operational details and how to navigate using the front panel control key pad refer to [Menu structure](#) on page 29.

### 5.1 Installation checklist

You must check the installation before you commission or start the system.

1	The pumping system is securely mounted to a robust structure.	<input type="checkbox"/>
2	The cooling airflow is unobstructed with sufficient gap between the T-station and the bench.	<input type="checkbox"/>
3	All electrical cables are undamaged and correctly connected.	<input type="checkbox"/>
4	Oil has been applied to the wet primary pump variant E2M1.5, if fitted.	<input type="checkbox"/>
5	The turbomolecular pump plastic cover has been removed and the inlet is securely connected to the system requiring evacuation.	<input type="checkbox"/>
6	The blanking cap on the primary pump has been removed and any valves in the exhaust line are open.	<input type="checkbox"/>
7	The on button of the backing pump is in the on position "I".	<input type="checkbox"/>
8	The ambient conditions and gases to be pumped are according to the instruction manual.	<input type="checkbox"/>
9	The belows is not in touch with anything around .. due for mXDS3s, if fitted	<input type="checkbox"/>

### 5.2 Test the system

Use the following procedure to test the system:

1. Make sure that all the electrical connections are secure and your supply voltage corresponds to T-station supply voltage on rating label which is on the top of controller box.
2. Switch on the electrical supply and the exhaust extraction system (if available).
3. To operate the system press the START/STOP key. Check that the equipment operates as described in [Turbo screen](#) on page 30.

4. Check that the turbo pump reaches normal speed. If the pump inlet is valved or capped off, it should take approximately 100 - 150 seconds for the turbo to reach normal speed. If a vacuum chamber is attached to the pump inlet, this time may take longer.
5. To turn OFF the system, press the START/STOP key followed by the ENTER key to confirm. Check that the equipment closes down as described in [Turbo screen](#) on page 30.

For full operational details and how to navigate using the front panel control key pad refer to [Menu structure](#) on page 29.

When applying power to the pumping system all LEDs in the display will light for 2 seconds to confirm operation. The software version will then be displayed for a further 2 seconds. The software version is required when you contact us for support regarding the pumping system.

## 6. Operation

### WARNING: ROTATING PARTS



Risk of injury or damage to equipment. Do not attempt to move the pumping system while the turbo pump is rotating. Doing so may cause severe damage to the pump and could cause injury.

### CAUTION: OPERATIONAL SAFETY



Risk of damage to equipment. To familiarise yourself with the vacuum pumps installed on the pumping system, it is advisable to read the relevant instruction manuals refer to [General description](#) on page 8.

### 6.1 Control panel description

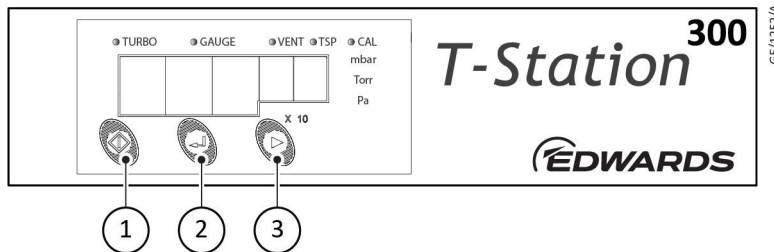

1. Start/Stop
2. Enter
3. Next

**Table 10** Front panel symbols and their functions

Key pad symbol	Name	Function
1	START/STOP	Turns the pumps on and off. Returns to turbo menu screen.
2	ENTER	Selects or confirms current menu option. Controls active gauges.
3	NEXT	Moves to next menu. Scrolls through menu options.

The LEDs along the top of the pumping system display indicate which menu screen is currently being shown on the numeric display. To move to the next menu item press the NEXT key and to return to the turbo menu screen press the START/STOP key. The available items are listed in order in [Table: Menu items](#).

**Table 11 Menu items**

Turbo screen
Gauge screen
Vent valve screen
Turbo setpoint (TSP) screen
Calibrate gauge screen
Units screen

## 6.2 Menu structure

*Figure: Menu structure* shows the view screen shortcuts and menu structure for the pumping system control display. They also give an indication as to where buttons will take you within the menu layout.

Figure 10 Menu structure

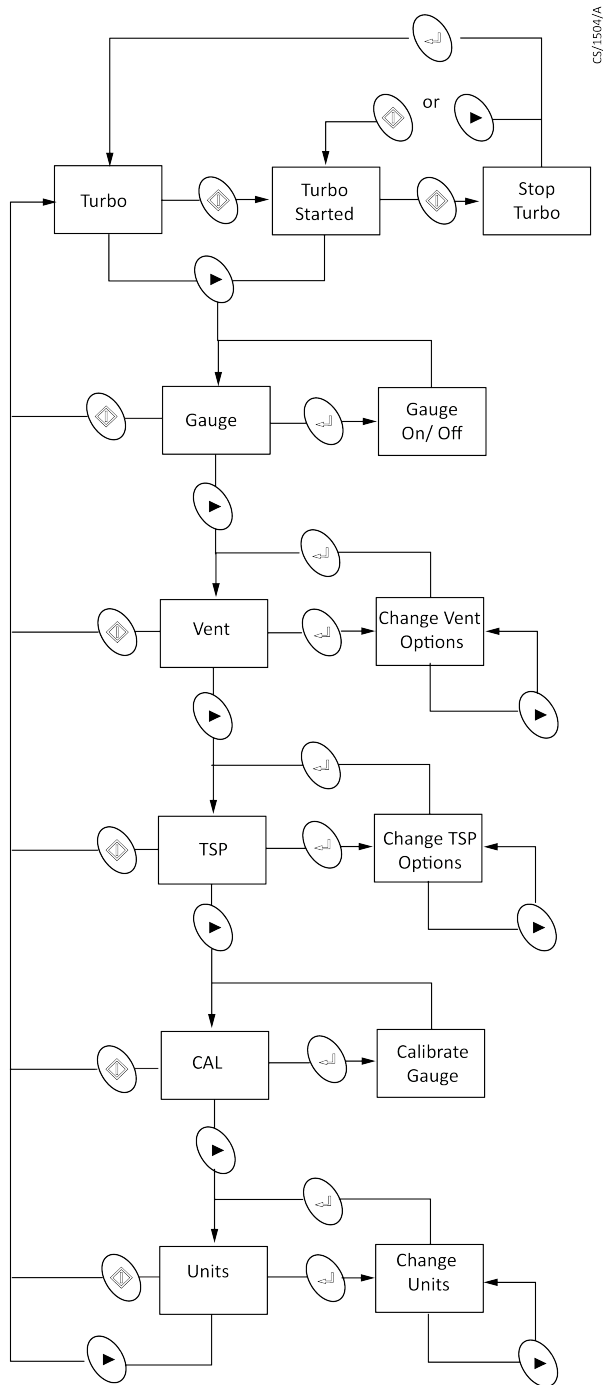

### 6.2.1 Turbo screen

When the turbo screen is selected, the turbo LED is lit and the speed of the turbomolecular pump is displayed in percentage of full speed.

If no turbo pump is connected the display shows "---".

**Figure 11** Turbo screen

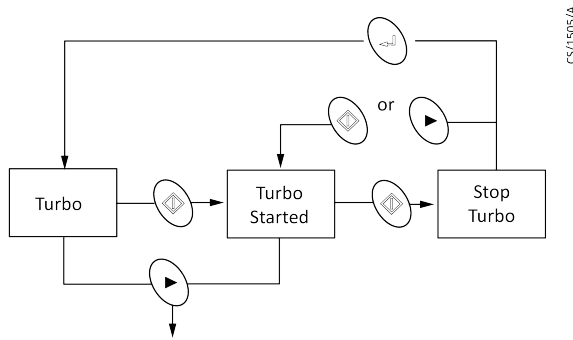

**Start the pump with the turbo screen**

When you push the START/STOP key, both the turbo and backing pumps start. The display shows the turbo pump is accelerating by flashing the top left portion of the percentage sign. When the turbo pump reaches normal speed (> 80% default) the percentage sign stops flashing and remains steady.

If a Turbo Set-Point (TSP) has been set, only the backing pump starts when you push the START/STOP key. The TSP LED flashes until the setpoint has been reached. Once the setpoint has been reached the turbo pump starts and the TSP LED turns OFF. If no turbo setpoint has been set, the TSP LED remains OFF.

**Stop the pump with the turbo screen**

1. To stop the pumps press the START/STOP key, the display will show "Stop" for three seconds.
2. Press the ENTER key within that time to stop the pumps. If the ENTER key has not been pressed, or the START/STOP or NEXT keys are pressed, the display shows the turbo pump speed and the pumps remain running.

When the turbo pump is decelerating the bottom right portion of the percentage sign flashes until the pump has completely stopped.

**Table 12** Turbo screen key actions

Keys	Short press	Long press
START	START the turbo, or initialise turbo STOP sequence, or cancel turbo STOP, or force turbo STOP when in error	-
ENTER	Acknowledge turbo STOP	Fault code display when in error
NEXT	Go to gauge screen, or cancel turbo STOP	Scroll through menu screens

**6.2.2 Gauge screen**

When the gauge screen is selected, the gauge LED is lit and the gauge pressure reading is displayed in the selected units.

If no gauge is connected the display shows "---".

### Connect a gauge

When a gauge is first connected the display shows "ID" followed by a number to identify the new gauge.

If the gauge is an Active Strain Gauge (ASG), the display then goes to ASG range select, otherwise the display reverts to showing the pressure reading. If the gauge type is not supported the display shows "???". When no gauge is connected the display shows "---".

Figure 12 Gauge screen

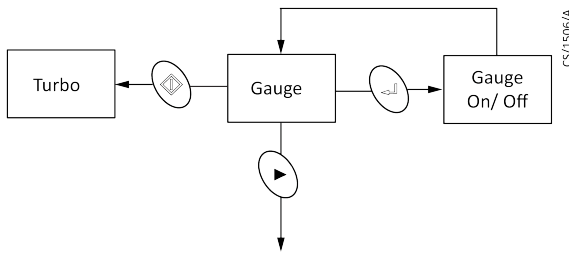

### ASG range select

When an ASG is connected the display changes to select the ASG range. 1000 mbar is assumed by default, and the display flashes "1.0<sup>3</sup>".

Press the NEXT key to select between 1000 and 2000 mbar, then press the ENTER key to confirmed the selection.

### Gauge ON/OFF control

Gauges which support ON/OFF control (e.g. AIM gauges) can be turned ON and OFF using the ENTER key.

When first connected the gauge is in the OFF state and the display shows "OFF". When the gauge is turned on the display will show "Str" whilst the gauge is starting up, and will then display pressure.

Table 13 Gauge screen key actions

Keys	Short press	Long press
START	Go to turbo screen	-
ENTER	ON/OFF control of supported gauge or acknowledge error	-
NEXT	Go to vent control screen	Scroll through menu screens

## 6.2.3 Vent valve screen

If a TAV solenoid vent valve is connected to the turbo pump module the operation of the valve is controlled by the vent valve screen.

When the vent valve screen is selected, the vent LED is lit and the current vent valve control setting is displayed. The default is "50%". The vent valve screen is not available if the turbo pump is running.

1. Select the appropriate setting for either normally open or normally closed vent valve.



2. To change the vent valve setting press the ENTER key, then use the NEXT key to choose between 50%, CtrlId and FAN.
3. Press the ENTER key again to confirm the selection.

**Table 14 Vent valve screen**

50 <sup>no</sup>	Normally open vent valves. Vent valve opens fully when the speed of the turbo pump drops below 50% full rotational speed.
Ctl <sup>no</sup>	Normally open vent valves. Controlled venting from 100% to 50% full rotational speed, vent valve opens fully below 50%.
Fan	Normally open vent valves. The vent valve connection on the turbo pump is permanently powered so that the vent valve will remain closed. This can also be used to provide power to an air cooler (for example, ACX75).
Off	Normally closed vent valves. The vent valve connection on the turbo pump is permanently disabled so the vent valve will remain closed.
50 <sup>nc</sup>	Normally closed vent valves. The vent valve will open when the speed of the turbo pump has dropped below 50% during stop but not fail conditions.
Ctl <sup>nc</sup>	Normally closed vent valves. Controlled venting from 100% to 50% full rotational speed, vent valve opens fully below 50% during stop but not fail conditions.

**Figure 13 Vent valve screen**

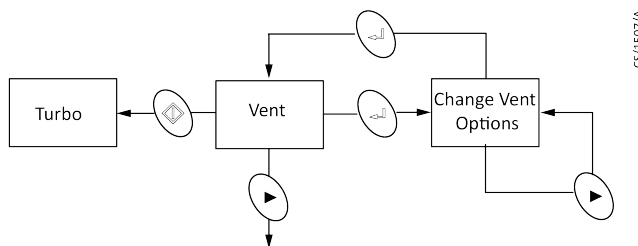

**Table 15 Vent valve screen key actions**

Keys	Short press	Long press
START	Go to turbo screen	-
ENTER	Enter edit mode, or confirm selection	-
NEXT	Next vent option, or go to TSP control screen	Scroll through vent options in edit mode or scroll through menu screens

### 6.2.4 Turbo setpoint screen

The turbo setpoint screen is used to configure the start delay of the turbo pump.

When the turbo setpoint screen is selected, the TSP LED is lit and the current setpoint is displayed. The default is "OFF". The turbo setpoint menu is not available if the turbo pump is running or the selected units are volts.

1. To change the turbo setpoint press the ENTER key, then use the NEXT key to choose between off, time delay and pressure setpoint.

2. Press the ENTER key again to confirm the selection.
3. When time delay is selected the display will show the delay time in seconds. The default time is 120 seconds. This means that the turbo pump will start after a delay of 120 seconds from when the START key is pressed. To change the value of the delay time press and hold the ENTER key to start number entry mode.
4. If an active gauge is connected to the system the pressure setpoint can be used to start the turbo pump once the pressure has fallen below the setpoint value. When pressure is selected the display shows the setpoint pressure. The default pressure is 5.00 mbar shown as an exponential. To change the pressure setpoint, press and hold the ENTER key to start number entry mode.

 **Note:**

*If the turbo setpoint is set to pressure but a gauge is not connected the turbo pump will not start.*

**Figure 14** Turbo setpoint screen

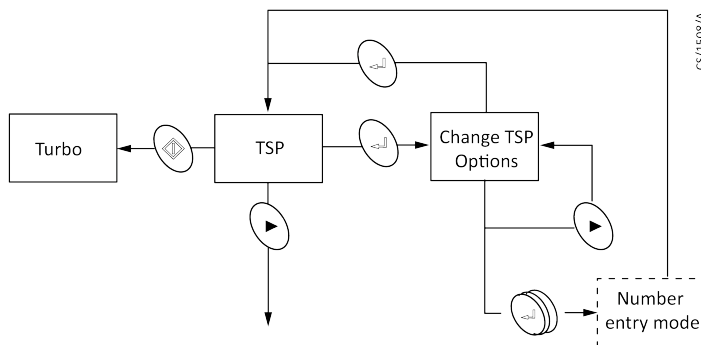

### Number entry mode

When the ENTER key is pressed and held on either the time or pressure option, number entry mode is entered. The first digit starts flashing and the time or pressure can be edited.

1. Press the NEXT key to adjust the value, then press the ENTER key to confirm the digit and then move on to the second digit, which is adjusted similarly. The ENTER key confirms the digit and then moves to the final digit of the time setpoint or the exponent of the pressure setpoint. The exponent of the pressure setpoint is adjusted as a single value in the range - 10 to + 6.
2. The final press of ENTER confirms the complete number and returns to showing the setpoint value. The TSP is set after the complete number is entered.

**Figure 15** Turbo setpoint number entry mode

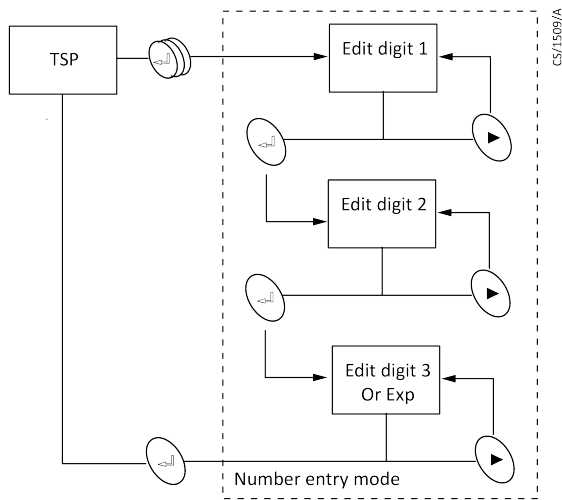

**Table 16** Turbo setpoint screen key actions

Keys	Short press	Long press
START	Go to turbo screen	-
ENTER	Enter edit mode, or confirm selection	Enter number entry mode
NEXT	Next TSP option, next number or go to gauge calibration screen	Scroll through TSP options in edit mode, scroll through numbers in number entry or scroll through menu screens

### 6.2.5 Calibrate gauge screen

When the calibrate gauge screen is selected, the gauge LED and the CAL LED are lit together. The numeric display is blank. The calibrate gauge menu is not available for gauges which do not support calibration.

When the ENTER key is pressed the action depends on gauge type:

**WRG or APGX:** The calibration command is sent to the gauge and the display shows "CALd" for 3 seconds.

**ASG:** The calibration functions as a zero offset adjustment. The pressure currently displayed is saved as the zero offset and is subtracted from all future readings. The display shows "CALd" for 3 seconds to confirm the action. The offset adjustment can be cancelled by pressing the ENTER key again. The display shows "OFF" for 3 seconds to confirm that the offset adjustment has been removed.

Figure 16 Calibrate gauge screen

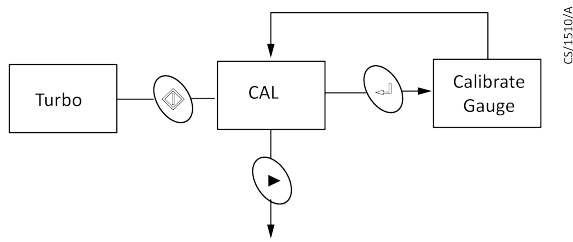

Table 17 Calibrate gauge screen key actions

Keys	Short press	Long press
START	Go to turbo screen	-
ENTER	Calibrate gauge	-
NEXT	Go to units screen	Scroll through menu screens

### 6.2.6 Units screen

When the units screen is selected, the menu LEDs are unlit and the currently selected units LED is lit. The numeric display is blank.

To change the units press the ENTER key and use the NEXT key to choose between mbar, Torr, Pa and voltage. Press the ENTER key again to confirm the selection. Note that when voltage is selected the display shows " 0.000".

When the units are changed, the setpoint values will be converted to the new units. For example, if a setpoint threshold is entered as  $1.0 \times 10^{-3}$  mbar and the units are changed to Torr, then the value will be displayed as  $7.5 \times 10^{-4}$  Torr.

Figure 17 Units screen

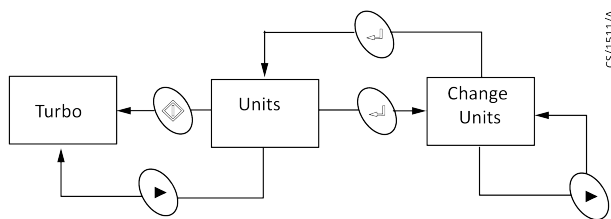

Table 18 Units screen key actions

Keys	Short press	Long press
START	Go to turbo screen	-
ENTER	Enter edit mode, or confirm selection	-
NEXT	Next units option, or go to turbo screen	Scroll through units in edit mode, or scroll through menu screens

## 6.3 Gas ballast control

To pump high vapour loads, gas ballast can be delivered into the pump to prevent a condensation of the vapour carried by the pumped gases.

### E2M1.5:

Use the gas ballast control to change the amount of air (or inert gas) introduced into the low vacuum stage of the pump. This will prevent the condensation of vapours in the pump. The condensates can contaminate the oil.

Close the gas ballast control to pump dry gases and to achieve ultimate vacuum.

Turn the gas ballast control six turns anti-clockwise to open it fully. Open the gas ballast control to pump high concentrations of condensable vapour.

When operating the pump with the gas ballast control open, there will be an increased rate of oil loss from the pump.

### mXDS3s:

Air can be introduced to the low vacuum stages through the gas ballast control (refer to [Figure: General view of the pumping system](#) on page 9). The gas ballast plug can be unscrewed:

- By one revolution counterclockwise - in case of small performance reduction or doubts,
- Or removed completely - in case of significant performance reduction.

Position of the gas ballast control can be changed when the pump is either off or operating.

#### Note:

*If the pump is used on systems with very low flow or with high humidity, then to help to clear the vapours and tip seal dust from the pump, we recommend to use gas ballast more frequently (approximately 0.5 hour every day).*

## 6.4 Electrical supply failure



### **WARNING: IMPELLER SPIN**

**Risk of injury or death. If the power supply fails when the pump is running, the impeller could continue to spin for approximately 10 minutes. The control circuit may not give any indication that the impeller is still running.**

If the electrical supply to the pumping system fails when the turbo pump is rotating, the motor of the turbo pump is used as a generator. The regenerated power is used to maintain the control system and the display. The regenerated power is not used to maintain the pumping system control system or the display.

When power to the control system is lost, no indication will be given about pump rotational speed, yet the impeller may still be turning.

The system will not restart when the power is reinstated.

## 7. Maintenance

### 7.1 Maintenance safety



#### **WARNING: MAINTENANCE SAFETY**

**Risk of injury or damage to equipment. Follow the safety instructions and take note of all appropriate precautions.**

- When referring to a manual supplied as a Supplementary Publication, all of the WARNING and CAUTION instructions in the manual must be obeyed.
- A suitably trained and supervised technician must maintain the pumping system.
- Allow the system to cool (so that it is at a safe temperature for skin contact) before starting maintenance work. Make sure the system is switched off in case the thermal overload device restarts the system.
- Check that all the required parts are available and of the correct type before starting work.
- Ensure that the maintenance technician is familiar with the safety procedures which relate to the pump oil and the products processed by the pumping system.
- Isolate the system and other components from the electrical supply so that they cannot be operated accidentally.
- Do not reuse O-rings and seals if they are damaged.
- Dispose of components, grease and oil safely (refer to [Disposal](#) on page 44).
- Protect sealing faces from damage.
- Leak testing the system is recommended after maintenance. Seal any leaks found if any vacuum or exhaust pipeline connections have been disconnected.

### 7.2 Maintenance plan



#### **WARNING: FAILURE OF SCREWS**

**Risk of injury or damage to equipment. If the turbo pump is removed from the pumping system, it is important to retain and reuse the same fixing screws. If any of these screws are lost or cannot be used, the following type M8 x 16-18 mm CAP HD high tensile class 12.9 must be used. If this warning is ignored and the turbo pump seizes, the stored energy in the turbo pump may cause some or all of the screws to fail. This may result in the turbo pump being ejected from the pumping system.**

Refer to Associated publications on page 2 for minimum maintenance operations necessary to maintain the pumping system in normal use.

More frequent maintenance may be necessary if the pumping system has been used to pump corrosive or abrasive gases and vapour. If necessary, adjust the maintenance plan according to your experience.

### **7.3 Inspect the hoses, pipelines and connections**

1. Inspect all of the electrical connections and check that they are secure. Tighten any loose connections.
2. Inspect all of the electrical cables and check that they are not damaged and have not overheated. Replace or repair any damaged or overheated cable.
3. Inspect all of the vacuum and exhaust connections and check that they are secure. Tighten any loose connections.
4. Inspect all of the vacuum and exhaust pipelines and check that they are not corroded or damaged and that they do not leak. Replace or repair any corroded or damaged component and seal any leaks found.

### **7.4 Factory default settings**

Procedure to return the pumping system to the factory default settings.

1. Remove the mains power from the pumping system.
2. Press the NEXT key and hold it down whilst reapplying mains power. Continue holding down the NEXT key until "Err01" is displayed.
3. Remove and reapply mains power. The factory defaults will now be set.

## 8. Fault finding

Table 19 Fault finding

Condition
<i>The pumping system has failed to start</i> on page 40
<i>Ultimate pressure cannot be reached</i> on page 40
<i>The backing pump is noisy</i> on page 41
<i>The backing pump is leaking oil</i> on page 41
<i>The turbo pump is very noisy or there is excessive vibration or both</i> on page 41

<b>Fault</b>	<b>The pumping system has failed to start</b>
<b>Cause</b>	<b>The electrical supply fuse has blown</b>
Remedy	Replace the fuse. Refer to .
<b>Cause</b>	<b>The operating voltage is incorrect</b>
Remedy	Check the voltage supply matches the pumping system voltage requirements. Refer to the electrical rating label located at the rear of the pumping system.
<b>Fault</b>	<b>Ultimate pressure cannot be reached</b>
<b>Cause</b>	<b>Pressure is limited by water vapour</b>
Remedy	Bake the chamber or run the system for a duration until the vacuum improves.
<b>Cause</b>	<b>The vacuum gauges are contaminated</b>
Remedy	Clean or replace the vacuum gauges.
<b>Cause</b>	<b>Pumping speed is insufficient due to poor conductance between the pump and the gauge or the chamber is too large</b>
Remedy	Increase the conductance or reduce the volume.
<b>Cause</b>	<b>The backing pressure is greater than 10 mbar (<math>1 \times 10^3</math> Pa)</b>
Remedy	The backing pressure may be too high. Check for backing pipeline leaks. If the throughput is high, a larger backing pump may be required.
<b>Cause</b>	<b>The high vacuum area of the system is contaminated</b>
Remedy	Clean the high vacuum system.
<b>Cause</b>	<b>Check the rest of the system for leaks and contamination</b>
Remedy	If found, repair the leaks and clean the contamination.



<b>Cause</b>	<b>The inlet pressure is poor</b>
<b>Remedy</b>	If inlet pressure is poor, check the turbo pump for contamination and refer to the Troubleshooting section of the turbo pump manual. Leak test the pump. If the leak rate is greater than $1 \times 10^{-7}$ mbar l s <sup>-1</sup> ( $1 \times 10^{-5}$ Pa l s <sup>-1</sup> ), contact us or the supplier.
<b>Fault</b>	<b>The backing pump is noisy</b>
<b>Cause</b>	<b>The pump is noisy.</b>
<b>Remedy</b>	Refer to the Fault Finding section of the backing pump manual. See <a href="#">General description</a> on page 8.
<b>Fault</b>	<b>The backing pump is leaking oil</b>
<b>Cause</b>	<b>There is oil leak in the backing pump</b>
<b>Remedy</b>	Refer to the Fault Finding section of the backing pump manual. See <a href="#">General description</a> on page 8.
<b>Fault</b>	<b>The turbo pump is very noisy or there is excessive vibration or both</b>
<b>Cause</b>	<b>The turbo pump is noisy or vibrates during operation</b>
<b>Remedy</b>	Refer to the Troubleshooting section of the turbo pump manual. See <a href="#">General description</a> on page 8.

## 8.1 Error numbers

If an error is detected by the controller the display will show "Err" followed by a number.

Refer to [Table: Error numbers](#) for a description of the error together with likely causes and suggested remedies.

**Table 20 Error numbers**

<b>Error Number</b>	<b>Meaning</b>	<b>Possible cause/remedy</b>
Controller errors		
1	EEPROM error	The internal EEPROM checksum has failed. All user settings will revert to the factory default.
2	ID reference error	The reference used for identifying gauges is incorrect. Please remove all connected gauges, turn the electrical supply off and on, and wait for 30 seconds before reconnecting the gauges.
Gauge errors		
11	Gauge voltage too high	The voltage from a gauge is too high. The gauge may be defective.
12	Gauge voltage too low	The voltage from a gauge is too low. The gauge may be defective.

Error Number	Meaning	Possible cause/remedy
21	WRG Pirani failure	Errors specific to WRG. Refer to the WRG manual for details. Press the ENTER key to clear the error from the display once the fault has been corrected.
22	WRG magnetron short	
23	WRG striker fail	
24	WRG magnetron not struck	
25	APGX filament failure	Errors specific to APGX. Refer to the APGX manual for details. Press the ENTER key to clear the error from the display once the fault has been corrected.
26	APGX cal err	
27	APGXH tube not fitted	
<b>Pump errors</b>		
41	Turbo pump fault	Inspect the LEDs on the turbo pump module for status information. For more detailed fault codes, press and hold the ENTER key (whilst Err41 is showing) to display the turbo pump system status word. The lower 16 bits of the status word are displayed in hexadecimal. Press the START / STOP key to clear the error message. Refer to the instruction manual of the turbo pump for detailed fault finding.

## 9. Storage

Use the following procedure to store the pumping system.

1. Shut down the pumping system as described in [Stop the pump with the turbo screen](#).
2. Isolate the pumping system from the electrical supply and disconnect it from the vacuum system.
3. Drain the oil from the backing pump (only applicable to the E2M1.5 rotary vane pump) as described in the instruction manual. Refer to [General description](#) on page 8.
4. Place protective covers over the inlet and outlet flanges.
5. For the fastest pump down after the pumping system is reinstalled, seal the turbomolecular pump inside a plastic bag together with a suitable desiccant.
6. Store the pumping system in cool, dry conditions until required for use.

## 10. Disposal

Dispose of the pumping system and any components and accessories safely and in accordance with all local and national safety and environmental requirements.

Particular care must be taken with any components that have been contaminated with dangerous process substances.

For instruction on draining the oil from the E2M1.5 rotary vane pump refer to the instruction manual for the pump. Refer to [General description](#) on page 8.

## 11. Service

Our products, spares and accessories are available from our companies in Belgium, Brazil, China, France, Germany, Israel, Italy, Japan, Korea, Singapore, United Kingdom, U.S.A and a world-wide network of distributors. The majority of these centres employ Service Engineers who have undergone our comprehensive training courses.

Order spare parts and accessories from our nearest company or distributor. When ordering, state for each part required:

- Model and Item Number of the equipment
- Serial number
- Item Number and description of part.

Our products are supported by a world-wide network of our Service Centres. Each Service Centre offers a wide range of options including: equipment decontamination, service exchange, repair, rebuild and testing to factory specifications. Equipment which has been serviced, repaired or rebuilt is returned with a full warranty.

Local Service Centres can also provide our engineers to support on-site maintenance, service or repair of equipment. For more information about service options, contact the nearest Service Centre or our other company.

### Note:

*Our policy is to provide support for product after obsolescence through various options including maintenance, repair, enhancement and replacement. Support will be available for several years after product obsolescence and in compliance with any applicable legislation. We will always undertake appropriate actions to ensure support is maintained and, where support is no longer possible, will ensure this is communicated to all affected customers with a suitable notice period.*

### 11.1 Return the equipment or components for service

Before you send your equipment to us for service or for any other reason, you must complete a Declaration of Contamination Form. The form tells us if any substances found in the equipment are hazardous, which is important for the safety of our employees and all other people involved in the service of your equipment. The hazard information also lets us select the correct procedures to service your equipment.

If you are returning equipment note the following:

- If the equipment is configured to suit the application, make a record of the configuration before returning it. All replacement equipment will be supplied with default factory settings.
- Do not return equipment with accessories fitted. Remove all accessories and retain them for future use.
- The instruction in the returns procedure to drain all fluids does not apply to the lubricant in pump oil reservoirs.

Download the latest documents from [edwardsvacuum.com/HSForms/](http://edwardsvacuum.com/HSForms/), follow the procedure in HS1, fill in the electronic HS2 form, print it, sign it, and return the signed copy to us.



**NOTICE:**

**If we do not receive a completed form, your equipment cannot be serviced.**

## 12. Spares



### **CAUTION: REDUCED RELIABILITY**

**Use of spares, not supplied by us, may result in reduced reliability and performance and will invalidate product warranty.**

The spares available for the turbo pump and backing pumps are listed in the CD instruction manuals supplied with your equipment.

Refer to [General description](#) on page 8.

## 13. Accessories

### 13.1 TAV vent valve and vent port adaptor (for nEXT300 turbo pump)

Two solenoid-operated vent-valves are available for system venting. The valves are 24 V d.c., normally-open and can be driven by the Controller. The solenoid-valve is fitted in place of the manual-valve, or alternatively can be fitted with an adaptor (supplied with the valve) and can be used with any suitable NW10 flanged port on your vacuum system. TAV5 is suitable for smaller vacuum systems. TAV6 has a higher conductance and is suitable for larger vacuum systems (typically with volume greater than 10 litres).

*Table 21 TAV vent valve kits and adaptor*

Description	Item number
TAV5 vent-valve (orifice diameter 0.5 mm)	B58066010
TAV6 vent-valve (orifice diameter 1.0 mm)	B58066020
Vent port adaptor NW10 -1/8 inch BSP male	B58066011

### 13.2 Outlet mist filter(for E2M1.5 rotary vacuum pump)

The outlet mist filter separates and traps oil droplets in the pump outlet to prevent oil mist discharge.

For all other accessories such as gauges, active cables and mains leads, refer to the pumping system ordering information in our product catalogue.

*Table 22 Outlet mist filter*

Description	Item number
EMF3 outlet mist filter	A46220000



## EU Declaration of Conformity

This declaration of conformity is issued under the sole responsibility of the manufacturer:

**Edwards Ltd**

Innovation Drive  
Burgess Hill  
West Sussex  
RH15 9TW  
UK

**Documentation Officer**

Jana Sigmunda 300  
Lutín , 78349  
Czech Republic  
T: +42(0) 580 582 728  
[documentation@edwardsvacuum.com](mailto:documentation@edwardsvacuum.com)

The product specified and listed below:

- |  |            |
|--|------------|
| • T-Station 300D Dry ISO100 200-240V   | TS300D4001 |
| • T-Station 300D Dry ISO100 100-120V   | TS300D4002 |
| • T-Station 300D Dry CF100 200-240V    | TS300D5001 |
| • T-Station 300D Dry CF100 100-120V    | TS300D5002 |
| • T-Station 300D Wet ISO100 200-240V   | TS300W4001 |
| • T-Station 300D Wet ISO100 100-120V   | TS300W4002 |
| • T-Station 300D Wet CF100 200-240V    | TS300W5001 |
| • T-Station 300D Wet CF100 100-120V    | TS300W5002 |
| • T-Station 300 Dry ISO100 mXDS3s 230V | TS300M2003 |
| • T-Station 300 Dry ISO100 mXDS3s 115V | TS300M2006 |
| • T-Station 300 Dry ISO100 mXDS3s 200V | TS300M2004 |
| • T-Station 300 Dry ISO100 mXDS3s 100V | TS300M2007 |
| • T-Station 300 Dry CF100 mXDS3s 230V  | TS300M3003 |
| • T-Station 300 Dry CF100 mXDS3s 115V  | TS300M3006 |
| • T-Station 300 Dry CF100 mXDS3s 200V  | TS300M3004 |
| • T-Station 300 Dry CF100 mXDS3s 100V  | TS300M3007 |

Is in conformity with the relevant Union harmonisation legislation:

- |            |  |
|------------|--|
| 2006/42/EC | Machinery directive<br><i>Note: The safety objectives of the Low Voltage Directive 2014/35/EU were complied with in accordance with Annex 1 No. 1.5.1 of this directive.</i> |
| 2014/30/EU | Electromagnetic compatibility (EMC) directive<br>Class A Emissions, Industrial Immunity  |
| 2011/65/EU | Restriction of certain hazardous substances (RoHS) directive<br>as amended by Delegated Directive (EU) 2015/863  |

Based on the requirements of relevant harmonised standards and technical documentation:

- |                         |   |
|-------------------------|---|
| EN 1012-2:1996 +A1:2009 | Compressors and vacuum pumps. Safety requirements. Vacuum pumps   |
| EN 61326-1:2013         | Electrical equipment for measurement, control and laboratory use. EMC requirements.<br>General requirements |

This declaration, based on the requirements of the listed Directives and EN ISO/IEC 17050-1, covers all product serial numbers from this date on: 2023-10-18

You must retain the signed legal declaration for future reference  
This declaration becomes invalid if modifications are made to the product without prior agreement.

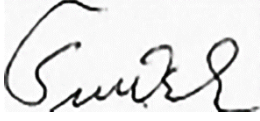

*Petr Šmerek – Engineering Manager  
Scientific Vacuum Division, Lutín*



*Jan Večeřa – General Manager  
Lutín, CZ*



## Declaration of Conformity

**Edwards Ltd**

Innovation Drive  
Burgess Hill  
West Sussex  
RH15 9TW  
UK

**Documentation Officer**

[documentation@edwardsvacuum.com](mailto:documentation@edwardsvacuum.com)

This declaration of conformity is issued under the sole responsibility of the manufacturer.

• T-Station 300D Dry ISO100 200-240V	TS300D4001
• T-Station 300D Dry ISO100 100-120V	TS300D4002
• T-Station 300D Dry CF100 200-240V	TS300D5001
• T-Station 300D Dry CF100 100-120V	TS300D5002
• T-Station 300D Wet ISO100 200-240V	TS300W4001
• T-Station 300D Wet ISO100 100-120V	TS300W4002
• T-Station 300D Wet CF100 200-240V	TS300W5001
• T-Station 300D Wet CF100 100-120V	TS300W5002
• T-Station 300 Dry ISO100 mXDS3s 230V	TS300M2003
• T-Station 300 Dry ISO100 mXDS3s 115V	TS300M2006
• T-Station 300 Dry ISO100 mXDS3s 200V	TS300M2004
• T-Station 300 Dry ISO100 mXDS3s 100V	TS300M2007
• T-Station 300 Dry CF100 mXDS3s 230V	TS300M3003
• T-Station 300 Dry CF100 mXDS3s 115V	TS300M3006
• T-Station 300 Dry CF100 mXDS3s 200V	TS300M3004
• T-Station 300 Dry CF100 mXDS3s 100V	TS300M3007

The object of the declaration described above is in conformity with relevant statutory requirements:

Supply of Machinery (Safety) Regulations 2008

*The objectives of the Electrical Equipment (Safety) Regulations 2016 are governed by Annex 1 1.5.1 of this regulation.*

Electromagnetic Compatibility Regulations 2016

Class A Emissions, Industrial Immunity

Restriction of the Use of Certain Hazardous Substances in Electrical and Electronic Equipment Regulations 2012

Relevant designated standards or technical specifications are as follows:

EN 1012-2:1996 +A1:2009 Compressors and vacuum pumps. Safety requirements. Vacuum pumps

EN 61326-1:2013 Electrical equipment for measurement, control and laboratory use. EMC requirements. General requirements

This declaration, based on the requirements of the listed Statutory Instruments and EN ISO/IEC 17050-1, covers all product serial numbers from this date on: *2023-10-18*

You must retain the signed legal declaration for future reference  
This declaration becomes invalid if modifications are made to the product without prior agreement.

**Signed for and on behalf of Edwards Ltd**

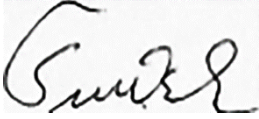

*Petr Šmerek – Engineering Manager  
Scientific Vacuum Division, Lutín*



*Jan Večeřa – General Manager  
Lutín, CZ*

## ADDITIONAL LEGISLATION AND COMPLIANCE INFORMATION

**EMC (EU, UK):** Industrial equipment

Caution: This equipment is not intended for use in residential environments and may not provide adequate protection to radio reception in such environments.

**RoHS (EU, UK):** Material Exemption Information

This product is compliant with the following Exemptions

Annex III:

- 6(b) **Lead** as an alloying element in aluminium containing up to 0.4% by weight
- 6(c) Copper alloy containing up to 4% **lead** by weight

**REACH (EU, UK)**

This product is a complex article which is not designed for intentional substance release. To the best of our knowledge the materials used comply with the requirements of REACH. The product manual provides information and instruction to ensure the safe storage, use, maintenance and disposal of the product including any substance based requirements.

Article 33.1 Declaration (EU, UK)

This product contains Candidate List Substances of Very High Concern above 0.1%ww by article as clarified under the 2015 European Court of Justice ruling in case C-106/14.

- Lead (Pb)  
This substance is present in certain aluminium and brass components.

### **Additional Applicable Requirements**

The product is in scope for and complies with the requirements of the following:

2012/19/EU	Directive on waste electrical and electronic equipment (WEEE)
EN 61010-1:2010 +A1:2019	Safety requirements for electrical equipment for measurement, control and laboratory use. General requirements

材料成分声明  
China Material Content Declaration

部件名称 Part name 	有害物质 Hazardous Substances					
	铅 Lead (Pb)	汞 Mercury (Hg)	镉 Cadmium (Cd)	六价铬 Hexavalent Chromium (Cr VI)	多溴联苯 Polybrominated biphenyls (PBB)	多溴二苯醚 Polybrominated diphenyl ethers (PBDE)
铸铝及铝合金制品 Aluminium alloys	X	O	O	O	O	O
铜管管件 Brass pipe fitting	X	O	O	O	O	O
铜接头 Brass connectors	X	O	O	O	O	O
<p>O: 表示该有害物质在该部件的所有均质材料中的含量低于 GB/T 26572 标准规定的限量要求。 O: Indicates that the hazardous substance contained in all of the homogeneous materials for this part is below the limit requirement in GB/T 26572.</p> <p>X: 表示该有害物质在该部件的至少一种均质材料中的含量超出 GB/T26572 标准规定的限量要求。 X: Indicates that the hazardous substance contained in at least one of the homogeneous materials used for this part is above the limit requirement of GB/T26572.</p>						



