



Boekel Scientific Platelet Agitator
Model 301300, 301300-2
Operating Instructions

Contents

1. INDICATIONS FOR USE	3
1.1. CONTRAINDICATIONS	3
2. SAFETY	3
2.1. EMF INTERFERENCE	4
3. PRODUCT INFORMATION.....	5
3.1. INTRODUCTION	5
4. ASSEMBLY.....	5
4.1. UNPACKING	5
4.2. INSTALLATION.....	6
5. SYSTEM OVERVIEW.....	7
5.1. MAJOR COMPONENTS.....	7
5.2. SHELF DETAILS.....	8
6. OPERATION.....	9
6.1. STANDALONE PLATELET AGITATOR.....	9
6.2. PLATELET AGITATOR INSTALLED IN A PLATELET INCUBATOR.....	10
6.3. ALARMS	11
6.3.1. AGITATION ALARM.....	11
7. SPECIFICATIONS & OPERATING CONDITIONS.....	12
8. RECOMMENDED MAINTENANCE	13
8.1. CLEANING	13
8.1.1. CLEANING SPILLED PLATELETS	13
8.2. REPLACEMENT OF FUSES.....	14
9. ACCESSORIES	14
10. TROUBLESHOOTING.....	16
11. WARRANTY AND SERVICE	17
11.1. WARRANTY	17
11.2. SERVICE.....	17

1. Indications for Use

The Boekel Scientific Platelet Agitator is intended for use in blood banks, hospitals, and laboratories where it is required to store Pooled Platelets and Apheresis Platelets. This unit is designed in accordance with AABB guidelines and is FDA listed. The platelet agitator combined with a platelet incubator provides the recommended controlled temperature and agitation to maintain product quality.

1.1. Contraindications

This device is not intended for the storage of, but not limited to, Red Blood Cells, Whole Blood, Hematopoietic Progenitor Cells, Umbilical Cord Blood, Fresh Frozen Plasma, Cryoprecipitate AHF or Plasma Frozen within 24 hours after Phlebotomy.

2. Safety

The following symbols marked on the equipment mean:



Caution: Please read and understand all necessary installation and operating instructions prior to operating the system.

Always observe the following safety precautions:



- Use only as specified by the operating instructions or the intrinsic protection may be impaired.



- **WARNING:** Do not modify the system or its components. Any alterations or modifications to the Platelet Agitator may be dangerous and will void the warranty.



- **WARNING:** To avoid the risk of electric shock, this equipment must only be connected to a supply mains with protective earth.

- Connect only to a power supply with a voltage corresponding to that on the serial number label.



- Connect only to a power supply that provides a safety ground terminal.

- After transport or storage in humid conditions, dry out the unit before connecting it to the supply voltage. During drying out, the intrinsic protection may be impaired.



- Disconnect power before servicing, moving, or cleaning.

- Remove all bags of platelets before attempting to move, service, or clean the system.

- Do not position system where it is difficult to reach the inlet or power switch.

- Do not block or restrict ventilation slots. Allow at least 3" clearance around the entire unit (unless installed in a Boekel Platelet Incubator).

- It is the user's responsibility to carry out appropriate decontamination per their

SOP if platelets or other hazardous material is spilled on or inside the equipment. Refer to Section 8.1.1 for a general guideline on how to proceed with decontamination.



- Before using any cleaning or decontamination method, users should verify that the method of cleaning will not damage the unit.
- If liquid is spilled inside the unit, disconnect it from the power supply and have it checked by a competent person.
- Do not use with flammable, corrosive or hazardous material.
- **RISK OF TRAPPING:** System has moving parts! Do not attempt to add or remove bags from the shelves until the agitation function has completely stopped.
- Electromagnetic interference could affect the operation of the system if it is used in the vicinity of devices that have not been evaluated to the relevant EMC standard/s.

2.1. EMF Interference

This system may cause interference to radio and television reception or to equipment sensitive to electromagnetic fields. When installed properly, the system has been designed to minimize this effect. However, there is no guarantee that electromagnetic interference will not be caused by the system.

If the system does cause interference to radio, television, or other equipment, which can be determined by turning the instrument off and on, the user may attempt to correct the interference by one or more of the following measures:

- Increase the distance between the system and the radio/TV receiver.
- Connect the system to an outlet on an electrical circuit different from that which the radio/TV receiver is connected.

If this system is used near an intense electromagnetic source, interference noise may cause an adverse effect on the system performance or functionality.

The system is designed to minimize possible interference from external electromagnetic fields; however, there is no guarantee that external electromagnetic fields will not have an effect on this instrument.

If the system does incur electromagnetic interference, which can be determined by turning on and off possible source(s) of electromagnetic interference nearby, the user may attempt to correct the interference by one or more of the following measures:

- Reorient the instrument.
- Increase separation between the instrument and possible source(s) of electromagnetic interference.
- Connect the instrument to an outlet on a different electrical circuit from the possible source(s) of electromagnetic interference.
- Check that any other device connected to the system is not affected by electromagnetic interference.

3. Product Information

3.1. Introduction

The Boekel Scientific Platelet Agitator offers controlled and gentle agitation of platelet bags. When used with a Boekel Scientific Platelet Incubator to regulate temperature, the Agitator offers a complete solution for maintaining platelet product quality. Alarms protect the integrity of the product and the unit, and a communication connection provides integration with the Incubator control system.

4. Assembly

4.1. Unpacking

- Remove packing materials carefully, and retain for future shipment or storage of the unit.
- Inspect for damage. Report all shipping damage to the carrier immediately. Shipping damage is covered by the carrier and repair/replacement for shipping damages must be coordinated through the carrier.
- Complete and return the Warranty Registration Card, enter your information online at <http://boekelsci.com/support/registration.cfm> or scan the QR code and submit the information online.
- Package should contain:
 - (1) Boekel Scientific Platelet Agitator which contains (8) shelves
 - (1) Power line cord
 - (1) Operating instructions

4.2. Installation

1. Place the Platelet Agitator on a flat and stable surface, making certain the sides and back have at least 3 inches of clearance (unless installed in a Boekel Scientific Platelet Incubator).
2. Fit the power line cord into the IEC power socket on the right side of the unit and plug the power cord into a properly grounded outlet.
3. Power on the unit using the On/Off switch on the front panel of the base of the system. The agitator will turn on.
4. Once the system is verified to be working, the system may be turned off for future use, for loading with platelet bags, or for disassembly to be installed inside the incubator.
5. To install the unit inside a Boekel Scientific Platelet Incubator, please refer to the Platelet Incubator Operating Instructions.

5. System Overview

5.1. Major Components

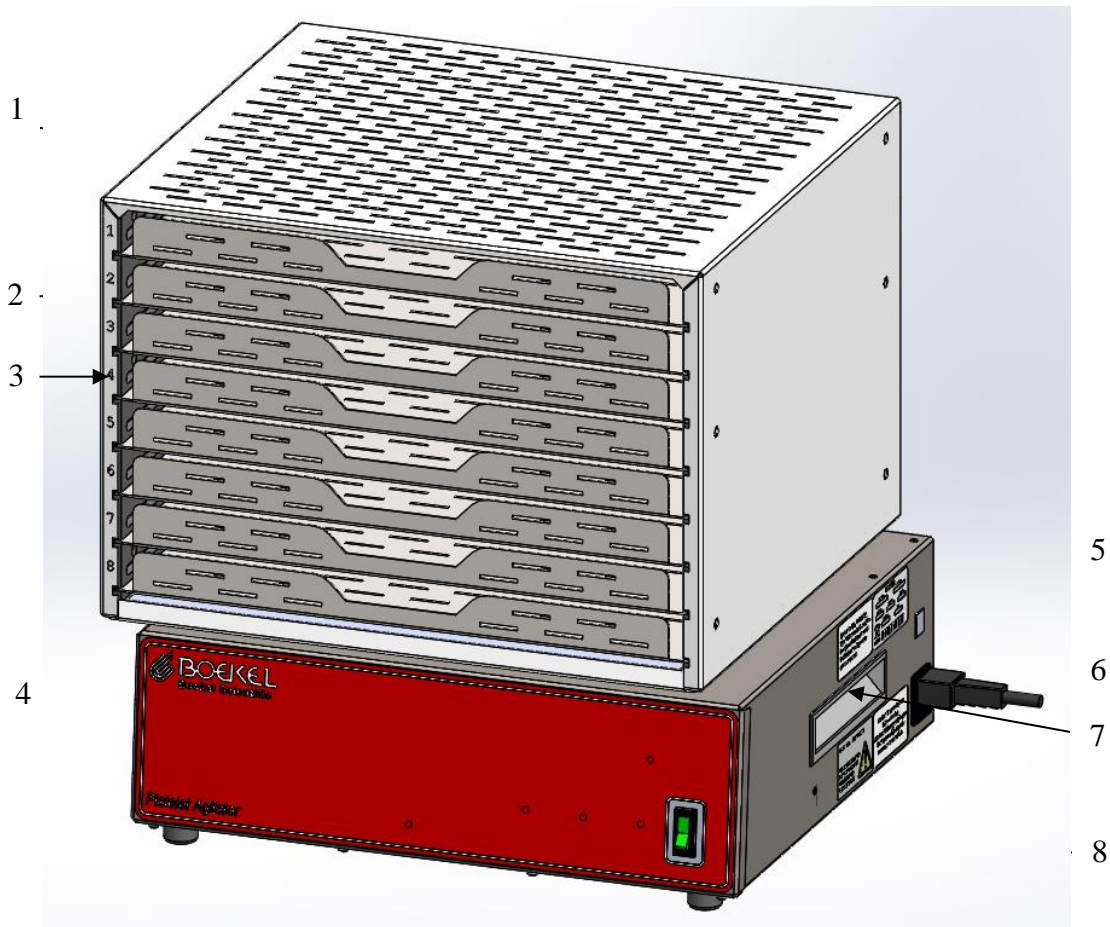

1. Upper Housing – Part of the system that holds the shelves and platelet bags. Moves in an orbital motion.
2. Shelf – Holds platelet bags during agitation. Removable for cleaning via (2) quick-release pins.
3. Shelf Numbers – Permanently stamped numbers allow quick reference to the shelf location.
4. Lower Housing – Stationary system base that contains control components.
5. Communications Connection – RJ11 port to connect to a platelet incubator for basic communication and alarming the unit.
6. Power Connection/Fuse housing – Used for connecting power to the unit and electrical protection.
7. Lift Handle – One on each side to assist in lifting and moving the agitator
8. Agitator Power Switch – Turns the agitator on/off.

5.2. Shelf Details

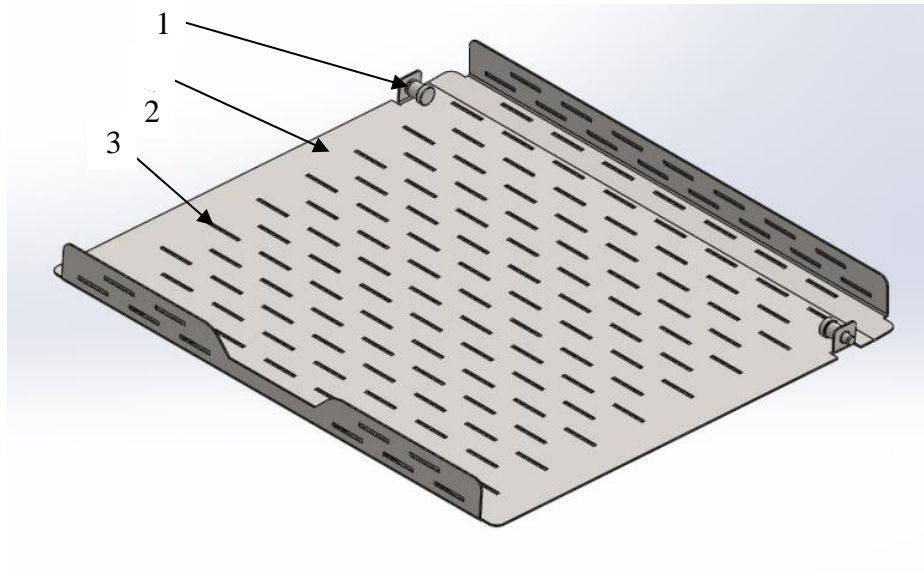

1. Quick-Release Pins – When extended, act as stops to prevent the shelves from being accidentally removed. When retracted, allow quick removal of the shelves for cleaning.
2. Antimicrobial Powder Coating – Corrosion resistant coating that allows the shelves to be cleaned easily.
3. Vent – Perforations in the shelf enhance airflow to help keep platelet bags at a uniform temperature.

6. Operation

6.1. Standalone Platelet Agitator

This sequence of operation will be dictated by the end user's standard operating procedure. However, the general sequence of operation for the standalone Platelet Agitator is as follows:

Load Bags of Platelets

1. Ensure the agitator has been turned off.
2. Slide out an empty shelf until it reaches the stops.
3. Load one or more bag(s) of platelets on the shelf.
4. Slide the shelf completely back into the enclosure.
5. Continue loading bags in this manner until finished, or all the shelves are full.
6. *NOTE:* Loading of the bags should be done as quickly as possible, while maintaining careful handling of the bags, in order to minimize the amount of time that the platelets are not being agitated.
7. Toggle the agitator power switch up to the "On" position. The switch lights up and the agitator top enclosure begins to move in an orbital path.
8. The agitator will cycle at approximately 60 RPM (non-adjustable) and is designed to run continuously 24/7.

Unload Bags of Platelets

1. Toggle the agitator power switch down to the "Off" position. The switch light turns off and the agitator top enclosure stops moving.
2. Ensure the top enclosure has stopped moving before attempting to remove bags of platelets.
3. Slide out the shelf with the desired bag(s) of platelets until the shelf reaches the stops.
4. Remove the bag of platelets.
5. Slide the shelf completely back into the enclosure.
6. Remove additional bags in this manner, if desired.
7. Once all shelves have been pushed back into the enclosure, if there are bags remaining in the agitator, toggle the agitator power switch up to the "On" position to resume agitation.
8. *NOTE:* Unloading of the bags should be done as quickly as possible, while maintaining careful handling of the bags, in order to minimize the amount of time that the platelets are not being agitated.

6.2. Platelet Agitator Installed in a Platelet Incubator

This sequence of operation will be dictated by the end user's standard operating procedure. However, the general sequence of operation for the agitator as installed in a corresponding incubator is as follows:

Load Bags of Platelets

1. Open the front door of the incubator. If the agitator has been running, it will stop when the door is opened.
2. Ensure the top enclosure has stopped moving before attempting to load bags of platelets.
3. Slide out an empty shelf until it reaches the stops.
4. Load one or more bags of platelets on the shelf.
5. Slide the shelf completely back into the enclosure.
6. Continue loading bags in this manner until finished, or all the shelves are full.
7. *NOTE:* Loading of the bags should be done as quickly as possible, while maintaining careful handling of the bags, in order to minimize the amount of time that the platelets are not being agitated as well as minimizing the amount of time the incubator door is open.
8. Ensure the agitator power switch is toggled up to the "On" position. The switch *will not* light up and the agitator *will not* resume operation while the incubator door is open.
9. Close the front door of the incubator. The agitator power switch will light up, and the agitator will start operation.
10. The agitator will cycle at approximately 60 RPM (non-adjustable) and is designed to run continuously 24/7.
11. Using the incubator touchscreen, log the new bags into the incubator per the incubator operating instructions.

Unload Bags of Platelets

1. Open the front door of the incubator. The agitator switch light turns off and the agitator top enclosure stops moving.
2. Ensure the top enclosure has stopped moving before attempting to unload bags of platelets.
3. Slide out the shelf with the desired bag(s) of platelets until the shelf reaches the stops.
4. Remove the bag of platelets.
5. Slide the shelf completely back into the enclosure.
6. Remove additional bags in this manner, if desired.
7. Once all shelves have been pushed back into the enclosure, close the front door of the incubator.
8. Once the door is closed, the agitator power switch will light up, and the agitator will resume operation.
9. *NOTE:* Unloading of the bags should be done as quickly as possible, while maintaining careful handling of the bags, in order to minimize the amount of time that the platelets are not being agitated as well as minimizing the amount of time the incubator door is open.

10. Using the incubator touchscreen, log the removal of the bags from the incubator per the incubator operating instructions.

6.3. Alarms

The Platelet Agitator, on its own, has an alarm to protect the product quality and the system itself. When an alarm condition occurs, the motor will turn off and a buzzer/beeper will sound. The alarm is silenced only by turning off the system.

When the Platelet Agitator is installed in a Boekel Scientific Platelet Incubator and connected via the communications cable, the Incubator control system will signal any alarm conditions. For more information on the Incubator alarms, please refer to the Platelet Incubator Operating Instructions.

6.3.1. Agitation Alarm

The platelet agitator is equipped with a detection system to detect unintended stoppage or erratic system behavior.

The agitation alarm will be triggered for the following conditions:

- Upper housing jam resulting in motion stoppage
- Upper housing became decoupled from the motor resulting in motion stoppage
- The speed of rotation decreases substantially below 60 RPM
- Motor failure
- Rotation sensor failure
- Control system failure

For corrective action for this alarm, please refer to Section 10 Troubleshooting. If the condition is not corrected, the alarm will be triggered each time the agitator is turned on.

7. Specifications & Operating Conditions

Platelet Agitator:	Model # 301300	Model # 301300-2
Electrical:	115V, 60 Hz, 0.9 A Peak, 0.4 A Steady State, 50 Watts	230V, 50 Hz, 0.5A Peak, 0.25 Steady State, 50 watts
Capacity:	(48) Random Bags or (8-16) Apheresis Bags Total bag weight not to exceed 25 lb.	
Speed:	60 RPM nominal; speed is not adjustable	
Orbit:	2" diameter	
Duty:	Continuous, 24/7 operation	
Alarms:	Agitation Failure Alarm	
Operation Temperature Range:	10°C – 30°C Ambient	
Humidity:	25-90% (non-condensing)	
Connectivity:	RJ11	
Product Dimensions:	18.5" W x 16.5" D x 17.5" H	
Shelf Dimensions:	13.75" W x 14.25" D x 1.25" H Clearance	
Shipping Weight:	60 lb.	
Transport and Storage Temperature Range:	10°C – 50°C	
Altitude:	0 - 2,000 m above sea level	

8. Recommended Maintenance

All Boekel laboratory products are designed to comply with IEC61010-1. No routine maintenance is required.

8.1. Cleaning

Before using any cleaning or decontamination method, users should verify that the method of cleaning will not damage the unit.

1. Turn power switch to the off (O) position.
2. Remove mains power supply cord.
3. If so configured, remove from incubator and remove all shelves.
4. Inspect for damage and corrosion and repair if necessary.
5. If the agitator is soiled it will first need to be cleaned with an alkaline liquid detergent.

The following detergent trade names are alkaline liquid detergents. Prepare the cleaning solution in accordance with the manufacturer's instructions:

- a) Micro-90®
- b) Stan-Bio Bioclean®
- c) Contrad®

The following cleaners are not recommended and could damage the equipment:

- a) Hypochlorite Solutions
- b) Corrosive Detergents
- c) Acidic Solutions
- d) Salt Solutions

6. Clean: Use a lint free cloth to clean the exterior surfaces of the agitator and all shelves. Remove all visible dirt from surfaces.
7. Remove Cleaner: Use a lint free cloth and sterile deionized water to wipe shelves or equipment associated with the agitator. Perform this action twice to remove all cleaner. Do not submerge any equipment or shelves with deionized water.
8. Disinfect: Use a lint free cloth and a 70% isopropyl alcohol solution to clean the exterior surfaces of the agitator and all shelves.
9. Return removeable equipment and / or shelves to the agitator, and the agitator to the incubator, if so configured.

8.1.1. Cleaning Spilled Platelets

In the event that a bag leaks or tears and platelets are spilled in or on the

unit, special considerations must be made to decontaminate the unit.

1. As soon as evidence of a leak is discovered, immediately power down the unit using the switch on the front panel of the base.
2. Remove mains power supply cord.
3. Remove the communications cable.
4. Per your SOP, remove the leaking/spilled bag of platelets and dispose of it properly.
5. Per your SOP, remove all remaining bags of platelets from the system and either temporarily store them in an alternate suitable location or dispose of the bag(s) properly.
6. Remove the Platelet Agitator from the Platelet Incubator (if applicable).
7. Remove each shelf from the upper housing and clean and decontaminate each shelf thoroughly per your SOP.
8. Remove the interior cover from the upper housing by removing the (4) screws from it.
9. Per your SOP, clean and decontaminate the interior cover and the upper housing.
10. Inspect the system for evidence that platelets have leaked into the lower housing. If platelets have leaked into the lower housing, contact Boekel Scientific for additional instructions.
11. Per your SOP, clean and decontaminate the lower housing.
12. Once the entire unit has been verified to be decontaminated and the unit is completely dry, reassemble the unit by installing the components in reverse order.

8.2. Replacement of Fuses

There are two supply fuses located in the fuse drawer of the power entry module. To change the fuses:

1. Turn power switch to the off (O) position.
2. Disconnect the unit from the power supply.
3. Remove the line cord from the power entry module on the right side of the unit.
4. Pull back on the fuse drawer catch (located on the bottom of the power entry module).
5. Pull out the fuse drawer.
6. Check and replace with the correct fuses if necessary. The fuses must be 5mm x 20mm, time delay, rated at 0.63A 250V.
7. Push the drawer back in and reconnect the unit to the power supply.

9. Accessories

Item #	Description
C1906220	Replacement Shelf
902-1076	Communications Cord
606-0032	Hospital Grade Power Cord

10. Troubleshooting

Symptoms	Possible Cause	Corrective Action
Power		
The unit does not power on.	<ul style="list-style-type: none"> Power cord not connected to Electrical receptacle on Unit, and/or Wall outlet 	<ul style="list-style-type: none"> Fit the power line cord into the IEC power socket on the right side of the unit and verify if plugged into a properly grounded outlet
	<ul style="list-style-type: none"> Power supply failure 	<ul style="list-style-type: none"> Verify that power source is active and regulated
	<ul style="list-style-type: none"> Room Circuit Breaker has been tripped 	<ul style="list-style-type: none"> Reset circuit breaker
	<ul style="list-style-type: none"> Fuses are blown 	<ul style="list-style-type: none"> Follow instructions in section 8.2 for replacing fuses.
	<ul style="list-style-type: none"> Malfunctioning Power Switch 	<ul style="list-style-type: none"> Contact Boekel Scientific for Service
	<ul style="list-style-type: none"> Malfunctioning Control System 	<ul style="list-style-type: none"> Contact Boekel Scientific for Service
Alarms		
Agitation Alarm (system does not operate prior to the alarm)	<ul style="list-style-type: none"> Upper Housing is jammed and cannot move 	<ul style="list-style-type: none"> Turn off power and remove any obstructions between the upper and lower housing
	<ul style="list-style-type: none"> Upper Housing is overloaded above the 25 lb. weight limit 	<ul style="list-style-type: none"> Turn off power and remove platelet bags until the load is less than 25 lb
	<ul style="list-style-type: none"> Upper Housing has become uncoupled from the motor 	<ul style="list-style-type: none"> Contact Boekel Scientific for Service
	<ul style="list-style-type: none"> Malfunctioning Motor 	<ul style="list-style-type: none"> Contact Boekel Scientific for Service
	<ul style="list-style-type: none"> Malfunctioning Rotation Sensor 	<ul style="list-style-type: none"> Contact Boekel Scientific for Service
	<ul style="list-style-type: none"> Malfunctioning Control System 	<ul style="list-style-type: none"> Contact Boekel Scientific for Service
Agitation Alarm (system operates prior to the alarm)	<ul style="list-style-type: none"> Upper Housing has become partially uncoupled from the motor 	<ul style="list-style-type: none"> Contact Boekel Scientific for Service
	<ul style="list-style-type: none"> System has slowed down to an unacceptable speed due to excessive loading or motor failure 	<ul style="list-style-type: none"> Turn off power and remove platelet bags until the load is less than 25 lb Contact Boekel Scientific for Service
	<ul style="list-style-type: none"> Malfunctioning Rotation Sensor 	<ul style="list-style-type: none"> Contact Boekel Scientific for Service

11. Warranty and Service

11.1. Warranty

When used in the appropriate laboratory conditions and in accordance with these operating instructions, Boekel Scientific warrants this product to be free of defective parts, material and workmanship for a period of two years from the date of shipment. The liability of Boekel Scientific for any defective equipment during the warranty period shall be limited to the repair of defective equipment or replacement thereof without charge for parts or labor.

11.2. Service

If service is required, contact Boekel Customer Service at 1-800-336-6929. A Decontamination Certificate must be completed, signed by the user, and returned to Boekel Scientific prior to receiving the RMA number.



Boekel Scientific
855 Pennsylvania Blvd.
Feasterville, PA 19053 USA
Phone: (215) 396-8200 or (800) 336-6929
Fax: (215) 396-8264
Email: Boekel-info@boekelsci.com