

# ARCTIKO Flexaline PRE 60-US

true cooling specialists



## BIOMEDICAL REFRIGERATOR

The PRE 60-US is the pinnacle of our Flexaline range, a sophisticated glass door biomedical refrigerator meticulously built to meet the requirements of biomedical applications. These refrigerators, which are fitted with precise temperature controls and cutting-edge technology, serve an important role in preserving the integrity of medicinal supplies and developing scientific achievements.

### ► ENERGY STAR CERTIFIED

Energy Star certified, guaranteeing exceptional energy efficiency and reduced environmental impact, while maintaining superior performance in temperature-sensitive storage applications.

### ► INTEGRATED DATA LOGGER

Integrated data logger, providing accurate monitoring of temperature conditions. This allows for precise data recording and analysis, ensuring optimal storage conditions for critical samples and maintaining regulatory compliance.

### ► FORCED AIR COOLING

Forced air cooling provides excellent temperature stability. Forcing the airflow around the stored items ensures quick temperature recovery after door openings.

### ► KEY LOCK SECURITY

Equipped with a secure key lock, providing an added layer of protection for valuable contents and preventing unauthorized access. This feature ensures the integrity and confidentiality of stored items, making it ideal for environments where security is paramount.

### ► SNAP/EPA COMPLIANT REFRIGERANT

Utilizes refrigerants that are fully compliant with the Environmental Protection Agency (EPA) and the Significant New Alternatives Policy (SNAP) regulations, ensuring environmentally responsible operation without compromising performance or safety.



PRE 60-US



Microprocessor controller with visual and acoustic alarms, high/low temperature alarm, open door alarm, and integrated data logger.



Adjustable shelves for flexible storage.



All models feature durable and cost-saving, customizable LED lighting for improved sample visibility.



DATA LOGGER



USB PORT



FORCED AIR COOLING



ADJUSTABLE SHELVES



VARIOUS SAFETY FEATURES

\* The pictures shown are for reference only, actual product size may vary. Please read the dimensions of the product in the specifications.

The ARCTIKO Flexaline series includes the following features, and more:

- Energy star certified
- SNAP/EPA compliant refrigerant
- Built-in data logger
- Key lock
- Microprocessor controller
- Adjustable shelves
- Automatic defrost
- Access port for external sensor
- Anti freeze thermostat

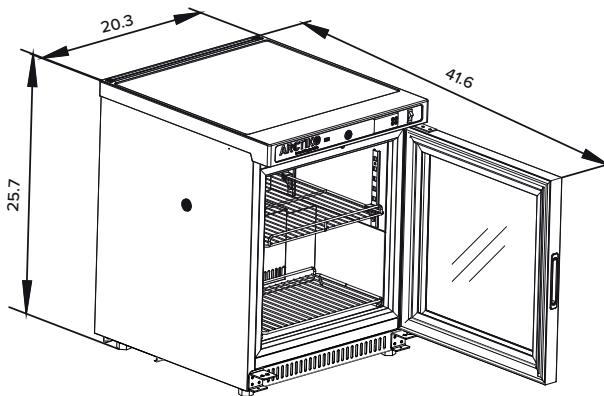
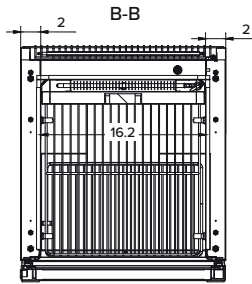
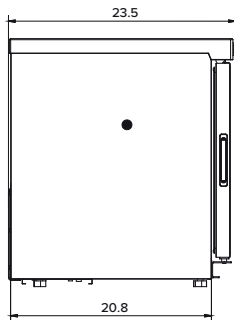
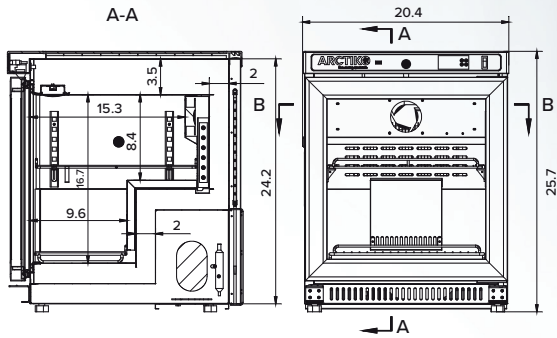

MODEL	PRE 60-US	
Main specifications	Item code	1900019-01
	Temperature range (°C)	+2 / +8 °C
	Max Ambient temperature (°C)	+32 °C
	Capacity (L)	60
	Capacity (cu.FT)	2.12
	Exterior dimensions WxDxH (inches)	21 x 24 x 26
	Interior dimensions WxDxH (inches)	16 x 17 x 17
	Weight (lb)	73
	Insulation (Inches)	1.97
	Cooling technology	Forced Air
Controller model / probe type	Honker / NTC	
Power	Power supply (V)	110
	Plug Type	5-15P
	Cord Length	2.0 m
	Frequency (Hz)	60
	Power consumption (kWh/24h)	1.3
	AMP (A)	2.0
	Power (Watt)	108
Horsepower (HP)	1/7	
Alarm functions	Visual / acoustic alarm	Yes / Yes
	Power failure alarm	Yes
	Adjustable high / low-temperature alarm	Yes / Yes
	Open door alarm	Yes
	Probe failure alarm	Yes
	Low battery alarm	Yes
Data logging & external connection	Voltage-free contact for remote alarm (e.g. GSM alarm module)	Yes
	Electronic data logger	Yes
	USB port for software update & data download	Yes
Display features	Display type	Digital
Other features	Automatic defrost	Yes
	Antifreeze function	Yes
	Access port for external probe etc. (int. diameter "In")	0.79
	Light	Yes
	Lock with key	Yes
	Fixed feet (pcs) / levelling feet (pcs)	4 / 4
	Reversible door(s)	Yes
	Fixed shelves (pcs) / adjustable shelves (pcs)	0 / 2
	Max. no. of shelves / recommended max. no. of shelves (pcs)	2 / 2
Max load per shelf (lb)	33	
Refrigeration & cabinet	Number of compressors	1
	Refrigerant	R600a
	Interior cabinet material	Pre-coated aluminum sheet
	Exterior cabinet material	Galvanized steel powder coating
	Color (exterior cabinet)	White
Shipping	Foam type	Cyclopentane
	Shipping weight (lb)	92.6
	Shipping dimensions WxDxH (inches)	22 x 26 x 31
	Shipping volume (cu.FT)	10.59

