

Legal for Trade Class I and II Analytical and Precision Balances

Advanced Sensor Technology

Smart-SHS the latest advancement in our super hybrid design, construction and algorithms.

- Increased productivity via faster stabilization times (1 second in fast mode).
- Lower cost of ownership due to reduced number of parts and maintenance accessibility.

Legal for Trade Approved

The A&D Apollo GF-AN is NTEP certified & Measurement Canada approved, making it compliant in the United States and Canada.

The A&D Apollo GX-AN offers both Class I and Class II NTEP approvals for use in the United States.

- Versatile with NTEP selectable modes of e=d or e=10d (default mode) which displays a bracketed value as the additional digit for more accurate measurements and rounding. Includes a tamper proof physical sealing bracket and an e=d front label in the box.
- The GF-AN & GX-AN are equipped with basic weighing, Gross/Net/Tare display, parts counting (labeled not legal for trade) and percent weighing applications (MC only).
- GF-AN & GX-AN can also be connected to point-of-sale systems or printers via their standard RS-232 or USB ports. Ethernet or wireless interface options are also available.
- NTEP-P pharmacy setting available for pharmacy applications.

Practical Features

Leveling Made Easy

- Plug in, turn on, screen blinks for 5 seconds to prompt user to level.
- Bright-bubble – Large, easy-to-see, front mounted spirit level with LED illumination.
- Fly-thumbwheel is effortless & accessible allowing ergonomic adjustment with anti-slip feet.

Simple User Interface

- Six straightforward keys – ON/OFF/ZERO, CAL, MODE, SAMPLE, PRINT, TARE.
- Large Reverse Backlit LCD with black & white contrast provides excellent visibility.

Cleanable Robust Construction

- Stainless Steel Pan & Dust-plate can be easily removed for cleaning.
- Easy to assemble anti-static breeze break on 0.001 readability models.
- Die-cast Aluminum housing with anti-static ABS plastic cover provides extra stability and durability.

Flexible Interface & Security

- Standard RS-232C and USB – Toggle between the Quick USB mode or Virtual COM mode (bi-directional). A USB cable comes standard.
- Security Slot – Anti-theft lock (such as Kensington) to prevent loss.
- Internal Calibration on GX-AN models – Easy one touch button performs & documents internal calibration.



NTEP Approved Class II
GF-AN: CC# 20-039A1
Class I & II
GX-AN: CC# 21-045A1

MC Approved
Class II
AM-6158

KEY FEATURES:



Super Hybrid Sensor



GF-A External Calibration



GX-AN Internal Calibration



USB - Bidirectional Standard



RS-232C Standard



Ethernet Interface Option



Wireless BT Option

Specifications

GF-AN Models Legal-for-Trade	GF-123AN	GF-203AN	GF-303AN	GF-403AN	GF-603AN	GF-1202AN	GF-2002AN	GF-3002AN	GF-4002AN	GF-6002AN	GF-6001AN*	GF-10001AN	
GX-AN Models Legal-for-Trade	N/A	GX-203AN	GX-303AN	GX-403AN	GX-603AN	N/A	GX-2002AN	GX-3002AN	GX-4002AN	GX-6002AN	N/A	GX-10001AN	
Capacity	120 g	220 g	320 g	420 g	620 g	1220 g	2200 g	3200 g	4200 g	6200 g	6200 g	10200 g	
Readability	0.001 g					0.01 g					0.1 g		
Repeatability (A&D Standard mode)	0.001 g					0.01 g					0.1 g		
Scale division d (e=10d default)	0.00[1] g					0.0[1] g					0.[1] g		
Verified Scale division e (e=d)	0.01 g					0.1 g					1.0 g		
Linearity	±0.002 g					±0.02 g					±0.03 g	±0.1 g	
LFT Approved Class Accuracy	II												
Stabilization Time	~ 1 sec (~0.8 sec for 5 g)					~ 1 sec (~0.8 sec for 50 g)					~1 sec (~0.8 sec for 500 g)		
Sensitivity drift	±2 ppm / °C (10 °C to 30 °C / 50 °F to 86 °F, when automatic self-calibration is OFF)												
Calibration	GF-AN	External											
	GX-AN	Internal											
	Wt. g.	50 g 100 g	50 g 100 g 200g	50 g 100 g 200 g 300 g	50 g 100 g (100 g interval) 400 g	50 g 100 g (100 g interval) 600 g	500 g 1000 g	500 g 1000 g 2000g	500 g 1000 g 2000 g 3000 g	500 g 1000 g (1000 g interval) 4000 g	500 g 1000 g (1000 g interval) 6000 g	500 g 1000 g (1000 g interval) 6000 g	500 g 1000 g (1000 g interval) 10000 g
Display	Reverse Backlit LCD (Character height: 17.8 mm)												
Display Refresh Rate	5 times / second, 10 times / second or 20 times / second												
Operating environment	10 to 30 °C 50 to 86 °F, 85% R.H. or less (no condensation)												
Power supply / consumption	AC adapter / approx. 30 VA												
Communication Interface	Standard: RS-232C and USB Optional: Quick USB, LAN Ethernet (FXi-08), USB Host (GXA-24), Bluetooth Converters: AD-8529PC-W, AD8529PR-W												
Weighing pan size	128 mm × 128 mm / 5 × 5 in												
Dimensions (W × D × H)	212 (W) × 317 (D) × 93 (H) mm / 8.3 (W) × 12.5 (D) × 3.7 (H) in												
Net weight	5 kg / 11 lb												
Weighing Applications ⁱⁱ	NTEP Mode	Gross/Net/Tare, Below-Scale Weighing											
	NTEP P Pharmacy	Gross/Net/Tare, Counting (PCS)											
	MC Mode (GF-AN only)	Gross/Net/Tare, Counting (PCS), %/Percent											
Units of Measure:	NTEP-N g/Gram, OZ/Ounce, OZT/Troy Ounce, ct/Metric Carat, GN not available in 0.1g models, NTEP-P g/Gram, OZ/Ounce, lb/Pound, OZT/Troy Ounce, ct/Metric Carat, MC g/Gram, OZ/Ounce												
Options	Interfaces: GXA-03 2nd RS232, GXA-04 Comparator Relay, GXA-06 Analog output External Key Input Interfaces: GXA-23-PRINT, GXA-23-REZERO, GXA-23-PLUG Breeze Break: GXA-10 Large BB, GXA-17 Large BB with Ionizer GXA-25 External Ionizer, GXA-26 External IR Switch, GXA-27 Bluetooth, GXA-12 Animal Weigh Pan												
Accessories	TB247 Power Supply, AD-8127 Compact Printer, AD-1682 External Rechargeable Battery (for more accessories visit andweighing.com)												

i Under stable environment (no rapid temperature/humidity change, vibration, draft, magnetism, static, etc). The mass of the internal weight may vary with age.

ii One additional unit from tael (Singapore/HK jewelry/Taiwan/China), tola or Newton can be added upon request.

iii AN LFT models not all applications apply (excludes: statistical calculation, programmable unit, or minimum sample weight).

*GF-6001AN only NTEP certified

Specifications

GX-AN Models Legal-for-Trade		GX-124AN	GX-124AEN	GX-224AN	GX-224AEN	GX-324AN	GX-324AEN
Capacity		120 g		220 g		320 g	
Readability		0.0001 g		0.0001 g		0.0001 g	
Repeatability (A&D Standard mode)		0.0001 g		0.0001 g		0.0001 g	
Scale division d (e=10d default)		0.000[1] g		0.000[1] g		0.000[1] g	
Verified Scale division e (e=d)		0.001 g		0.001 g		0.001 g	
Linearity		±0.0002 g		±0.0002 g		±0.0002 g	
LFT Approved Class Accuracy		I					
Stabilization Time		~ 1.5 sec (100 g)		~ 2 sec (200 g) ~ 1.5 sec (100 g)		~ 2 sec (300 g) ~ 1.5 sec (100 g)	
Sensitivity drift		±2 ppm / °C (10 °C to 30 °C / 50 °F to 86 °F, when automatic self-calibration is OFF)					
Calibration	GX-AN	Internal					
Display		Reverse Backlit LCD (Character height: 17.8 mm)					
Display Refresh Rate		5 times / second, 10 times / second or 20 times / second					
Operating environment		10 to 30 °C 50 to 86 °F, 85% R.H. or less (no condensation)					
Power supply / consumption		AC adapter / approx. 30 VA					
Communication Interface		Standard: RS-232C and USB Optional: Quick USB, LAN Ethernet (FXI-08), USB Host (GXA-24), Bluetooth Converters: AD-8529PC-W, AD8529PR-W					
Weighing pan size		128 mm × 128 mm / 5 × 5 in					
Dimensions (W × D × H)		259 (W) × 358 (D) × 332 (H) mm / 10.2 (W) × 14.1 (D) × 13 (H) in					
Net weight		7 kg / 15.4 lb					
Weighing Applications ⁱⁱ	NTEP Mode	Gross/Net/Tare, Below-Scale Weighing					
	NTEP P Pharmacy	Gross/Net/Tare, Counting (PCS)					
	MC Mode (GF-AN only)	Gross/Net/Tare, Counting (PCS), %/Percent					
Units of Measure:		NTEP-N g/Gram, OZ/Ounce, OZT/Troy Ounce, ct/Metric Carat, GN not available in 0.1g models, NTEP-P g/Gram, OZ/Ounce, lb/Pound, OZT/Troy Ounce, ct/Metric Carat					
Options		Interfaces: GXA-03 2nd RS232, GXA-04 Comparator Relay, GXA-06 Analog output External Key Input Interfaces: GXA-23-PRINT, GXA-23-REZERO, GXA-23-PLUG Breeze Break: GXA-10 Large BB, GXA-17 Large BB with Ionizer GXA-25 External Ionizer, GXA-26 External IR Switch, GXA-27 Bluetooth, GXA-12 Animal Weigh Pan					
Accessories		TB247 Power Supply, AD-8127 Compact Printer, AD-1682 External Rechargeable Battery (for more accessories visit andweighing.com)					

i Under stable environment (no rapid temperature/humidity change, vibration, draft, magnetism, static, etc). The mass of the internal weight may vary with age.

ii One additional unit from tael (Singapore/HK jewelry/Taiwan/China), tola or Newton can be added upon request.

iii AN LFT models not all applications apply (excludes: statistical calculation, programmable unit, or minimum sample weight).

*GF-6001AN only NTEP certified

Dimensions (mm/inch)

Models with readability of 0.01g and 0.1g

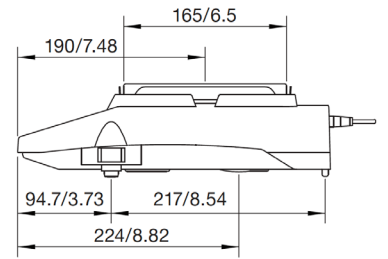
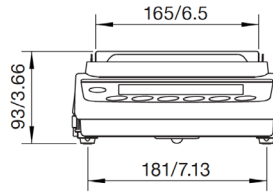
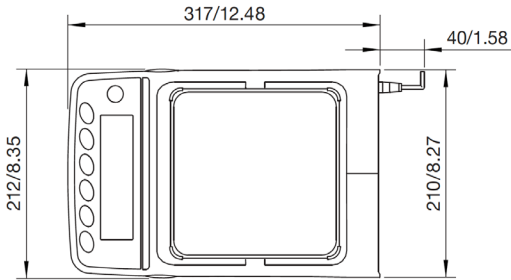

Models with readability of 0.001g

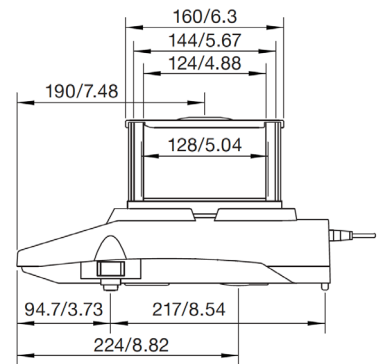
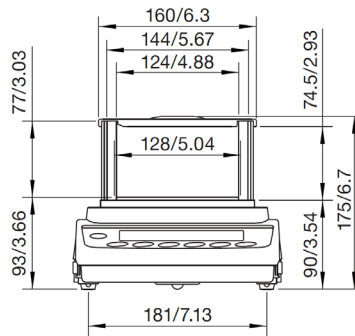
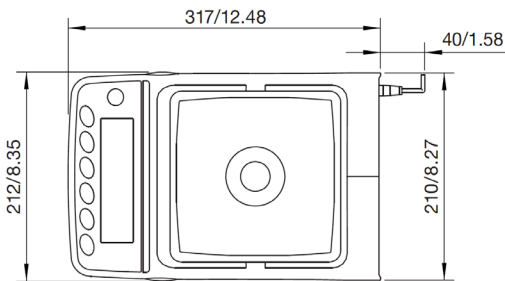

Models with readability of 0.0001g

